



Mike's "A" Ford-Able Parts

Specializing in 1928-1931 Model A Ford
Parts for Restoration and Repair



Mike's 1930 Panel Delivery - 79B



*Have An
"A"
Day*



PHONE: 706-652-3866 FAX: 706-652-2492 1-888-TRY-MIKE (879-6453)
124 Model A Drive Maysville, GA 30558 E-Mail: mike@mikes-afordable.com

Please use this catalog as a guide. Visit our website to review latest products and prices! www.mikes-afordable.com

The Fine Print

Mail Orders: You will find our order forms at the back of our "CAR SPECIFIC" Sections. Please fill the form out completely. We particularly need the year and body style of your car - body Number if known. Please make sure that you provide a complete address for your parts to be shipped to. **Couriers will not deliver to a P.O. Box.**

Telephone (706) 652-3866

Fax (706) 652-2492

Technical Advice (706) 652-3866

Orders: please use 1-888-TRY-MIKE (879-6453) In the USA Only.

Website: www.mikes-afordable.com

Email: mike@mikes-afordable.com

Payment & Prices: We will accept Checks, Money Orders, Visa, Mastercard & Discover Card. GA residents add 7% sales tax. **All orders picked up in our store will be subject to GA Sales Tax.**

ALL PRICES ARE SUBJECT TO CHANGE WITHOUT NOTICE.

Our suppliers increase their prices throughout the year. If your new price is not acceptable, please return the item for credit - Item will be subject to our Return Policy - See the Inside Back Cover.

Shipping:

We can ship via US Postal Service, UPS, Federal Express & DHL. If you would prefer to use your own UPS, FedEx or DHL accounts, please let us know when placing your order. The following chart is to be used as a **GUIDELINE ONLY** for Orders that are shipped via Courier in the USA Only. If the shipping is more, **you will be charged the couriers published rates.** **All Orders** are followed as closely as possible to the Guidelines set out below.

Amt. of Order	Surface Shipping
up to \$10.00	\$ 8.50
\$10.01 - \$15.00	\$ 9.00
\$15.01 - \$20.00	\$ 9.50
\$20.01 - \$30.00	\$10.00
\$30.01 - \$50.00	\$12.00
\$50.01 - \$100.00	\$14.00

See Inside of the Back Cover for the Continuation of "The Fine Print".

Orders over \$100.00 will usually fall into the \$14.00 range unless there are multiple boxes involved or large boxes that are then charged by the dimensional weight by the couriers. Please see the Additional Shipping Fees section for any extra fees.

International orders can be shipped by UPS, Fedex, DHL or US Mail. Rates may vary.

A Boxing & Packaging fee applies to all packages leaving our shop. The charge depends on dimensions and packing used to ensure that your order will be received safely.

Courier Additional Shipping Fees:

\$9.00 - COD's - Sorry Couriers will not accept Cash. Pay by check or money order.

\$6.50 - Additional Handling - Any item that cannot be put on a conveyor belt.

\$45.00 - Large Package Surcharge - Any package that exceeds 165" in Girth.

Parts:

Whenever possible we buy U.S.A. made parts. Quality is of utmost importance.

Backorders:

"We do our best to fill your entire order." **If an item is out of stock, you will be notified and have the choice of Mike's holding the order for you until the item is in, or ship the order and backorder the out of stock item. All backordered items will be shipped as soon as they become available. Normal shipping charges will apply.**

Very Important - PLEASE READ

Dear Model "A" er,

As it is our 15Th Anniversary catalog, we have decided to do something very different. With so many first time Model "A" restorations, we think it makes more sense to be body style specific. For Example - we will start the catalog, with parts that are common to all models - Front Fenders, Frames, Brakes, Wheels, Engine, Headlights, etc. The catalog then changes to "body style specific" - Pickups, Tudor, Fordor Sedans, Open Cars, etc.

In each of these specific sections will be every piece you will need for your restoration. In short, once you have completed your running chassis and you are building a "Roadster" you will go directly to the "Roadster / Phaeton" section and nowhere else, as everything you need will be in that section. If the piece you are looking for does not appear in that section - that piece is not remanufactured.

We hope you will enjoy our New Catalog, as we sincerely feel it will assist not only the old Pro's, but will also give all of our new younger generation a much better feel for our beloved A's/

May I at this time take this opportunity to thank all of our friends for their support over the last 15 years - and as always feel free to call us for any help you may need.

Kindest regards to all,

Mike

TABLE OF CONTENTS

INDEX

General Parts & Running Chassis Page 3-235

Body Style Identification InfoPage 236 - 237

Grandfathers Day Invitation Page 238

Commercial Vehicles -

 Including Roadster & Closed Cab Pickup P/UP 1-78

All Coupe's Coupe 1-78

Sedans (Tudor & Fordor) Fordor 1-82

Open Cars (Roadster & Phaeton) Open 1-76

Specialty Vehicles -

 Victoria, Cabriolet, 400A & Town Car Spec. 1-68



GENERAL PARTS & RUNNING CHASSIS



Mike ready to roll. When using our newly designed catalog this picture indicates as close as we can, a running chassis.

Index	Page #
Accessories & Gift Ideas	Gen. 14
Battery Parts	Gen. 91
Books & Posters	Gen. 6
Brakes	Gen. 44
Bumpers & Parts	Gen. 209
Carburetor & Parts	Gen. 150
Carburetor Controls	Gen. 156
Clutch	Gen. 128
Connecting Rods	Gen. 108
Crankshaft / Camshaft	Gen. 109
Distributor	Gen. 173
Emergency Brake	Gen. 58
Engines	Gen. 101
Fan	Gen. 145
Fender Brackets	Gen. 202
Fenders - Steel	Gen. 200
Fiberglass	Gen. 199
Floorboard & Mats	Gen. 93
Flywheel	Gen. 112
Frame & Mounting	Gen. 89
Front End Parts	Gen. 64
Generator & Alternator	Gen. 158
Grease Fittings	Gen. 31
Headlights	Gen. 183
Horn	Gen. 190
Hub Caps	Gen. 36
Hubs	Gen. 41
Ignition Switch	Gen. 169
Manifold	Gen. 146

Index	Page #
Misc. Hardware	Gen. 34
Motor Parts	Gen. 102
Moto-meter	Gen. 139
Muffler	Gen. 95
Oil Pump	Gen. 116
Pistons	Gen. 106
Piston Rings	Gen. 107
Radiator	Gen. 134
Radius	Gen. 67
Rear End Parts	Gen. 83
Restoration Supplies	Gen. 29
Running Board & Parts	Gen. 206
Shocks	Gen. 213
Sign & Magnets	Gen. 20
Spare Tire	Gen. 39
Spark Plugs	Gen. 181
Spring - Front and Rear	Gen. 98
Splash Aprons	Gen. 205
Splash Shields	Gen. 204
Starter	Gen. 164
Steering	Gen. 70
Tires	Gen. 36
Tools	Gen. 21
Transmission	Gen. 121
Upholstery	Gen. 220
Valves	Gen. 114
Water Pump	Gen. 142
Welting & Bedding	Gen. 32
Wheels & Parts	Gen. 35
Wiring	Gen. 193

Mike's "A" FORD-ABLE Parts

The 1928 Model A Fords

Body Model	Body Name	Weight Pounds	Original Price
35A	Standard Phaeton	2140	\$395
40A	Standard Roadster	2050	\$385
45A	Standard Coupe	2200	\$495
49A	Special Coupe	2200	\$500
50A	Sport Coupe	2265	\$550
54A	Business Coupe	2285	\$495
55A	Tudor Sedan	2340	\$495
60A	Fordor Sedan (Briggs)	2467	\$570
76A	Roadster Pickup	2073	\$395

The 1929 Model A Fords

Body Model	Body Name	Weight Pounds	Original Price
35A	Standard Phaeton	2140	\$440
40A	Standard Roadster	2050	\$435
45A	Standard Coupe	2200	\$500
49A	Special Coupe	2200	\$510
50A	Sport Coupe	2265	\$530
54A	Business Coupe	2225	\$490
55A	Tudor Sedan	2340	\$500
60A	Fordor Sedan (Briggs)		
	Leather Back, Seal Brown Top	2386	\$600
60B	Fordor Sedan (Briggs)		
	Leather Back, Black Top	2386	\$600
60C	Fordor Sedan (Briggs)		
	Steel Back	2386	\$600
68A	Cabriolet	2339	\$645
135A	Taxi Cab	2500	\$800
140A	Town Car	2500	\$1200
150A	Station Wagon	2482	\$
155A	Town Sedan (Murray)	2475	\$670
155B	Town Sedan (Briggs)	2475	\$670
165A	Standard Fordor Sedan (Murray - 3 Window)	2462	\$625
165B	Standard Fordor Sedan (Briggs - 3 Window)	2462	\$625
170A	Standard Fordor Sedan (2 Window)	2467	\$625

Commercial Line NOT Listed Here - For a list of 1928 - 1931 Commercial Vehicles look in "Henry's Lady" Book (A91006).

The 1930 Model A Fords

Body Model	Body Name	Weight Pounds	Original Price
35B	Standard Phaeton	2212	\$440
40B-Std	Standard Roadster	2200	\$450
40B-Dlx	Deluxe Roadster	2230	\$520
45B-Std	Standard Coupe	2257	\$495
45B-Dlx	Deluxe Coupe	2265	\$545
50B	Sport Coupe	2283	\$525
55B	Tudor Sedan	2375	\$495
68B	Cabriolet	2273	\$625
140B	Town Car	2525	\$1200
150B	Station Wagon	2505	\$640
155C	Town Sedan (Murray)	2475	\$640
155D	Town Sedan (Briggs)	2475	\$640
165C	Standard Fordor Sedan (Murray)	2500	\$600
165D	Standard Fordor Sedan (Briggs)	2500	\$600
170B-Std	Standard Fordor Sedan (Briggs)	2500	\$600
170B-Dlx	Deluxe Fordor Sedan (Briggs)	2988	\$640
180A	Deluxe Phaeton	2285	\$625
190A	Victoria Coupe	2372	\$580

The 1931 Model A Fords

Body Model	Body Name	Weight Pounds	Original Price
35B	Standard Phaeton	2212	\$435
40B-Std	Standard Roadster	2155	\$430
40B-Dlx	Deluxe Roadster	2230	\$475
45B-Std	Standard Coupe	2257	\$490
45B-Dlx	Deluxe Coupe	2265	\$525
50B	Sport Coupe	2283	\$500
55B	Tudor Sedan	2375	\$490
68B	Cabriolet	2273	\$630
68C	Cabriolet	2273	\$630
150B	Station Wagon	2505	\$625
155C	Town Sedan (Murray)	2475	\$630
155D	Town Sedan (Briggs)	2475	\$630
160A	Standard Fordor Sedan	2462	\$590
160B	Town Sedan	2475	\$630
160C	Deluxe Fordor Sedan	2488	\$630
165C	Standard Fordor Sedan (Murray)	2462	\$590
165D	Standard Fordor Sedan (Briggs)	2462	\$590
170B	Deluxe Fordor Sedan (Briggs)	2488	\$630
180A	Deluxe Phaeton	2285	\$580
190A	Victoria Coupe	2372	\$580
400A	Convertible Sedan		\$640

Mike's "A" FORD-ABLE Parts

"A" Engine Serial Numbers

Month	Numbers
October - 1927	1 - 137
November	138 - 971
December	972 - 5275
January - 1928	5276 - 17251
February	17252 - 36016
March	36017 - 67700
April	67701 - 109740
May	109741 - 165726
June	165727 - 224276
July	224277 - 295707
August	295708 - 384867
September	384868 - 473012
October	473013 - 585696
November	585697 - 697829
December	697830 - 810122
January - 1929	810123 - 983136
February	983137 - 1127171
March	1127172 - 1298827
April	1298828 - 1478647
May	1478648 - 1663401
June	1663402 - 1854831
July	1854832 - 2045422
August	2045423 - 2243920
September	2243921 - 2396932
October	2396933 - 2571781
November	2571782 - 2678140
December	2678141 - 2742695
January - 1930	2742696 - 2826649
February	2826650 - 2940776
March	2940777 - 3114465
April	3114466 - 3304703
May	3304704 - 3509306
June	3509307 - 3702547
July	3702548 - 3771362
August	3771363 - 3883888
September	3883889 - 4005973
October	4005974 - 4093995
November	4093996 - 4177733
December	4177734 - 4237500
January - 1931	4237501 - 4310300
February	4310301 - 4393627
March	4393628 - 4520831
April	4520832 - 4611921
May	4611922 - 4695999
June	4696000 - 4746730
July	4746731 - 4777282
August	-----
September	4777283 - 4824809
October	4824810 - 4826746
November	4826747 - 4830806
December - 1931	-----
January - 1932	4830807 - 4842983
February	4842984 - 4846691
March	4846692 - 4849340

Canadian Engine Numbers

PLEASE NOTE: Canadian Parts Available: **A8212CA** - Black Radiator Emblem see **Page Gen. 136** & Robertson Screw Kits see **Car Specific Sections.**

Manufacture Date

1927 (December) C.A.	1 to C.A. 5373
1928 to C.A.	73521
1929 to C.A.	150,000
September 4 to Nov 4, 1929	CAQ 1 to CAQ 10,000
Nov 18, 1929 to Feb 4, 1930	CAW1 to CAW 10,000
February 4 to March 14, 1930	CAE 1 to CAE 10,000
March 14 to April 14, 1930	CAR 1 to CAR 10,000
April 22 to May 13, 1930	CAT 1 to CAT 10,000
May 13 to June 11, 1930	CAY 1 to CAY 10,000
June 12 to August 7, 1930	CAU 1 to CAU 10,000
Aug 7 to October 16, 1930	CAI 1 to CAI 10,000
Oct. 16, 1930 to Feb 9, 1931	CAO 1 to CAO 10,000
Feb. 9, 1931 to April 1, 1931	CAP 1 to CAP 10,000
April 1 to June 2, 1931	CAS 1 to CAS 10,000
June 2, to February 22, 1932	CAD 1 to CAD 6,877

No independent record exists of the CAA numbers, but from investigations, it is believed that CAA numbers and CAAQ, CAAW etc. were taken from the numerical order, and selected for AA trucks, receiving the additional stamping to designate the heavy duty clutch needed in the assembly for use in the truck. In effect then, the numbers CA69256 (car) CAA69257 (truck) and CA69258 (car) could have followed in sequence along the assembly line.

Torque Measurements

Torque Measurements are in foot - pounds.
The following is a guide for torquing the different fasteners. Remember, if original fasteners are used, their tension loss is unknown due to the number of times they have been reused. Therefore, the torque measurement might need to be adjusted. It is recommended to use all new fasteners. See "Nuts and Bolts" article in How to Restore you Model A, Volume 3.

Main Bearing Cap Bolts	70 - 80
Camshaft Nut	100
Connecting Rods	45
Head	50

Torque up in three stages using correct sequence with final torque after engine is hot.

Water neck - Torque with caution	50
Manifold - Exhaust	55
Timing Cover	25
Water Inlet	40
Pressure Plate - Use Grade 5 Bolts	25
Axle housing to differential	35
Torque tube to Differential	35
Oil Pan	15 - 25
Valve Cover	15 - 25
Flywheel	55
Rear Axle Shaft Nut	125

Mike's "A" FORD-ABLE Parts

BOOKS & POSTERS

PLEASE NOTE:

Books are NOT Refundable!

Henry's Lady

320 Pages. This book features over 1000 close up pictures of restored cars. Written by Ray Miller.

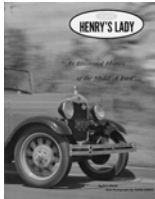

A91006 28-31 Price Ea. \$ 56.00

Model "A" as Henry Built It

232 Pages. Many original Ford Photos and information on how the "A" was built. Written by George De'Angelis, Ed Francis and Les Henry.



A91008 28-31 Price Ea. \$ 36.95

The Legendary Model "A" Ford

272 Pages of Model "A" History. This beautiful coffee table book is full of color Pictures, Stories and Technical Information. A great gift book for that special someone who has everything!! 2nd Edition - All Color.

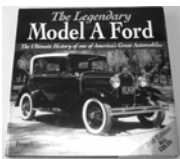

A91025 28-31 Price Ea. \$ 34.95

The Ford Century

272 Pages. Hard bound. The hundredth Anniversary book is a fascinating highly visual look into the history of an American Icon - a company with a household name that has been a part of the fabric of our nations history. Ford's story is one of inventions, personalities, legendary vehicles, setbacks, and successes. A dedication to ford Motor company and the innovations that shaped the world.

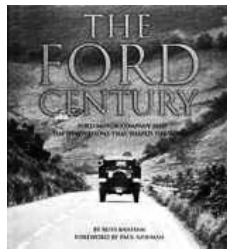

A91071 Price Ea. \$ 40.00

The Original Ford Model A

128 Pages. The Restorers Guide - for original factory specifications and model evolution. Specifications included for each model and Year. Over 250 color photos of body work, interiors and mechanical details.

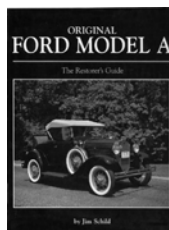

A91067 Price Ea. \$ 34.95

The Cars that Henry Ford Built

A commemorative tribute to Fords most remembered automobiles up to 1941. 136 Pages.

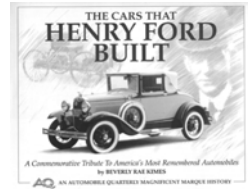

A91079 28-31 Price Ea. \$ 19.95

Model "A" Ford Mechanics Handbook - Vol. I

The most complete book we have, detailed mechanical and maintenance articles. Over 500 Illustrations. "A" must have book. By Les Andrews.

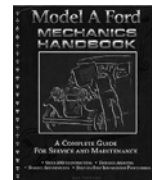

A91024 28-31 Price Ea. \$ 36.00

Model "A" Ford Mechanics Handbook - Vol. II

300 Pages. If you liked Vol. 1 and admit it, who didn't, then you will love volume II of the ever popular Mechanics Handbook. This latest edition describes the installation of aftermarket products in addition to a complete section of increasing Speed and Power for touring today's highways. Written by Les Andrews.

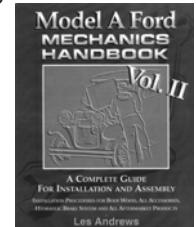

A91029 28-31 Price Ea. \$ 30.00

Trouble Shooting and Diagnostics

200 Pages. A wonderful accompaniment to The Mechanics Handbook. This detailed book will help with those little rattles, rumbles or groans that need a little tweak. Five Sections including tests to perform on the road, and also in the shop. What's making that awful noise?? Look it up in Section 3. How does that thing work?? All of the Major Operating systems are explained in Section 4. Section 5 details all of the special equipment needed to test and tune your Model "A". By Les Andrews.

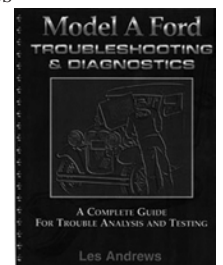

A91028 28-31 Price Ea. \$ 29.50

Practical Information about 1930-1931 Coupes "A to Z"

175 Pages. A great "How to Book" for Coupe owners. Featuring many detailed articles and pictures of individual parts.

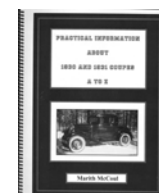

A91022 30-31 Price Ea. \$ 34.00

BOOKS & POSTERS

Gen.6 Give us a call - 1-888-TRY-MIKE (879-6453) Have an "A" Day!

Mike's "A" FORD-ABLE Parts

Selling the new Ford

180 Pages. "One of the greatest advertising programs in the history of modern business." Tells how Henry Ford made the Model A front-page news. Photos of rare prototype Model A body styles. A must for everyone interested in the Ford Model A. Reprints of 115 ads and photos / hundreds of illustrations.



A91053 27-31 Price Ea. \$ 24.00

Judging Standards

Very informative book published jointly by the Model A Ford Clubs. All of the information that you will need if you plan on showing your car. 1998 updates are included. Parts changes are listed by month and year. Comes with a 3 ring binder.



A91033 28-31 Price Ea. \$ 36.00

Judging Standards for Open Cars (Touring)

If you are building an Open car and want to make sure that you have everything correct for competition this is the book that you will need.



A91078 Price Ea. \$ 8.25

Original Model A Ford Service Bulletins

Limited edition reproduction of Ford Motor Company's Service Bulletins as supplied to its dealers. Three ring binder embossed and printed similar to the original.

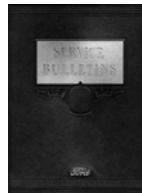

A91000 28-31 Price Ea. \$ 39.95

Model A Ford Service Bulletins

319 Pages. Hardbound Book version of A91000, but without the beauty of the original. - Dealers received an update every month on new items and changes made to the "A".



A91001 28-31 Price Ea. \$ 30.00

Model A Ford Service Bulletins - Paperback

This is the same book as A91001, but comes in paperback with the original size print on 8 1/2 x 11 paper.



A91001A 28-31 Price Ea. \$ 21.50

Service / Branch Letters

Copies of original documents from Ford to the dealers.



A91088



A91086

A91089

Indianapolis, IN

Fargo, ND

Chicago, IL

Price Ea. \$ 19.95

Price Ea. \$ 19.95

Price Ea. \$ 19.95

MARC Complete Fashion Guidelines

The complete collection of Fashion Guidelines. You will get both sets A91080A & A91080B. Order A91080 for complete set.



A91080 Price Set \$ 32.50

MARC Fashion Events Guidelines & Women's Footwear and Accessories

The Events Guidelines and Footwear books are sold together. Outlines national fashion events for chairpersons, and entrants and includes information on shoes, hosiery and accessories for all four Model "A" years.



Order A91080 for complete set.

A91080A Accessories Addition Only Price Pair \$ 20.00

Women's Active Sports & Women's Wedding Apparel

Information on Sportswear, beach wear, and spectator sportswear and Information on wedding apparel for the bride and wedding party. Order A91080 for complete set.



A91080B Sport & Wedding Apparel Addition Price Pair \$ 15.00

Fashion Guidelines

Complete selection of Women's, Children's & Mens Fashion Guidelines. Comes with soft cover binder and 1994 Revisions.



A91081 Price Set \$ 30.00

Updates to Fashion Guidelines (A91081).

A91081A Women's Price Set \$ 14.00

A91081B Children's Price Set \$ 10.00

A91081C Men Price Set \$ 10.00

A91081D 1996 Update to Fashion Guidelines Price Set \$ 4.00

BOOKS & POSTERS

Order online at www.mikes-afordable.com and get a 5% Discount.

Gen.7

Mike's "A" FORD-ABLE Parts

How to Restore Your Model "A"

Reprint of articles featured in the Model A Ford Club of America Magazines.

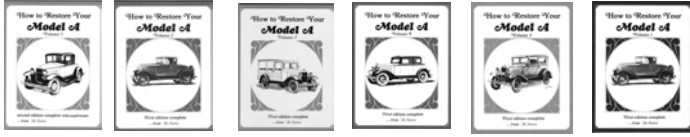

A91004	Vol. 1		Price Ea.	\$ 14.00
A91005	Vol. 2		Price Ea.	\$ 14.00
A91014	Vol. 3		Price Ea.	\$ 14.00
A91021	Vol. 4		Price Ea.	\$ 14.00
A91023	Vol. 5		Price Ea.	\$ 14.00
A91026	Vol. 6		Price Ea.	\$ 14.00
A91035	Vol. 7		Price Ea.	\$ 14.00
A91000A	Set of 7		Price Set	\$ 98.00

Technically Speaking Books

A new series of Books - released by "The Model A Restorers Club". Each volume will include all the original technical articles written within a time period. Approx. 120 pages. A new volume will be released each year.



A91076	Vol. 1 - 1965 into 1967	Price Ea.	\$ 12.50
A91077	Vol. 2 - 1968 into 1971	Price Ea.	\$ 12.50
A91085	Vol. 3 - 1971 into 1975	Price Ea.	\$ 12.50
A91036	Vol. 4 - 1976 into 1979	Price Ea.	\$ 12.50
A91047	Vol. 5 - 1980 into 1983	Price Ea.	\$ 12.50
A91013	Set of 5	Price Set	\$ 58.00

Instruction Book

This book gives basic operating instructions on timing, greasing, etc. Model A's came with an owners manual, this is a reprint of the book printed from 1928 to 1931.

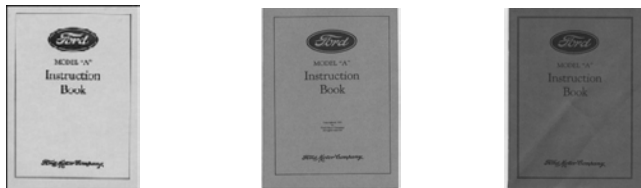

A91003A	1928	Price Ea.	\$ 14.00
A91003C	1929	Price Ea.	\$ 14.00
A91003D	1930	Price Ea.	\$ 14.00



If you have a 1931 with an indented firewall, this book is for you.

A91003B	Late 1931	Price Ea.	\$ 14.00
---------	-----------	-----------	----------

Model A Era Ford Dealer & Service Field Magazine

A complete reproduction in size and color of the original magazine. This first edition is Volume 29 Issue 1 dated January 1928. Further issues to follow. Loaded with articles on the "new" Ford being introduced.



A91020	Jan. '28 - Dec. '28	Price Ea.	\$
--------	---------------------	-----------	----

Restoring the Open "A"s

72 Page. Roadster and Phaetons 28-31. This book has a number of original pictures of Roadsters and Phaetons.



A91011	28-31	Price Ea.	\$ 25.5
--------	-------	-----------	---------

Model A Shop Manual

223 Pages. A complete and accurate, well illustrated restoration and maintenance guide. Detailed photos and drawings, easy to follow chapters..

Restorer's Model A Shop Manual



A91018	28-31	Price Ea.	\$ 40.00
--------	-------	-----------	----------

AA Truck - Supplement to Restorer's Model A Shop Manual

92 Pages. A great restoration guide for your AA Truck. Written by Jim Schild.

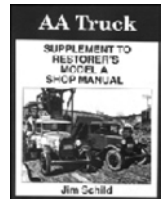

A91009B	28-31	Price Ea.	\$ 24.00
---------	-------	-----------	----------

Model A & AA Ford Truck Owner

288 Pages. A Hard bound book covers field uses, body types, accessories, capacities, original prices and specs. Adapted from Truck Fax: The Ford Truck in Trade and commerce, and exhaustive 1930 documentation for dealers, product presentation & non-factory equipment offerings. 500 Illustrations.

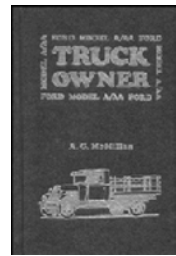

A91002	28-31	Price Ea.	\$ 26.00
--------	-------	-----------	----------

Restoring the Model "A" Pickup

50 Pages. 80 Pictures. This book shows many beautiful photos of restored Pickup's in different locations.



A91009A	28-31	Price Ea.	\$ 30.50
---------	-------	-----------	----------

BOOKS & POSTERS

Gen.8 Give us a call - 1-888-TRY-MIKE (879-6453) Have an "A" Day!

Mike's "A" FORD-ABLE Parts

Model A Construction, Operation and Repair

532 Pages. Many detailed repair operations are featured in this book. Written in 1930.



A91016 28-31 Price Ea. \$ 34.00

Model "A" Ford Restoration and Maintenance Handbook - Volume 1.

58 Pages. The comprehensive book covers many subjects, including: inspection, starter, distributor, vacuum, gauge, battery, amp meter, carburetor, brakes, front spindles, and water pump by Paul Moller.



A91012 Price Ea. \$ 14.00

Model "A" Ford Restoration and Maintenance Handbook - Volume 2.

Continuation of Volume 1 - discussing the rebuilding of the following: amp meter, cutout, powerhouse generator, carburetor fuel lever, rebuilding steering (2 Tooth & 7 Tooth), Transmission changes and repairs and Model "B" Carburetors.



A91017 Price Ea. \$ 14.00

Model "A" Miseries and Cures

229 Pages. This book contains many answers to common problems that can occur on a Model A. Answers to hot amp meter, squeaking brakes, carburetor problems, clutch chatter, testing coil, etc. By Mary Moline.

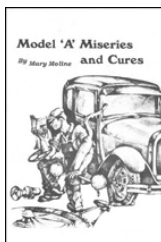

A91031 28-31 Price Ea. \$ 28.00

The Model "A" Ford Q & A Workshop Manual

Straightforward answers to over 125 of the most asked and debated restoration and maintenance questions. The Who, what, where, when and why of the Model "A" Ford. "A" must for every Model "A" enthusiast's collection. By Fred Serfass.

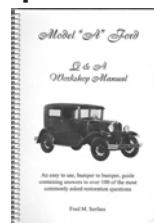

A91032 28-31 Price Ea. \$ 13.00

Model A Ford Paint and Finish Guide

This book contains the original color chips along with the correct color combination charts for your Model A.



A91010B 28-31 Price Ea. \$ 24.95

Antique Ford Repaint Manual

16 pages plus paint chart. 50 Authentic color chips and color schemes with paint preparation information / includes a refinishing detail chart, refinishing schedules, and factory production schedules / 55 illustrations / 30 photographs.



A91052 28-36 Price Ea. \$ 28.00

K. R. Wilson Book

100 Pages. Reprint of 1931 catalog of all the Model A Tools and how they were used.



A91019 29-31 Price Ea. \$ 28.00

Thunder Road Electrical Guide

A guide for Rods & Customs, Antiques & Racing Vehicles. Six to twelve volt Conversions. Including information on Fuse Panels, Relays, Solenoids, Switches, Overdrives, Steering Columns, Gauges, Ignitions, Power Windows and Seats.

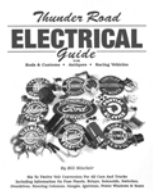

A91015 All Price Ea. \$ 26.00

Model A Carburetor

58 Pages. Illustrated, restoration book for Zenith Carburetors and a 15 pages section on Tillotson Carburetors. Written by Paul Moller.



A91007A 28-31 Price Ea. \$ 14.00

Carburetor Restoration Guidelines

37 Pages. A very helpful book on jets, (how they affect performance, flow of gas through jets, etc.). Also featuring the changes in production thru the years.



A91007B 28-31 Price Ea. \$ 15.40

The Model "A" Generator & Starter

This book describes the Model "A" Generator and also has special sections on the Model "A" Starter, Cutout & Starter Switch. By Paul & William McCree.



A91027 Price Ea. \$ 17.50

Model "A" Engine, Distributor & Oil Pump

110 Pages. A wonderful "How to" Book on engine rebuilding for your Model A. Every component is mentioned as well as assembly and disassembly. Over 100 Pictures and drawings. Written by William & Paul Mcree.



A91037 28-31 Price Ea. \$ 19.50

BOOKS & POSTERS

Order online at www.mikes-afordable.com and get a 5% Discount.

Gen.9

Mike's "A" FORD-ABLE Parts

Ford Model "A" Standard Hardware 1928 - 1931

Get the all the information on the Hardware that you car originally came out with.



A91030 28-31 Price Ea. \$ 10.00

Automotive Hardware and Trimming Supplies

Illustrated with Pictures and dimensions of trim parts.



A91034 28-38 Price Ea. \$ 24.00

Steering Wheel Restoration Handbook

23 Pages. A wealth of unique information never before revealed. Tips on restoring your aging steering wheel. 83 black and white photos.



A91074 Price Ea. \$ 11.50

Know your Model "A" Ford / The Gem from River Rouge

A hard bound detailed book discussing nontechnical principles on operation and history of the Model A. 42 Chapters cover the motor, electrical system and the rear end. 175 Illustrations.



A91038 28-31 Price Ea. \$ 22.00

Matchless Model "A" / Tour of Ford Industries

64 Pages. This is a reprint of a book published by the Ford Motor Company, and is a history of Ford during the Model A era. Offers an overview of the amazing methods which made motor car history, from iron ore to driveway. 150 Photographs.

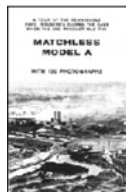

A91039 28-31 Price Ea. \$ 14.00

Those Wonderful Unauthorized Accessories for Model A Ford

256 Pages. Independent accessory manufacturers produced a veritable galaxy of special items for the Model A. A parade of bona fide extras from the original promotional material. 450 Illustrations. Hard bound.



A91040 28-31 Price Ea. \$ 22.00

Model A Restoration Manual

72 Pages. A super reference book with basic information for all years, contains many diagrams and details, includes paint colors, body dimensions, motor numbers and specifications. 29 Illustrations, with many photographs.

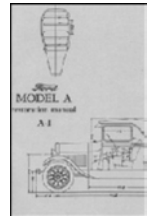

A91041 28-31 Price Ea. \$ 12.00

Model A Chassis Parts Book

120 Pages. Covers engine and chassis for Model A-AA and V8 with correct name and Ford part number / also covers the complete hardware used for attaching each part / with a listing of body types and finishes of standard cars. 29 Illustrations.



A91042 28-31 Price Ea. \$ 16.00

Model A Body Parts List

246 Pages. A complete listing of cars and trucks, covers body parts exclusively, with information on what years and body styles they fit and interchange with, indexed by body styles with many body photographs. 50 illustrations.



A91043 28-31 Price Ea. \$ 26.00

Model A and AA Engine Chassis Manual

40 Pages. Covers Model A and AA trucks / a reprint of a Dykes supplement which includes specifications and operating instructions, contains wiring diagrams and lubrication charts / 64 illustrations.



A91044 28-31 Price Ea. \$ 14.00

Shop Kinks and Tools

45 Pages. A pocket sized book of minor repair instructions, and the tools used in the repair of fords. Covers Models A, B and V8, includes a troubleshooting section and electrical hints. 84 illustrations.



A91045 30-33 Price Ea. \$ 5.00

Improved Features of the New Ford

18 Pages. Good general information that covers all new features and body styles for the new 1930 - 1931 Model A. 12 Photographs.



A91046 30-31 Price Ea. \$ 4.00

Henry's Fabulous Model A Ford

111 Pages. A gold mine of Model A information contains restoration hints and historical details on the birth and evolution of the Model A. Includes a color equivalent paint list, and listing of parts suppliers and sources. 96 photographs & 20 illustrations.



A91048 28-31 Price Ea. \$ 33.00

BOOKS & POSTERS

Gen.10 Give us a call - 1-888-TRY-MIKE (879-6453) Have an "A" Day!

Mike's "A" FORD-ABLE Parts

Ford Model A Album

143 Pages. A pictorial history of the Model A, includes trucks and accessory information. Contains many reproductions of original ads, a motor list, and a listing of prominent general characteristics of each style & year. 50 photographs.



A91049 28-31 Price Ea. \$ 24.00

How to Restore a Model A Ford

218 Pages. A compilation of materials and information. A basic book for ground up restoration, includes listings of parts suppliers and sources as well as book suppliers. Contains original price lists, 67 photographs & 119 illustrations and charts.



A91050 28-31 Price Ea. \$ 24.00

Model A Ford Restoration Handbook

189 Pages. A good beginner's book, complete specifications, color charts, wiring diagrams, and other data. Includes color equivalent charts and a breakdown of color combinations by year and body style. 42 photographs & 64 illustrations.



A91051 28-31 Price Ea. \$ 24.00

The New Ford Truck

12 page sales booklet in 2 colors. Features all truck and commercial cars, plus specifications, illustrated.



A91054 28-31 Price Ea. \$ 5.00

The Deluxe Body Types

12 page sales booklet in 2 colors. Features all deluxe passenger models and specifications / illustrated.



A91055 30-31 Price Ea. \$ 5.00

The Standard Body Types Adding New Beauty to Outstanding Performance

12 page sales booklet in 2 colors. Features all standard passenger models and specifications / illustrated.



A91056 30-31 Price Ea. \$ 5.00

Features of the Ford Car

12 page sales booklet in 2 colors. Information booklet that explains new features and differences between Standard and Deluxe.



A91057 28-31 Price Ea. \$ 4.00

The Story of the New Ford Car

14 page sales booklet in full color. Shows body styles and information on color, equipment, etc. / illustrated.



A91058 28-29 Price Ea. \$ 6.00

The New Ford

14 page sales fold out in color. Shows all body styles and information on new models / illustrated.

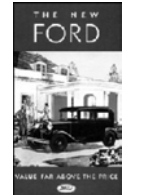

A91059 30-31 Price Ea. \$ 5.00

Model A Accessory Brochure

2 color fold-out pages with photographs. Presents all the Ford Model A authorized accessories for 1930 - 1931.



A91060 30-31 Price Ea. \$ 5.00

Ford Battery Information Brochure

3 page fold out. Information folder, in 2 colors, on the Ford Battery for the Model .

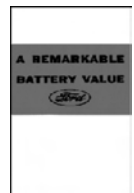

A91061 28-31 Price Ea. \$ 4.00

Rustless Steel

4 pages. Information folder on "Rustless Steel" used on the '30-'31 models. Illustrated, 2 colors.



A91062 30-31 Price Ea. \$ 5.00

Ford Manufacturing Methods

8 pages. Information on how Ford is able to save the consumer money because of manufacturing methods. 2 Colors.



A91063 28-31 Price Ea. \$ 4.00

"Grandpa, Tell Me About The Model A!"

By Former MAFCA President, Jack V. Crawford. A Coloring book for the grandchildren. Get them started early.

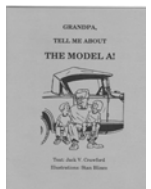

A91083 Price Ea. \$ 4.00

BOOKS & POSTERS

Order online at www.mikes-afordable.com and get a 5% Discount.

Gen.11

Mike's "A" FORD-ABLE Parts

Model "A" Ford Advertisements Poster Book

A book of eight beautiful 11 x 14 full color advertisements of the Ford automobile plus a portrait of Henry Ford. Each ad printed on one side only, suitable for framing.



A91084 Price Ea. \$ 15.50

America's First Fun Car Poster

Great Multicolored poster that shows the most popular models of the famous Model A Fords. A great display item for the Ford enthusiast. 29" x 22".



A91064 28-31 Price Ea. \$ 6.00

Henry's Lady Poster

Full color poster. 23" x 36" high gloss poster stock. Suitable for framing, shows many models and years.



A91065 28-31 Price Ea. \$ 7.00

Fabulous Fords Poster

Full Color poster of 69 Ford factory photos from 1896 to 1940. 29 Are original Ford prints of Model "A" Fords. 24" x 36" Poster.



A91068 28-31 Price Ea. \$ 5.95

Model A Ford Car Poster

This poster features a story about Henry Ford himself. Also includes 40 Model A factory pictures. The poster is 24" x 36".



A91069 28-31 Price Ea. \$ 5.95

New Ford Poster

Chances are, that you would have found this poster hanging on the wall of your local Model A Dealer's showroom. Describes the special features of the Model A Ford. This is a 17" x 36" color poster.

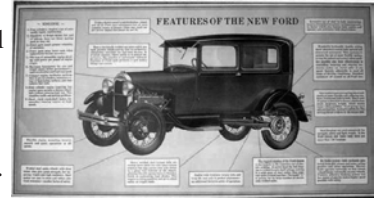

A91070 28-31 Price Ea. \$ 10.00

"Ford Model A Power Plant Troubles Made Easy" Poster

A Quality reprint of the original 1928 chart. Outlines engine parts, fuel systems, ignition group, and cooling system, problems that are liable to make an engine lose power, start hard or work irregularly and simplifies location of engine faults. Original size, color and paper stock. 22" x 34".

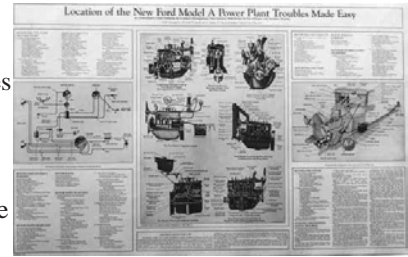

A91087 28-31 Price Ea. \$ 12.95

75th Anniversary Poster

Commemorative Model "A" Poster. 25" x 20"



A91082 Price Ea. \$ 15.00

Lube Chart

Use this chart to make sure that you are lubing all of the essential places. Full color Poster - ready to be framed - 17" x 22".

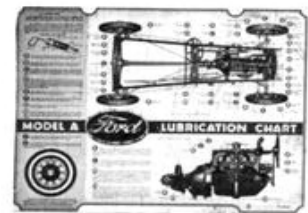

A91072 28-31 Price Ea. \$ 5.00

Wiring Diagrams

Made in the USA. If you need to do any rewiring, don't take a chance on doing it wrong. These are color-coded and good for all years.



A14350A 28-31 With cowl lights Price Ea. \$ 8.00

A14350B 28-31 Without cowl lights Price Ea. \$ 8.00

Mike's "A" FORD-ABLE Parts

Ford Color Prints

Beautiful prints of Made in America cars. Full color prints are from original paintings by Ford Motor Company illustrator Don Pacitti. You can order these prints with or without the Wood Grain finished frame with gold highlights.



Prints ONLY - 11" x 14"

A91340A	28-29	Standard Roadster - 40A	
A91360	1929	Fordor Briggs Sedan - 60A	
A91140	28-29	Deluxe Town Car - 140A	
A91180	30-31	Deluxe Tudor Phaeton - 180A	
		Price Ea.	\$ 3.00



Prints ONLY - 12" x 18"

A91335A	1928	Phaeton - 35A	
A91335B	1930	Standard Phaeton - 35B with Deluxe features	
A91340B	1930	Deluxe Roadster - 40B with Windshield folded	
A91354	1928	Business Coupe - 54A	
A91368A	1929	Cabriolet - 68A	
A91368C	1931	Cabriolet - 68C	
A91155	1929	Town Sedan - 155A	
A91400	1931	Convertible Sedan - A400	
		Price Ea.	\$ 4.00

Framed Prints

You can order these prints with or without the Wood Grain finished frame with gold highlights.



Framed Prints - 11" x 14"

A91340AF	28-29	Standard Roadster - 40A	
A91360F	1929	Fordor Briggs Sedan - 60A	
A91140F	28-29	Deluxe Town Car - 140A	
A91180F	30-31	Deluxe Tudor Phaeton - 180A	
		Price Ea.	\$ 18.00

Framed Prints - 12" x 18"

A91335AF	1928	Phaeton - 35A	
A91335BF	1930	Standard Phaeton - 35B with Deluxe features	
A91340BF	1930	Deluxe Roadster - 40B with Windshield folded	
A91354F	1928	Business Coupe - 54A	
A91368AF	1929	Cabriolet - 68A	
A91368CF	1931	Cabriolet - 68C	
A91155F	1929	Town Sedan - 155A	
A91400F	1931	Convertible Sedan - A400	
		Price Ea.	\$ 18.00

Ford Garage Nostalgic Photo

8" x 10" Black and White Print
Not framed.



A91305	Price Ea.	\$ 6.00
--------	-----------	---------

Ford Dealer / Gilmore Station Nostalgic Photo

8.5" x 11" Black and White Print.
Not framed



A91310	Price Ea.	\$ 6.00
--------	-----------	---------

ACCESSORIES & GIFT IDEAS

Pedal Pads

Ever had your foot slip off of one that's gotten too smooth? These rubber pads fit over the brake and clutch pedals. Red for the earlier cars.



A18422R Red - 1928 **Price Pair** \$ 9.95
A18422 28-31 **Price Pair** \$ 3.95

Fulton Pedal Pads

This is a copy of the original rubber pedal pads. Pads are held on by stainless trim.



A18422F 28-31 **Price Pair** \$ 33.00

Fulton Accelerator Pedal

This is an exact copy of a popular accessory used with this accelerator by bolting onto the floorboard. Chrome pedal with rubber insert.



A9735F 28-31 **Price Ea.** \$ 30.50

Sparky Start

This handy gadget attaches to your starter using the same mounting holes as your starter switch. When you retard your spark lever on the steering column, it automatically engages the starter switch to start the car. The starter button on the floor is still usable.



A11460 28-31 **Price Set** \$ 39.95

Hand Starter

This accessory mounts to your steering column and allows you to apply the starter button with a rod. You can still use your foot activated rod with this unit.



A11470F 28-31 **Price Set** \$ 64.95

Handle Extension

An extension that attaches to the **A2780C** Emergency Brake Lever, and makes the releasing of the handle easier. A duplication of an original accessory.



A2780EXT July '29 - End **Price Ea.** \$ 64.95

Rear Main Janitor - Diaper

A diaper for your Model A!! Catch that pesky oil that leaks onto your garage floor out of the rear main seal with this black powder coated unit. Simply slips over the lower bell housing to flywheel housing bolts and one of the flywheel dust cover bolts. Goes on and off in seconds for a quick cleanup.



A6768 28-31 **Price Ea.** \$ 19.95

Dipstick Wiper

A copy of an original accessory that was made by APCO. This stainless steel unit mounts under the head nut above the water inlet on the side of the block. Simply drag your dipstick thru the felt for easy cleanup.



A6751 28-31 **Price Ea.** \$ 24.95

Seat Belt Sets

Do you want to take the grand kids for a ride?? Don't forget to buckle up. Very quickly becoming a necessity in today's fast pace traffic. For installation instructions, please see "How to Restore your Model "A", Vol 6 - **A91026** or Vol. 2 of "Model A Ford, Mechanics Handbook" - **A91029**. **New and Improved** - Our belts have a special L shaped bracket to make installation easier. All hardware is included.

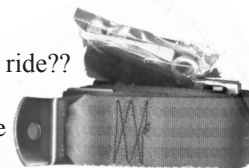

A26650 Brown **Price Ea.** \$ 18.95
A26660 Green **Price Ea.** \$ 18.95
A26670 Black **Price Ea.** \$ 18.95
A26680 Gray **Price Ea.** \$ 18.95
A26690 Tan **Price Ea.** \$ 18.95

Waffle Style Manifold Heater (Autolite)

This aluminum heater has two mounting holes that are 7 1/16" apart from center of holes. Heater door valve is not included.

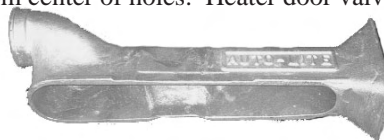

A18478WS 28-31 **Price Ea.** \$ 79.95

Manifold Heater (Aluminum)

This takes the chill off a morning. It bolts onto the manifold with no cutting or welding and has a firewall valve to control the heat, includes extra clamps for fitting the manifold heater. **The valve A18479S is included.**



A18478S 28-31 **Price Set** \$ 72.50

Manifold Heater Valve Door

Replacement firewall valve only. It mounts directly on the firewall to let you control the heat coming through. Needs a 2" hole cut into the firewall. **This is included with A18478S.**



(Extra Clamps are NOT included for fitting to the manifold.)
A18479S 28-31 **Price Set** \$ 10.50

Mike's "A" FORD-ABLE Parts

Manifold Heater Door Patch Panel

4 1/2 x 8" panel fills the area where the heater hole was usually cut. Original gauge steel, with the exact contour reinforced ribs.

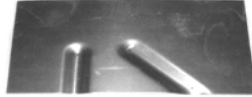

A18478P 1930 - May 31 Price Ea. \$ 12.95

Heaters

Do you get cold when you drive your car in the winter? Now there is a solution to keep you warm, so you can drive your car, year round. This universal aftermarket heater, uses the coolant system for its heat. You will have to run hoses to this unit from your motor. Don't forget to order A18480K Hose and fitting set - You may also need A8274 Heater Hook-Up Kit.

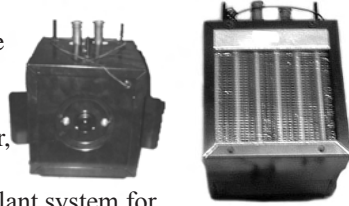

A18480-6 6 Volt Price Ea. \$ 160.00
 A18480-12 12 Volt Price Ea. \$ 133.50

Heater Hose and Fitting Set

When installing the A18480-6 or 12 heater, you will need to install this kit. Kit includes 8' of 3/4" ID hose, an elbow shut off valve that has a 3/8" pipe thread on one side, and a 3/4" hose barb on the other, a 3/8" to 1/2" OD pipe adapter and 4 hose clamps. See A8274 for Heater Hook-up Kit.



A18480K 28-31 Price Set \$ 27.00

Heater Hook-Up Kit

Make your life a little simpler with the easy installation of a hot water heater in your Model "A". Replace your lower water pipe with the long pipe. Has a nipple for the original petcock as well as a nipple for the return hose with the fitting. The shorter pipe splices into your upper radiator hose and has a nipple for the temperature gauge as well as the water pickup connection. Pipes are all powder coated black and include clamps for the upper pipe. Upper fitting has a special scooped inlet to force water into the heater.



A8274 28-31 Price Ea. \$ 49.95

Water Inlet

Use this aluminum inlet with an extra boss for heater hookup. Comes with plug and bolt for wire clip. Use this Inlet with the 6 or 12 Volt Heater (A18480-6 or A18480-12) and the Heater Hook up Kit (A8274).



A8275ACC 28-34 Price Ea. \$ 59.95

Brookland Windshields

Give your Speedster that antique look by adding on a pair of Brookland's. Sold individually and all brackets are included.



A37100 28-31 Price Ea. \$ 210.00

Transmission Walnut Shift Knob

Classy dark walnut with the Ford logo on the head. 5/16 - 24 Thread.



A7213W 28-31 Price Ea. \$ 17.10

Glass Shifter Knobs

Available in 4 different colors! An Aftermarket accessory. Insert has a 5/16" thread but can be removed, drilled and tapped for larger sizes.



Round

A7213BO Blue & White
 A7213GO Green & White
 A7213KO Mauve & White
 A7213RO Red / Orange & White

Price Ea. \$ 17.50

Mushroom

A7213BOM Blue & White
 A7213GOM Green & White
 A7213KOM Mauve & White
 A7213ROM Red / Orange & White

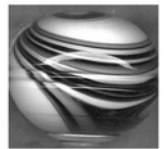

Price Ea. \$ 17.50

Clock Shift Knob

A wonderful gift idea. Available in a black mushroom or a round wooden gear shift knob with a quartz clock inserted into the center. The threads are 5/16-24. The round wooden knob will vary due to the nature of the wood.

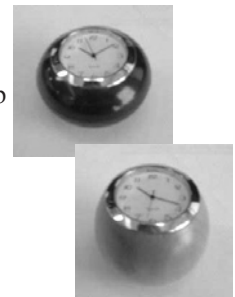

A7213CB Black Mushroom Price Ea. \$ 25.95

A7213CW Round Wood Price Ea. \$ 25.95

ACCESSORIES & GIFTS

Order online at www.mikes-afordable.com and get a 5% Discount !!

Gen.15

Mike's "A" FORD-ABLE Parts

Clock Mirrors

Mirror clocks are designed especially for the Model A Fords. Two of the outstanding features found in each Clock Mirror are the beautiful beveled quality mirror along with the accurate and dependable Quartz timepiece with its Arabic or Roman Numeral dial reflecting styles of the past. Comes with a 2 year manufacturer warranty. Please make sure that your bracket will adjust to hold a 2" high mirror. Shown on a bracket - this is NOT included.



A17705AS	Silver Arabic		
A17705AG	Gold Arabic		
A17705RS	Silver Roman Numeral		
A17705RG	Gold Roman Numeral		
		Price Ea.	\$ 95.00

Clock Mirror with Polished Edge

A beautiful replacement clock mirror with a polished edge. The mirror is not glass.



A17706	28-31	Price Ea.	\$ 39.95
---------------	--------------	------------------	-----------------

Traffic Light Finder

This was a popular accessory to avoid a stiff neck trying to see traffic lights. This prism sticks on the windshield with a suction cup. Plastic - does not chip.



A18300	ANY	Price Ea.	\$ 15.25
---------------	------------	------------------	-----------------

Flag Set

This bracket is designed to mount between the radiator motometer and the locking cap. Can be modified to fit elsewhere. 5 Flags and Bracket.

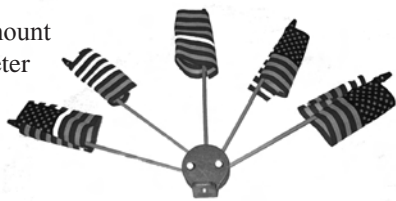

TA8019	28-31	Price Set	\$ 21.50
---------------	--------------	------------------	-----------------

Flag Set

A new design Stainless Steel bracket that holds 3 flags and is held in place by the locking cap of your motometer or flying / thermo gauges. Can be installed and removed very quickly. Includes 3 flags.



A18502	28-31	Price Set	\$ 26.50
---------------	--------------	------------------	-----------------

Flag Set

This bracket slips under the hood panels and sits between them and the radiator shell. 3 Flags and Bracket.



TA18501	28-31	Price Set	\$ 8.00
----------------	--------------	------------------	----------------

Flag Set

This is a special bracket designed to replace the bumper clamp backing plate so you can show your colors. Set includes 2 flags.



A17756F	28-31	Price Set	\$ 29.95
----------------	--------------	------------------	-----------------

Flag Set

New Design. Spring Loaded Bumper Flag Set. The spring hooks over the bumper. The flag will fit into the holder on the side of the spring. Great idea if you don't want to take your backing plates off. One Flag and holder per set.



A18500B	28-31	Price Set	\$ 34.50
----------------	--------------	------------------	-----------------

Tire Bands

Finally back in stock!! These are a reproduction of an original accessory. No hardware needed, these just snap around the tire and stay put.



Fits both 19" & 21".

Polished stainless.

These do require additional shipping due to the oversized box.

A18600	28-31	Price Ea.	\$ 175.00
---------------	--------------	------------------	------------------

Tire Band Face Plate

These steel face plates must be used with the above Tire Bands (A18605). Place the Face Plate onto the side wall of the tire and then attach the Tire Band. These are to be painted



Available for 19" tires - 30-31 Only. These do require additional shipping due to the oversized box.

A18615	30-31	19"	Price Ea.	\$ 76.50
---------------	--------------	------------	------------------	-----------------

Beauty Rings

These bands attach onto your wheels. They are high quality stainless steel rings. Installation Instructions Included.



A18021A	28-29	1, 2 or 3	Price Ea.	\$ 91.00
----------------	--------------	------------------	------------------	-----------------

A18021		Sets of 4, 5 or 6	Price Ea.	\$ 88.50
---------------	--	--------------------------	------------------	-----------------

A18019A	30-31	1, 2 or 3	Price Ea.	\$ 86.00
----------------	--------------	------------------	------------------	-----------------

A18019		Sets of 4, 5 or 6	Price Ea.	\$ 84.50
---------------	--	--------------------------	------------------	-----------------

ACCESSORIES & GIFTS

Gen.16 Give us a call - 1-888-TRY-MIKE (879-6453) **Have an "A" Day!**

Mike's "A" FORD-ABLE Parts

Spoke Covers

Comes with complete instructions. A long awaited old accessory brought back to finish the look of your Model "A" Wheel. One set does one wheel.

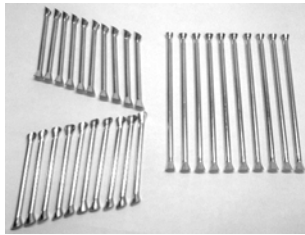

A1519A	19"	1 - 4 Sets	Price Set	\$ 35.00
A1519		5 or more	Price Set	\$ 31.50
A1521A	21"	1 - 4 Sets	Price Set	\$ 35.00
A1521		5 or more	Price Set	\$ 31.50

Stone Guards

These are high quality imports, all stainless steel construction with holes for the emblem and crank. All hardware included.

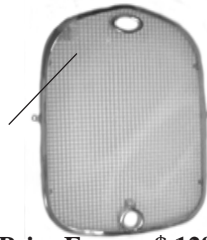

A18700A Shown

A18700A	28-29	23 1/2"	Price Ea.	\$ 129.95
A18700B	1930	25 1/2"	Price Ea.	\$ 129.95
A18700C	1931	24 3/4"	Price Ea.	\$ 129.95



This comes with a stone guard.

A18700SK	28-31	Hardware Kit (Included with stone guard.)	Price Set	\$ 13.95
----------	-------	--	-----------	----------

Luggage Rack

This rack has wooden slats with chrome plated frame. It fits all years and models. For Sedan Luggage Rack Extended brackets - See RAR268 on Page ___.. See car specific sections for Trunks.



A18575B	28-31	Price Ea.	\$ 121.00
---------	-------	-----------	-----------

Luggage Rack Adapter Brackets - Extra Heavy Duty

If your A has the spare tire on the back, you will need a pair of these extension brackets to move the rack beyond the tire. These are powder coated. For Sedan Luggage Rack Extended brackets - See RAR268 on Page Sedan 3.

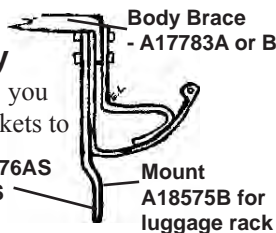

A18576AS or BS

A18576AS	28-29	Price Pair	\$ 35.00
----------	-------	------------	----------

Extra Heavy Duty - Will not bend - 3/8" Steel



A18576BS	30-31	Price Pair	\$ 37.50
----------	-------	------------	----------

Fender Covers

This is a wonderful gift idea. Protect your fenders from dropped tools and belt buckles. These covers are made out of a heavy duty leather grain vinyl with a soft foam back that keeps the fender cover firmly in place. The covers work equally well on both '28-'29 and '30-'31 fenders. If you have a side mounted spare, just cut on the dotted lines.

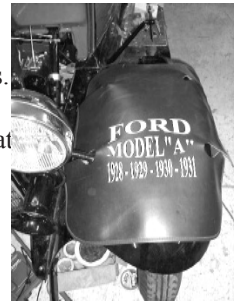

A16156	28-31	Price Ea.	\$ 19.95
--------	-------	-----------	----------

Mud Guards

These will fill the gap between the fender and the bumper on the rear of the car. Hold these plates in place with the bumper end bolt. Powder Coated Black. Currently only available for '28 - '29's.



A16158	28-29	Price Pair	\$ 23.95
--------	-------	------------	----------

Spring Covers (Front & Rear)

Oiled strips of felt smooth your ride by oiling springs and keeping dirt out. Set includes a pair for front and rear springs.



A5310CO	28-31	Price Set/4	\$ 34.35
---------	-------	-------------	----------

Firewall Insulator

If you tour in the heat of the summer (and who doesn't?), you'll want one of these insulators to keep engine heat out. It mounts inside the firewall and is molded to look like the firewall.

A18572A Shown

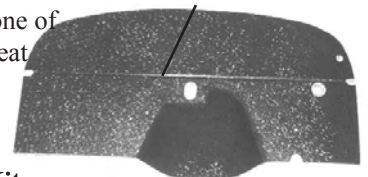

See Complete Car Insulation Kits under the Car specific categories.

A18572A	28-29	Price Ea.	\$ 120.00
A18572B	1930 - 1931	Price Ea.	\$ 120.00
A18572C	1931 - Indented	Price Ea.	\$ 120.00

Data Plate Rivets

This pack of 12 rivets will attach your data plate on the A.



#100	28-31	Price Set/12	\$ 1.50
------	-------	--------------	---------

ACCESSORIES & GIFTS

Order online at www.mikes-afordable.com and get a 5% Discount !!

Gen.17

Mike's "A" FORD-ABLE Parts

Data Plate

All A's had this Ford data plate mounted on the outside of the fire-wall on the passenger side. For Murray and Briggs Data Plates see the Car Specific Sections on Fordor on **Page Sedan 3** and Cabriolet on **Page Spec. 3**.

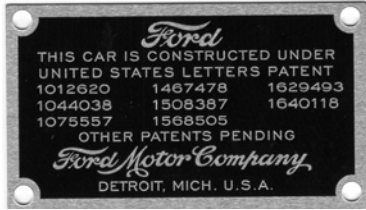

A18650 **28-31**
A18650C **28-31**

Canadian



Price Ea. \$ 1.50
Price Ea. \$ 2.00

Owners Plate

You can personalize this plate with your name and model year and rivet it to the firewall.

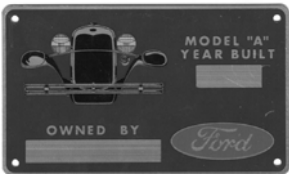

A18650OP **28-31**



Price Ea. \$ 6.95

Complete Turn Signal Kit (6 or 12 Volt + or -)

Now you can have super bright Amber LED turn signals for your "A"! Kit includes super bright LED turn signals, stainless steel brackets, controller and wire. The easy hookup connects to 6 Volt OR 12 Volt cars with negative or positive ground without even flipping a switch. The kit features all solid state components (there are no turn signal flashers to wear out and the LED's will last for over 25 years!). The whole kit is bolted on so you don't have to permanently modify your car. Slim line turn signals mount to bumper clamp bolts and have a one wire hook up. Each turn signal is individually short circuit protected so if one wire shorts to the chassis, only that one light won't come on. Eliminate the short and the turn signal will work again. Also has a hazard light function and is backed by a one year manufacturer's warranty. 20 Piece Set.



A13311A **28-31**

Price Kit/20 \$ 169.95

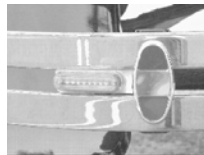

Custom LED Third Brake Lights

Custom LED Third Brake Light fits in the back window of cars and trucks. Strong, twin suction cups attach the rugged, black ABS case to the glass in the back window. Two wire, easy hookup works with 6V or 12V negative or positive ground vehicles. Electronics feature all solid state components (nothing to wear out and the LEDs should last for over 25 years!). No permanent modifications to your car are required. Kit comes with Third Brake Light, harness, connectors, mounts, and suction cups. Logo Lites Custom LED Third Brake Lights are backed by a one year manufacturer's warranty.



A13312S	STOP	Price Kit	\$ 72.00
A13312A	1928	Price Kit	\$ 72.00
A13312B	1929	Price Kit	\$ 72.00
A13312C	1930	Price Kit	\$ 72.00
A13312D	1931	Price Kit	\$ 72.00

A custom Third Brake Light is available. Any 4 Characters of your choice is available, eg MIKE.

A13312O	Special 4	Price Kit	\$ 99.65
----------------	------------------	------------------	-----------------

Each Body Style Specific Section has a Turn Signal Section with more available options.

Radiator Wall Clock

Battery operated clock for your workshop. Fashioned after the '28-'29 Radiator Shell. Approx. 11" x 8" - Ideal for Dad's Birthday, Anniversary or Christmas Present.



A18659 **Price Ea. \$ 35.00**

Ignition Key Fobs

Leather key fobs for each year the A's were made.



A11576A	1928	Price Ea.	\$ 4.25
A11576B	1929	Price Ea.	\$ 4.25
A11576C	1930	Price Ea.	\$ 4.25
A11576D	1931	Price Ea.	\$ 4.25

Key Fob

A Beautiful die cast Nickel plated key ring. Made to look like the original Ford Employee Badge, except that this has 1928 - 1931 across the top instead of the employee number.



A11576E **28-31** **Price Ea. \$ 17.25**

ACCESSORIES & GIFTS

Gen.18 Give us a call - 1-888-TRY-MIKE (879-6453) **Have an "A" Day!**

Mike's "A" FORD-ABLE Parts

Hat Pins

A beautiful accessory to add onto your cap. Comes in each of the 4 Model A years.



A18828	1928	Price Ea.	\$ 4.00
A18829	1929	Price Ea.	\$ 4.00
A18830	1930	Price Ea.	\$ 4.00
A18831	1931	Price Ea.	\$ 4.00

License Frames

Show your pride and let others know what year you've got with these aluminum frames with blue lettering on white.



A13146A	1928	Price Ea.	\$ 7.50
A13146B	1929	Price Ea.	\$ 7.50
A13146C	1930	Price Ea.	\$ 7.50
A13146D	1931	Price Ea.	\$ 7.50

License Plates

Show your pride with these blue Ford script with red model year license plates. Mount on the headlight bar or as an extra on the right side.



A13147A	1928	Price Ea.	\$ 8.50
A13147B	1929	Price Ea.	\$ 8.50
A13147C	1930	Price Ea.	\$ 8.50
A13147D	1931	Price Ea.	\$ 8.50

License Plate Reflector Bolts

A reproduction of an aftermarket accessory. These bolts are sold in pairs and available in 4 different colors.



A13408	Blue	Price Pair	\$ 1.00
A13409	Amber	Price Pair	\$ 1.00
A13410	Green	Price Pair	\$ 1.00
A13411	Red	Price Pair	\$ 1.00

Wallpaper Border

A wonderful finishing touch for your office or shop. Pre-pasted vinyl wall paper strips. There are two different designs to choose from - Commercial or Passenger. 15' X 6.875".

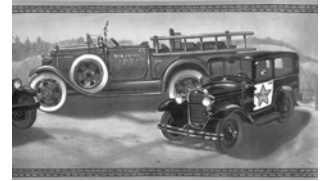

A18820

Commercial Border

Price Roll \$ 10.50



A18825

Passenger Border

Price Roll \$ 10.50

Order Online Now and Save 5%

Visit our website for all your Model "A" needs



www.mikes-afordable.com

ACCESSORIES & GIFTS

Order online at www.mikes-afordable.com and get a 5% Discount !!

Gen.19

Mike's "A" FORD-ABLE Parts

SIGNS & MAGNETS

SIGNS & MAGNETS

"Authorized FORD Service Station"

Porcelain enameled Signs.
18" x 8" with white letters on
a blue background.



A18806 Price Ea. \$ 18.00

"Authorized FORD Service"

10 3/4" x 18" sign with white letters on
blue background.



A18807 10 3/4 x 18" Price Ea. \$ 18.00

"Genuine Ford Parts Used Here"

6" x 22" sign with white lettering on a
blue background.



A18812 Price Ea. \$ 19.50

"Ford, The Universal Car"

18 x 7 3/8" sign with white
lettering on a blue background.



A18814 Price Ea. \$ 18.75

"Sales & Service, Authorized Dealer"

16" x 10.5" Tin Sign.



A18826 Price Ea. \$ 12.95

"Genuine Ford Parts"

11.75" Diameter Tin Sign



A18827 Price Ea. \$ 11.95

Look But Sign

Keep this metallic sign handy
when going to shows. Tells
people "Look but
Please Don't Touch!"



A18817 Price Ea. \$ 4.95

Look and Enjoy Sign

Another handy metallic sign, that
states "Look and Enjoy.....but
Please Don't Touch!"

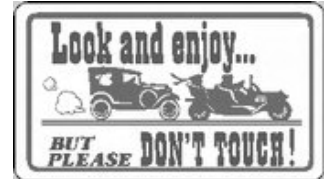

A18818 Price Ea. \$ 4.95

"Genuine Ford Parts" Refrigerator Magnet

Made of mylar on Magnet backing.
Oval Magnet - 2" x 1".



A18823 Price Ea. \$ 6.00

"Authorized Ford Service" Refrigerator Magnet

Porcelain Magnet.
Square 1 1/2" x 2 1/4"



A18824 Price Ea. \$ 8.00

TOOLS

Tool Boxes

The best on the market today!!

A hand made locking tool box which fits between the frame horns on the front of your Model A. Due to the aerodynamic design of the tool box, it not only looks beautiful, but also assists with the cooling on your Model A. Powder Coated Black.

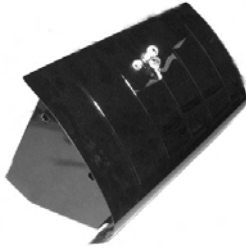

You will notice that this will block your crank hole, so we have made a tool that enables you to time your engine from the inside Ratchet Nut - See **T6253** - See page 24.

T1000	28-29	Price Ea.	\$ 185.00
T1005	30-31	Price Ea.	\$ 185.00

Wire Wheel Spoke Straightener

This is an exact copy of the original spoke straightener. Very useful tool to get those bent spokes back into position.



T1018		Price Ea.	\$ 58.95
--------------	--	------------------	-----------------

Hub Stud Bolt Swage

A 20 - 30 Ton hydraulic press must be used with this tool to install hub bolts. This is known as swaging.



T1109T	28-31	Price Ea.	\$ 9.95
---------------	--------------	------------------	----------------

Rear Hub Puller

No more hard Pulling!! This pulls the rear hubs free from the axle. An exact copy of the K. R. Wilson Tool.



T1114T	28-31	Price Ea.	\$ 144.95
---------------	--------------	------------------	------------------

Hub Cap Tool

Thanks to the unique design of this tool, the hub cap is easily and firmly secured to the wheel, virtually eliminating distracting rattles and lost hub caps caused by poor installation.



T1130	30-31	Price Ea.	\$ 57.50
--------------	--------------	------------------	-----------------

Rear Hub Puller

A more economical hub puller to use. Please be sure to check your hubs, and order accordingly, as there are 2 possible versions of hubs.



T4239A	1928 Protruding Ring Style	Price Ea.	\$ 33.00
---------------	-----------------------------------	------------------	-----------------

Shown on Hub



T4239B	1929 - 1932 - Recessed Ring Style	Price Ea.	\$ 33.00
---------------	--	------------------	-----------------

Track Rivet Tool

Use this tool to keep from damaging the heads on the A2013 Rivets, by placing them in the center, and using it as a Bucking Bar when peening.



T2013T	28-31	Price Ea	\$ 1.50
---------------	--------------	-----------------	----------------

Brake Riveting Tool

This is an invaluable tool for the DIYer. It comes complete with a punch to remove old rivets, a tool to drill and countersink lining, and a tool to install new rivets. New Hardened Tools.

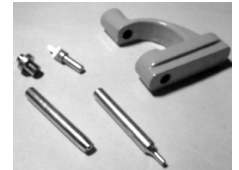

T2018	28-31	Price Set/5	\$ 27.50
--------------	--------------	--------------------	-----------------

Replacement Riveting Tools for the T2018

Hardened heat treated replacement tools for the T2018.



T2019	28-31	Price Set / 4	\$ 9.00
--------------	--------------	----------------------	----------------

Brake Adjusting Tool

A very handy tool to adjust your brakes by pushing the brake pedal down to a specific distance so you can adjust each wheel. The brakes are adjusted at the wheels in relation to how far the brake pedal is depressed. The top of the tool hooks around the steering wheel.



T2012	28-31	Price Ea.	\$ 27.95
--------------	--------------	------------------	-----------------

Brake Adjustment Wedge Tool

This is the correctly angled tool to use to adjust your brakes.

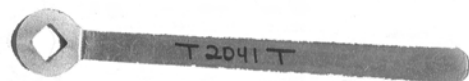

T2041T	28-31	Price Ea.	\$ 8.75
---------------	--------------	------------------	----------------

TOOLS

Front Brake Lever Shaft Bushing Reamer

1/2" Long fluted .559 reamer to reach both bushings. See Mike's Tips on Page Gen. 49.



T082R **28-36** **Price Ea.** **\$ 117.50**

Rear Brake Camshaft and Emergency Toggle Lever Reamer - USA

Quality Spiral Hand reamer, reams the Rear Brake Camshaft Bushings (A2227). This is a fluted reamer - 5" long to reach both bushings in one operation. Ream to .688. See Mike's Tips on Page Gen. 49.



T227R **28-31** **Price Ea.** **\$ 56.95**

Rear Brake Camshaft Bushing Reamer

Adjustable Reamer for the Rear Brake Camshaft Bushings (A2227) and also the Emergency Toggle Lever Bushings. Reams to .688. See Mike's Tips on Page Gen. 49.



T227AR **28-34** **Price Ea.** **\$ 27.95**

Brake Buddy

Great new tool to keep under your seat for adjusting your brakes in a hurry. Complete Instructions included.



T499 **Price Ea.** **\$ 19.95**

Front Spindle Bolt Bushing Reamer

1/2" Long reamer to ream both bushings in line. Reams to .814. See Mike's Tips on Page Gen. 49.



T112R **28-31** **Price Ea.** **\$ 135.00**



T112TR **Price Ea.** **\$ 29.95**

Tie Rod & Drag Link End Plug Tool

You can remove the threaded end plugs on the tie rod and drag link ends with this tool. Use a 7/8" wrench.



T305T **28-31** **Price Ea.** **\$ 5.00**

Race Driver Tool

Use this tool to install the A3552 bearing in the bottom of the box on your two tooth steering gear box.



T3552 **28-31** **Price Ea.** **\$ 38.95**

Steering Wheel Puller

This helpful tool removes the steering wheel from the steering shaft. Contains 2 Pulling Plates. One for the '28 - '29 Steering Wheel and the other for the '30 - '31 Steering Wheel.



T3600P **28-31** **Price Ea.** **\$ 41.95**

Light Switch Spider Tool

Tape the horn button down with a piece of masking tape or have someone hold the button down for you. Now insert the light switch spider over the legs of the tool, slide the spring onto the spider and push them both onto the horn rod making sure you have the ears lined up correctly. Push far enough so you can install the retainer, then remove the tool and you have just installed the spider and retainer easily. The spring A3642, Spider A3643 and Retainer A3644 are sold separately.

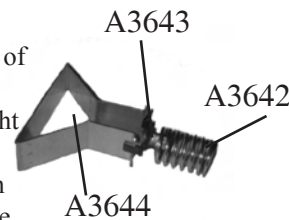

T3643 **28-31** **Price Ea.** **\$ 5.50**

Universal Bushing Installation & Removal Tool

An ideal Tool to remove bushings from Rear Brake Camshaft, Rear & Front Spring and Perch Bushings.

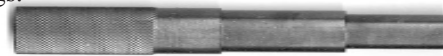

T3820/44T **28-31** **Price Ea.** **\$ 10.95**

Pinion Puller

Don't risk damaging your drive shaft threads.



T4210T **28-31** **Price Set/5** **\$ 38.50**

Knock-Off Wheel Puller

To remove your hub from the axle, remove the axle nut and screw this long one on. Jack up the opposite wheel and hit this to break the hub free. This may not loosen rusted or very tight Hubs - Use T1114T for this - see Page Gen. 21.



T4235WP **28-31** **Price Ea.** **\$ 3.75**

Economy Seal Driver

An inexpensive tool to install the axle seals. Inside is threaded to screw your own pipe on.



T4246 28-31 Price Ea. \$ 7.00

Pinion Nut Wrench

High quality steel wrench with good design to install or remove the pinion nut.



T4634T 28-31 Price Ea. \$ 16.95

Traveling Spring Spreader (Rear)

This compact spreader is for the rear leaf spring. Set one end against the rolled end of the spring and the other on the opposite housing bolt, and start spreading.



T5300 28-31 Price Ea. \$ 34.50

Front Spring Spreader

Safely spread the front leaf spring to remove the spring or to replace the shackles.



T5301 28-31 Price Ea. \$ 58.95

Front Spring Spreader

No Model A Shop should be without this tool! There is no tool on the market today to compare with this one.



T5301MOD Price Ea. \$ 96.00

Rear Spring Spreader

This heavy duty spring spreader, has long legs, end pads are notched to fit the rolled end of the spring. No slipping, comes with 1 1/2" Wrench for turning nuts.



T5302 28-31 Price Ea. \$ 98.75

Rear Spring Spreader

No Model A Shop should be without this tool! The best and safest tool on the market. This is a 1 piece design - no legs to fit - adjusting rod supplied. There is no tool on the market today to compare with this one.



T5302MOD Price Ea. \$ 136.00

Shackle Bushing Reamer

Adjustable Reamer. An Inexpensive Import that will get the job done. See Mike's Tips on Page Gen. 49.



T5303TR Price Ea. \$ 24.50

Shackle Bushing Reamer

Hand Reamer for the rear and front shackle bushings. See Mike's Tips on Page 49.



T5303R Price Ea. \$ 72.00

Shackle and Front Perch Bushing Drill Bit

Drill your shackle bushings to the proper bore. An alternative to an expensive reamer. 14.5 mm bit with 1/2" shank. Bushings included with shackle kits do not need to be reamed.



T5303D 09-31 Price Ea. \$ 15.00

Cylinder Head Puller and Engine Lifter

This new tool can be used to pull the engine, or just for lifting the head. The puller comes with special hardware.



T6010P 28-34 Price Ea. \$ 69.00

Head Nut Torque Tool

You no longer have to remove the distributor!! Use this new tool to torque the nut that hides behind the distributor.



T6064T 28-31 Price Ea. \$ 22.50

Stud Installation and Removal Tool

Use this tool for installing or removing studs on your cylinder head.



T6065 28-31 Price Ea. \$ 39.00

Stud Thread Repair Kit

Sooner or later we all have to repair threads in our block. This Heli-Coil kit has everything you need except the drill bit. (Use a 29/64" tap drill bit).



T6065RK 28-31 Price Set/8 \$ 26.00

Mike's "A" FORD-ABLE Parts

Piston Ring Compressor Tool

If you do your own work, you will need one of these to make installation of rings a breeze.



T6149T 28-31 Price Ea. \$ 9.75

Cam Shaft Nut Tool

Remove or install your cam nut with this special tool that won't damage the nut.

Use a 1 1/8" socket with this tool.

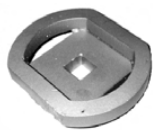

T6251 28-31 Price Ea. \$ 19.25

Timing Kit

Set your own timing with this complete kit with instructions. A timing light is needed for this kit.



T6252 28-31 Price Kit/5 \$ 31.50

Timing Wrench

This wrench is designed to easily rotate the crankshaft of your Model A to determine top dead center. Comes with complete instructions. **WARNING! Please read and follow all directions carefully.**



T6253 28-31 Price Ea. \$ 39.95

EZ Timing Pin Setter

Shown with and without timing pin (not included). This is an amazing little tool - once you have used it you will tell all your friends.



T6254 28-31 Price Set \$ 9.50

Ratchet Nut Wrench

This handy tool lets you remove or tighten the nut without removing the radiator.



T6320 28-31 Price Ea. \$ 39.25

Flywheel Gauge

Use the small bracket in this kit to determine if the flywheel is seated properly on the crankshaft. The large bracket bolts to the flywheel, then turn the flywheel so that you can be sure that the flywheel housing is correctly shimmed against the block.

Both of these areas can cause vibrations if not properly done

T6381 28-31 Price Ea. \$ 36.00

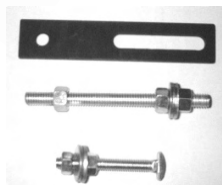

Valve Guide Removal Tool

The best on the market. This is a duplicate of the K.R. Wilson tool used for the Model A Engine.



T6511 28-31 Price Ea. \$ 13.50

Valve Lapping Tool

Rubber suction cups stick to the valves, which in turn spins the valve, grinding it into the seat.



T6512 28-31 Price Ea. \$ 7.05

Valve Spring Compressor Tool

This tool makes the job so easy. Place the hook over the manifold stud, and it acts as a pivot to pry the spring up to install the keeper.



T6513T 28-31 Price Ea. \$ 41.95

Thread Repair Kit

Do you have a stripped oil drain plug hole? Use this special adapter which threads into the oil drain and cuts new threads for you.

No need to remove the engine from the car. A new smaller drain plug is included with the set. See A6733 for Weld Thread Repair on Page Gen. 119.



T6731 09-31 Price Set \$ 13.50

Gear Shift Lever Spring Removal & Installation Tool

This tool comes complete with instructions, for the removal or installation of your gear shift lever spring.



T7226T 28-31 Price Ea. \$ 41.00

Clutch Disc Alignment Tool

This helpful tool aligns the disc with the pilot bearing when you are installing a new clutch disc. Place the correct side of the clutch disc, (shortest side of the hub) against the flywheel - install the pressure plate using 12 bolts (A7563MB).

Do not tighten the bolts. Now, using your align tool, center the clutch disc onto the pressure plate and carry on inserting the tool into the pilot bearing. Then torque down the bolts to the flywheel - then remove the tool.

See Page Gen. 5 for torque info.

T7550T 28-31 Price Ea. \$ 3.95



Gen.24 Give us a call - 1-888-TRY-MIKE (879-6453) **Have an "A" Day!**

Pedal Bushing Reamer

This reamer will ream both bushings in each pedal or the bushings in the bell housing for the clutch release shaft. Ream to .874. See Mike's Tips on **Page Gen. 49**.



T7508TR Price Ea. \$ 32.95

Water Pump Wrench

Specially designed for the water pump packing nut. Do not overtighten. This is **NOT** used on Mike's Ultimate Water Pump - **A8501B** or **A8501Z**.



T8501W 28-31 Price Ea. \$ 1.60

Fan Knock Off Tool

This innovative little tool will help you to remove your fan. Simply thread this special nut onto the end of the shaft, hold the fan and give the tool a couple of good hits to break the fan loose from the shaft.



T8600T 28-31 Price Ea. \$ 1.95

Gas Tank Filler Screen Tool

A great tool to help with the installation or removal of the Filler Screen (**A9020**). Place the tool in the filler neck notches and use a socket wrench and extension. Please note that this will only work on an original screen. The reproduction screens do not have the notches.

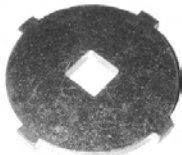

T9021 28-31 Price Ea. \$ 3.75

Gas Gauge Tool Set

Safely work on your gas gauge with this cast aluminum heat treated tool set. Will not damage nuts.



T9300 28-31 Price Set/2 \$ 6.45

Carburetor Rebuilding Wrench

This is a copy of the KR Wilson tool used to rebuild Zenith Carburetors.



T9511 28-31 Price Ea. \$ 11.50

Carburetor Jet Tap

This special tap is to clean the jets on the Zenith carburetor. This is a 5mm 75 Pitch tap.



T9574 28-31 Price Ea. \$ 6.25

Generator Pulley Adapter

If you have the earlier long nose generator and cannot find the correct pulley, you can now use the more common short nose pulley with this adapter.



T10144R 28-31 Price Ea. \$ 2.45

Modern Bendix Drive Installation Tool

A handy unit to help with the installation of the modern drive **A11350M** - See **Page Gen. 166**. Instructions Included.



T11350 28-31 Price Ea. \$ 17.50

Polarity Tester

Put this between the distributor cap and the coil wire to insure the coil is properly wired. A great tool to have. Complete with instructions. 6V or 12 Volt.



T12116 28-31 Price Ea. \$ 22.50

Spark Tester

Test your ignition voltage by placing this between the distributor cap and the coil wire. Can also help start flooded engines. Complete instructions.



This shows how much voltage the system is generating.

T12117 28-31 Price Ea. \$ 18.50

Ignition Tester

Hold this handy tool against the spark plug while the car is running, to see if you are getting spark to the plug.

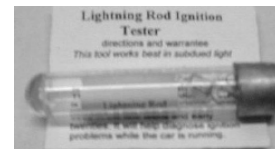

T12118 28-31 Price Ea. \$ 10.50

Distributor Puller

This will safely remove the distributor from the head without breaking the distributor casting.



T12130DP 28-31 Price Kit \$ 31.50

Distributor Bushing Reamer

A quality made spiral piloting reamer. Aligns both bushings while reaming. Not a cheap import. See Mike's Tips on **Page Gen. 49**.



T12132R 28-31 Price Ea. \$ 68.50

Mike's "A" FORD-ABLE Parts

Distributor Reamer

For the Distributor or Oil pump bushings.
This is the cheaper import, but will not do both bushings at the same time.

See Mike's Tips on
Page Gen. 49.



T12132TR 28-31 Price Ea. \$ 21.50

Distributor Cam Wrench

Holds the cam in place, so you can tighten the cam screw, after you set the ignition timing.



T12210CW 28-31 Price Ea. \$ 1.15

Z Distributor Cam Wrench

No need to remove the distributor body.
Fits directly onto the cam for adjusting.



T12210Z 28-31 Price Ea. \$ 2.40

Cowl Light Marking Tool

This little tool takes the guesswork out of deciding where to drill new holes when installing a cowl light.

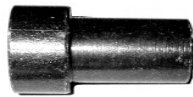

T13300X 28-31 Price Ea. \$ 4.25

Tool Bag

This is a nice heavy duty tool bag to keep your tools clean and together. Cobra style top material.

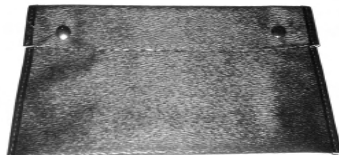

T17005 28-31 Price Ea. \$ 8.95

Tire Irons

All Tire Irons are tempered for strength. Blunt on one end.
10" Long.



T17019A October 1927 - July 1928
Price Ea. \$ 18.25

Screw Driver Point on one end.
10" Long.



T17019B July 1928 - November 1928
Price Ea. \$ 18.25

Spoon on one end.
10" Long.



T17019C December 1928 - End
Price Ea. \$ 17.15

Twist Style, Screw driver point on one end.
19 3/4" Long.



T17019D Late 1931 Price Ea. \$ 20.15

Engine Lifter - Puller

Used to remove engines and stock cylinder heads. Using 2 makes the job a little easier.



T17022 28-31 Price Ea. \$ 10.25

Crank

This dual purpose tool can use one end to crank your car and the other to change a tire.



T17036 28-31 Price Ea. \$ 11.95

Tire Gauge Stem Tool

This is a brass, chrome plated tool. Has a female thread.



T18100S Price Ea. \$ 16.30

Grease Fitting Tool

This little tool is helpful when you install the press-in style grease fittings.



T353020 28-31 Price Ea. \$ 3.00

TOOLS

Mike's "A" FORD-ABLE Parts

Grease Gun Adapter

This adapter can screw onto a regular gun to enable it to be used to grease the old style grease fittings.



T353032 28-31 Price Ea. \$ 3.00

Snap Fastener Tool

This useful tool is for fastening the snap style fasteners - U7677E and U7678E.



T37106T 28-31 Price Ea. \$ 4.95

Top Bow Tool

A handy tool to attach the wood bows to the metal top irons. Tool is made for standard air hammers and gives the rivet a truss head appearance.



T43501T 28-31 Price Ea. \$ 38.00
A43501R Rivets Price Ea. \$ 0.40

Hinge Pin Remover

This helpful tool, uses three graduating hardened push pins to push your old hinge pins up and out of the hinge. As you tighten the bolt it will push the dowel and the old pin out. Set comes complete with 3 different length push pins and complete instructions. **NOT to be used on Slant Windshield Cars. This item is NOT Refundable!!**

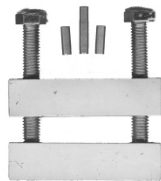

T46335HR 28-31 Price Ea. \$ 28.75

WARNING!!!

If your dowel pins start bending **DO NOT** go any further with this tool. These dowels are made from a hardened steel but **NOT** case hardened. The manufacturer has issued a warning that if a case hardened or heat treated steel was used, it could very well explode or splinter under such pressure, and possibly do bodily harm. I suggest trying penetrating oil, but if that doesn't work, then take a fine drill bit and try drilling at least halfway through the pin. Then use the removing tool.

Drill Out Tool

If you are drilling out the old rivets, use the drill out tool that fits over the round head to hold it steady.



RA1010 Price Ea. \$ 21.50

Bucking Bar

The bucking bar lets you hold the round head of the new rivets while you peen the other end.



RA1012 Price Ea. \$ 21.00

Waffle Tool

This is used to peen the end of new rivets. It will fit any air hammer.



RA1011 Price Ea. \$ 27.50

Manual Rivet Tool

For setting solid rivets and giving them a rounded peen. It is best to set them hot.



RA1013 For 1/4" Rivets Price Ea. \$ 24.25

RA1014 For 3/16" Rivets Price Ea. \$ 24.25

Air Rivet Tool

Use this tool for setting solid rivets and giving them a round peened appearance. Fits standard air hammers.



RA1015 For 1/4" Rivets Price Ea. \$ 37.50

RA1016 For 3/16" Rivets Price Ea. \$ 37.50

Tubular Rivet Tool

This hand held tools will get the job done. Used on door latches, windshield brackets, floorboard irons, shift plate clips, and transmission fork pins.



RA1017 3/16" Price Ea. \$ 32.95

Tubular Rivet Tool

This tool will be useful for installing the rivets on the crank hole cover & the '30-'31 Cowl Lamp Light Socket.



RA1018 1/8" Price Ea. \$ 32.95

TOOLS

Mike's "A" FORD-ABLE Parts

Tubular Rivet Tool

Use this tool for installing the brake lining, hood handles, hood bumpers and hood clips.



RA1019 9/64" Price Ea. \$ 29.95

Rivet Jacks

An adjustable tool that is used for bucking the heads of rivets in tight areas.

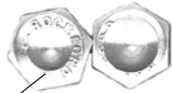

RA1020 For 1/4" Rivets Price Ea. \$ 9.50
RA1021 For 5/16" Rivets Price Ea. \$ 9.50

Rivet Tool

This is a hand held tool, with a special end that will roll a tubular rivet like a professional. This tool also includes a bucking bar. Has a concave head to fit the rivet head, to support the rivet while you give it a hit on the head.



RA2022 28-31 Price Set/2 \$ 9.75

Side Curtain Fastener Tool Set

Use this tool to install the Side Curtain Fasteners (UF40). See Page Gen. 233.



UF40T 28-31 Price Set \$ 14.25

Body Sockets Installation Tool - Open Cars

This is the tool for the A81002 Sockets. See Page Gen. 233.



T81002T 28-31 Price Ea. \$ 1.50

Lift the Dot Socket Tool - Open Cars

This is the Tool to install the UF16 - Lift the Dot Sockets with prongs. Punches a hole and 4 slits in the perfect location for mount the Sockets.



UF16T 28-31 Price Ea. \$ 49.95



Mr. Ron Derenzis' 1931 Roadster on tour with the GA Region MARC in Savannah, GA.



Picture from Mr. W. T. Higgins.
" the first car I ever rode in, both before and after I was born!"

TOOLS

RESTORATION SUPPLIES

Gas Tank Sealer

Extend the life of your old tank with this semi-elastic sealant. Seals pin holes, covers rust flakes, not affected by alcohol. **Cannot be shipped by air.** For best results, have the gas tank chemically cleaned and rust free before using this sealer.



AGTS 28-31 Price Quart \$ 25.00

Top Dressing

This black top dressing brushes on to give your top a new look.



ATD ANY Price Quart \$ 17.50

600-W Oil with Pour Spout

This is the correct viscosity, custom formulated for Mike's, extra heavyweight oil you'll need for the rear end, the transmission, and the steering box. The rear end takes 1 1/2 Pints; the transmission. 1 Pint; and the steering box, 7 3/4 ozs.



A600W 28-31 1 Quart
Price Ea. \$ 9.95

Kozak Auto Dry Wash Cloth

The Kozak Dry Wash cloth is a specially woven, deeply napped all-cotton cloth treated with a unique formula that pulls the dirt and dust deep into the napping and away from the car's surface. Kozak was introduced in 1923 to satisfy the need of Ford and other car dealerships to keep their new cars clean. As streets were almost all dirt, airborne dust was a very big problem - especially for all of those black cars! And this kind of dusty dirt is where Kozak really shines.



A1050KZK 28-31 Price Ea. \$ 7.99

Wheel Bearing Grease

This can of heavy duty grease is what you need when you repack your wheel bearings.



A1220 Any Price Ea. \$ 6.60

Heat Resistant Spray Paint

Resists heat up to 1500 deg. for manifolds and mufflers. Spray on clean metal, no primer needed. Spray only enough to cover metal, do not over paint. 12 Oz. Can.



Cannot be shipped by air.

A5240 Black Price Ea. \$ 9.95
A5241 Cast Iron Gray Price Ea. \$ 9.95

Muffler Cement

This cement is used between the Exhaust Sleeve A5234 on Page 96 and Exhaust Seal A5251ES on Page 96 to eliminate leaks.



A5253 Price Ea. \$ 3.25

Head Gasket Sealant

Mike recommends this sealant.

Always helpful, usually needed. Spray both sides of your head gasket and it will fill in minor imperfections in your head or block. Do not use with our modern gaskets A6051M or B6051M.



Cannot be shipped by air.

A6052S 09-31 Price Ea. \$ 9.50

Safety Wire

.040 od. Stainless Wire to secure the Torque Tube, Rear Motor Mount, Flywheel to crank and block, Tran. rear bushing retainer, rear axle gear case. 230 Ft. per Roll.

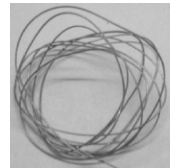

A6377 Price Foot \$ 0.30
A6377A Price Roll \$ 60.00

Valve Grinding Compound

See Page 24 for the Lapping tool. This compound is used to seat in valves. 1.2 Oz. Tube.



A6509 Price Ea. \$ 4.95

Water Pump Grease

Modern, multipurpose grease can be used for water pump and chassis. Water proof and withstands high temps.



A8500 Any Year Price Ea. \$ 6.25

RESTORATION SUPPLIES

Mike's "A" FORD-ABLE Parts

Gas Tank Etching

Remove light rust inside of your gas tank before you put in the AGTS Gas Tank Sealer. This will leave a gray phosphate coating. 16 Oz.



A9002E 28-31 Price Ea. \$ 11.75

Distributor Cam Lube

This specially-blended lube is just what you need for your distributor cams. Your points will last longer and you'll have better performance.



A12210L ANY Price Ea. \$ 7.25

Running Board Cover Glue

Use this special black contact glue when installing your rubber matting A16450/51RM or A16450/51PM.



A16450CEM 28-31 Price Ea. \$ 16.50

Speedo Lube

If your cable is OK, but not turning smoothly, get this 7CC packet of graphite lubricant.



A17260L ANY Price Ea. \$ 2.95

Engine Paint

You'll need one spray can of this Model A Ford green paint if you're touching up your engine; two if you are repainting a complete engine. 12 Oz Can.

Cannot be shipped by air.



M200 28-31 Price Ea. \$ 4.65

Engine Paint - Quart

This quart can of the Model A Ford green is ideal for touching up the little nicks that occur.



M210SP 28-31 Price Quart \$ 15.75

White Lithium Grease

1.25 oz tube. Use to lubricate parts during assembly. Provides all temp. protection and also protects against rust. A great grease for brake parts, gear shift mechanisms, steering linkages, hoods, doors and trunk latches, speedo cables, seat tracks, etc.



M534 28-31 Price Ea. \$ 2.95

Shock Fluid

This pint-sized plastic bottle is enough to do all four shocks. Shock Fluid only for original shocks. Mike's Shocks are sealed units and no fluid is needed.



M1046 28-31 Price Ea. \$ 3.25

Simichrome Polish

This is an excellent polish that cleans brass, nickel, chrome, and aluminum to a bright shine and leaves a protective finish.



M6067SPOL ANY Price Ea. \$ 5.95

Permatex Gasket Sealant

The best sealants for Model A Gaskets. Aircraft approved.



PGS 4 FL Oz. Price Ea. \$ 5.50

Plastigage

Use this thin waxed string to help check the clearance on the connecting rods and main bearings. Bearing clearance for both rods and mains is .0015.



PG1 Range .001 - .003 Price Ea. \$ 3.00

PG2 Range .002 - .006 Price Ea. \$ 3.00

Permatex Prussian Blue

Used for precision fitting of valves, gears, bearings & most other machined surfaces. 3 Ounce tube.



PG3 28-31 Price Ea. \$ 3.95

RESTORATION SUPPLIES

GREASE FITTINGS

Modern Grease Fitting Set

If you want to make maintenance simpler, convert your original grease fittings to these so you can use the modern grease gun. This set has all the fittings you'll need to do it right.



A353000 **28-31** **Price Set** **\$ 18.75**

Original Grease Fitting Set

All the correct sizes you will need for your restoration.



A353000OR **28-31** **Price Set** **\$ 18.95**

Grease Fitting Tool

This little tool is helpful when you install the press-in style grease fittings.



T353020 **28-?** **Price Ea.** **\$ 3.00**

Fitting Adapters

If the original press-in fitting has been drilled and tapped, screw these adapters into the tapped hole and you can press in the original style fittings.



A353021 **28-31** **Price Ea.** **\$ 1.95**

Grease Gun Adapter

This adapter can screw onto a regular gun to enable it to be used to grease the old style grease fittings.



T353032 **28-31** **Price Ea.** **\$ 3.00**

Original Style Fittings

You'll need 16 of these 5/16" straight drive in style fittings.



A353026 **28-31** **Price Ea.** **\$ 0.50**

Original Style Fittings

You'll need 10 of these 3/8" threaded fittings.



A353027 **28-31** **Price Ea.** **\$ 0.60**

Original Style Fittings

You'll need 2 of these 25% fittings for the front spindles.



A353029 **28-31** **Price Ea.** **\$ 0.90**

Original Style Fittings

You'll need 4 of these tube link fittings which are used on the original tubular shock links.



A353031 **28-31** **Price Ea.** **\$ 1.95**

Water Pump Grease Fitting

Special brass fitting with a screw on cap for rear bushing assembly of the pump.



A8501FIT **28-31** **Price Ea.** **\$ 3.00**

Mike's "A" FORD-ABLE Parts

WELTING & BEDDING

Open Car Glass Bedding

The correct cork / neoprene bedding used for setting glass into the windshield frame.



A3402X 28-31 Price Roll \$ 7.50

Closed Car Glass Bedding

The correct cork / neoprene bedding to be used for setting the glass in the windshield frame.



A3403X 28-31 Price Roll \$ 7.50

Fender Welt

Mike has this 17 foot roll of the 3/16" black beading used on the fenders.



A3404FW 28-31 Price Roll \$ 9.90

Cowl Welt

This roll of 1/8" black beading is used when you mount your gas tank.

'28-'29 - Across back edge of tank and down sides of cowl.

'30-'31- Around back edge and sides Paint Lower body color



A3405CW 28-31 10' Roll Price Roll \$ 3.75

Visor Welt

This goes between the Sun Visor and the Header and is 4' Long.



A3406VW 30-31 Price Roll \$ 1.25

Frame Welt

This treated webbing won't rot away when installed on your frame rails. Enough to do one car.



A3407X 28-31 Price Roll \$ 16.50

Running Board Bracket Anti-Squeak Welt

Place this thin 1/16" anti-squeak material on top of each brace before setting on the running boards. 4' Long x 1/16" x 3/4" woven treated fabric.



A5135 28-31 Price Roll \$ 2.25

Rear Spring Anti-Squeak

This 15" piece of 1/8" x 2" welt fits on the rear floor pan with split rivets - this keeps the pan from rubbing the top of the crossmember. Includes Rivets.



A5701 28-31 Price Ea. \$ 1.50

Gas Tank Anti-Squeak Welt

This 1/16" x 12 ft. woven fabric welt is used as a buffer around the gas tank to eliminate rattles. The early models use it all the way around the tank; the later models on the front and back edges.



A9006 28-31 Price Roll \$ 3.60

Radiator Splash Apron Felt Pads

These felt pads can be riveted or glued between the splash apron and radiator shell to eliminate rattles.

The '28 - '29's use two while '30 - '31's use only one.



A16529AS 28-29 Price Pair \$ 1.25
A16529BS 30-31 Price Ea. \$ 0.75

Radiator Shell Lacing

Double beaded lacing - attaches to the radiator shell. Rivets included. 25 Rivets.



A16739A 28-29 Price Set \$ 6.75

A16739B 30-31 Price Set \$ 9.00

Cowl Lacing Kit & Rivets

Two types are available for the '28-'29 A's. The original used wire to hold the lacing down on the gas tank and rivets on the cowl panels. Use Rivet Tool RA2022.



A16740ARE 28-29 Replacement Price Kit \$ 8.60

A16740AOR 28-29 Original Price Kit \$ 12.75

Cowl Lacing Kit

Just like the original for '30-'31 A's. Complete with all clips, screws, and rivets. Use Rivet Tool RA2022.



A16740BS 30-31 Price Kit \$ 15.45

WELTING & BEDDING

Gen.32 Give us a call - 1-888-TRY-MIKE (879-6453) Have an "A" Day!

Mike's "A" FORD-ABLE Parts

Glass Setting Rubber

This U-shaped rubber is used to mount the rear and quarter windows in the frame.



A19003C	Quarter and rear windows	Price Set	\$ 10.25
A19003R	Rear window only	Price Ea.	\$ 4.95

Rubber Insert for Upper Door Seal

If you are only needing to replace the insert in your channel, A19008A, B or C this will do the job. Used on:

'28-'31 Coupe
'28-'31 Tudor
'30-'31 Pickup
A19008R



28-31 Price Ea. \$ 2.80

Bottom Door Seal

This rubber seal goes on the bottom of the door and is held in place by the same clips that hold the door panel on. 1 Roll is enough for all Closed Cars.



A19009 28-31 Price Roll \$ 6.25

Open Car Bottom Door Seal

This is an 8 foot section of rubber to seal the bottom of the door. Please use A19009 if you have reproduction doors.



A19010 Mid 30-31 Price Ea. \$ 6.95

Floorboard Seal

This black cotton webbing with tacks goes around the floorboard to seal out air and fumes.



A35130S 28-31 Price Ea. \$ 4.50

This kit seals the two additional wood floor pans on the Tudor. For Tudor Rear and Center.

A35130S2 28-31 Price Ea. \$ 6.95

Open Car Windshield Gasket Set

This set of rubber gaskets is used on the open car windshield.



A37199A 28-29 Price Set \$ 4.50
A37199B 30-31 Price Set \$ 4.75

Welting (Wire Welt) - Crown Vinyl Molding

This half round welt (wire welt) is often used in place of the metal roof molding. You nail it down and fold it over to form a nice fabric bead. Measure carefully as scraps cannot be returned. Comes per foot.



A47304 28-31 Price/Ft. \$ 0.90

Split Welting (Hid'em)

This split welting was used on the following trucks: the '28-'29 closed cab; Panel Delivery; and the '31 Special Delivery. This can be used with most models with a wood top.



A47305 28-31 Black Price/Ft. \$ 0.65
A47305T 28-31 Tan Price/Ft. \$ 0.80

Closed Car Windshield Frame Gasket

This gasket goes on the bottom (put in first) and sides of the steel windshield frame. Rubber gaskets stretch when you install them so wait a day to trim for a tighter fit.



A79500 26-31 Price Ea. \$ 3.50

Closed Car Frame Gasket (Aluminum Frame)

For the aluminum frame, this is the gasket to use. This does the bottom and both sides but wait a day to trim because of stretch.



A79501 28-31 Price Ea. \$ 4.15

Closed Car Windshield Hinge Gasket

This gasket is critical to keep out water. It fits between the windshield hinge and the header. Not for Slant Windshield Sedans.



A79550 28-31 Price Ea. \$ 3.00

Closed Car Slant Windshield Gasket

This is the special gasket needed for the Slant Windshields. This has the special hinge, 2 sides and the bottom gasket you'll need.



A79551BR 1931 Price Set \$ 19.95

MISC. HARDWARE

Nuts (Clinch Nuts)

Used on these special clinch D-nuts on the Model A's.

'29 Sun visor, window garnish, cowl, door area.

32



Price Ea. \$ 0.25

'31 Gas tank, rear sub frame

'28-'31 floorboard. Trunk

and Rumble.

24



Price Ea. \$ 0.25

ash rail.

20



Price Ea. \$ 0.25

rear fender brace, 1928 Phaeton,

4 Door and Coupe tail light bracket to body.

26-24



Price Ea. \$ 1.55

rear tire mounting on rear cross frame.

24



Price Ea. \$ 1.35

rear tire carrier for '28-'29 Fordor Briggs

and top support bar on 4 Door Phaetons.

26-20



Price Ea. \$ 1.35

Cotter Pin Set

This is an entire set of cotter pins if you're refurbishing the whole car.

27

28-31



Price Set \$ 5.25

Cotter Pin Set

This is an entire set of stainless steel cotter pins if you're refurbishing the whole car.

27SS

28-31 Stainless steel



Price Set \$ 13.50

Body Nails

Commonly used on all Model "A's"

Nail Style 3



Nail Style 4

Nail Style 5

Nail Style #3

.074 diam. x 3/4" long - oval head - pack of 100

Price Pack \$ 1.50

Nail Style #4

Top Mouldings & Rain Gutter - .085 x 7/8" long - pack of 100

Price Pack \$ 1.50

Nail Style #5

Use these where rusting could occur - Stainless Steel .085x 3/4" long - pack 100

Price Pack \$ 3.00

Roof Tacks

This is a set of 100 zinc plated tacks used to tack the black vinyl decking to the wood top frame. The top molding covers these tacks.



A38425MBR

28-31

Price Pack \$ 2.25

WHEELS & PARTS

Specifications:

Material:	Steel
Diameter:	28-29 - 21"; 30-31 - 19"
Rim:	Drop center type; width, 28-29 - 2-3/4"; 30-31 - 3"
Number of spokes:	30 (1/4" diameter)
Nut thread size:	1/2" - 20

*** MIKE'S TIPS ***

Place a thin piece of material or even a piece of tissue paper over the lug nut, before tightening them with your wrench. This will help protect the chrome or stainless steel nuts.

New Wheels

New Model A Wheels finally available after all these years. An excellent reproduction of the original. These are made of a hardened steel and will arrive primed ready to paint or powder coat.



A1015BR	28-29	21"	Price Ea.	\$ 285.00
A1015D	30-31	19"	Price Ea.	\$ 285.00

Early 28 Lug Nuts

Chrome plated. The special locking nut is no longer included.

Set of 23. Torque to 64 Ft. Lbs.

Not always available.

A1012AR	1928	AR only		
---------	------	---------	--	--

Price Set /23 \$ 75.95



28 Style Lug Nut (shorter)

This is the 13/16" hex nut that was briefly used (June thru Sept. '28).

It's cadmium plated and shorter than the AR nut.

Torque to 64 Ft. Lbs.

A1012A	1928		Price Ea.	\$ 2.00
--------	------	--	-----------	---------



Lug Nuts

These are an exact copy of the ones that Ford used. Aug/Sep 28 'til end. You will need 5 per wheel and 3 per spare.

Torque to 64 Ft. Lbs.

A1012B	28-31	Cadmium Plated	Price Ea.	\$ 1.25
A1012C	28-31	Chrome Plated	Price Ea.	\$ 1.30
A1012SS	28-31	Highly Polished-Stainless Steel	Price Ea.	\$ 4.25

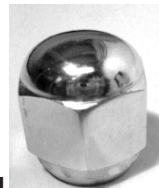

Lug Nut Washers

To correct worn and oversized holes, also protects your paint. You will need 5 per wheel and 3 per spare.



A1012WSS	28-31	Stainless	Price Ea.	\$ 0.45
----------	-------	-----------	-----------	---------

Spoke Cleaning Brush

An excellent quality brush to help keep spokes clean and shiny.

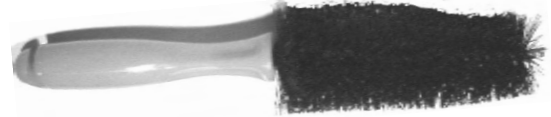

A1017	28-31		Price Ea.	\$ 4.25
-------	-------	--	-----------	---------

Wire Wheel Spoke Straightener

This is an exact copy of the original spoke straightener. Very useful tool to get those bent spokes back into position.



T1018			Price Ea.	\$ 58.95
-------	--	--	-----------	----------

Spoke Covers

Comes with complete instructions.

A long awaited old accessory brought back to finish the look of your Model "A" Wheel.

One set does one wheel.

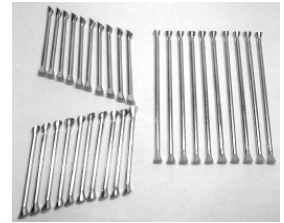

A1519A	19"	1 - 4 Sets	Price Set	\$ 35.00
A1519B		5 or more	Price Set	\$ 31.50
A1521A	21"	1 - 4 Sets	Price Set	\$ 35.00
A1521B		5 or more	Price Set	\$ 31.50

Are you wanting some fancy accessories for your Wheels?? See Page Gen. 16 for Tire Bands, Face Plates and Beauty Rings.

Mike's "A" FORD-ABLE Parts

HUB CAPS

Early 1928 Hub Caps

These are show quality caps made to original specs, including the star Manufacturing symbol. Steel Nickel plated. (Ford Licensed).



A1130AR **Early 1928** **Price Ea.** \$ 23.25

1928 - 1929 Hub Caps

21" Script Centered - Excellent Reproduction Hub Cap for your Early "A".

Official Licensed Product
Ford Motor Company.



2 5/8" Opening in the rim. Nickel was used in all of the '28-'29's. The chrome were used from **April 1929** till the end of 1929.

A1130BN **Nickel** **Price Ea.** \$ 23.25
A1130CH **Chrome** **Price Ea.** \$ 10.40
A1130BC **Stainless** **Price Ea.** \$ 10.40

Hub Cap Tool

Thanks to the unique design of this tool, the hub cap is easily and firmly secured to the wheel, virtually eliminating distracting rattles and lost hub caps caused by poor installation.



T1130 **30-31** **Price Ea.** \$ 57.50

30-31 Stainless Hub Cap

19" wheel. Smooth edge as original with steel liner. Excellent Reproduction. 3 3/4" Opening in the rim.

Official Licensed Product
Ford Motor Company.



A1130SS **1930 - 1931** **Price Ea.** \$ 10.50

Show Quality 30-31 Hub Cap

A show quality version of the **A1130SS** is now available. This hub cap has a domed surface around the word FORD in the center. Reinforced steel liner.



A1130SQ **Mid 1930 - 1931** **Price Ea.** \$ 31.00

V8 and Ford Stainless Hub Cap

If you are running with V8 wheels on your Model "A", here are the caps for you. Available with either Ford Emblem or V8. Stainless Hub Cap that fits wheels with a 5 3/4" opening in the rim.



B1130 **1932 - 1936 Ford Emblem** **Price Ea.** \$ 17.95



B1130V8 **1932 - 1936 V8 Emblem** **Price Ea.** \$ 17.95

TIRES

Specifications:

Size: 28-29, 440/450-21; 30-31, 475/500-19
 Recommended tire pressure: 35 Lbs.
 Station Wagon: 5.00 x 21 or 19, pressure 40 Lbs.
 Tread Width: 21 = 3.75" & 19 = 3.90"

Firestone Tires

4 Ply Polyester -
 Mike has the best price in town, why not give us a call!!! **PLEASE NOTE:** Approx. \$15 - \$20 Shipping charge per tire, certain areas may be more. Whitewalls are 2 5/8" Wide on 21" & 2 3/8" on 19".
These are not a stocked item, but shipped straight from the factory.

Firestone Tread



F4521BW	28-29	440 / 450 - 21	Blackwall 21"	Price Ea.	\$ 113.00
F4521WW	28-29	440 / 450 - 21	Whitewall 21"	Price Ea.	\$ 141.00
F4719BW	30-31	475 / 500 - 19	Blackwall 19"	Price Ea.	\$ 111.00
F4719WW	30-31	475 / 500 - 19	Whitewall 19"	Price Ea.	\$ 141.00

Universal Tires

A great 4 - ply Nylon tire.
 An inexpensive alternative to Firestone Tires.
 Available in Blackwall only.



U4521BW	28-29	440/450 - Blackwall - 21"	Price Ea.	\$ 80.00
U4719BW	30-31	475/500 - Blackwall - 19"	Price Ea.	\$ 80.00

600 x 20 Denman Tire for AA and TT Trucks

This is the same as the 30 x 5 tire. Normally used on the AA and TT Trucks - Blackwall. See **A1025C** for Rim Flaps & **A150620** for tubes.



D6020BW **1919-1931** **Price Ea.** \$ 152.00

Rim Liners

Prevents tube damage. 1 1/2" wide. Fits both 19" and 21".



A1024A **Price Ea.** \$ 2.99

Mike's "A" FORD-ABLE Parts

Rim Flaps

4 Inches of extra wide protection.
Order 19" or 21". 20" Flaps are for the AA Trucks.



A1025AR	19"	30-31	Price Ea.	\$ 17.95
A1025C	20"	AA Truck	Price Ea.	\$ 20.75
A1025B	21"	28-29	Price Ea.	\$ 17.95

Inner Tubes

Rubber stemmed tubes cost less both on the tube and due to the fact that you don't need additional hardware. When ordering Metal Stem tubes, you may need A1500N, A1500W or A1500WW.



A150619	19" Rubber Stem Tube	Price Ea.	\$ 12.95
A150621	21" Rubber Stem Tube	Price Ea.	\$ 13.50
A150619MS	19" Metal Stem Tube - Nickel	Price Ea.	\$ 28.95
A150620	20" Bent Metal Stem Tube - AA Truck	Price Ea.	\$ 29.95
A150621MS	21" Metal Stem Tube - Nickel	Price Ea.	\$ 28.95

Clamp-In Style Valve Stems

Replace your old valve stem with this authentic reproduction. Simply cut off the old stem and clamp this one in. Bridge washer and lock nut provided.

One set does one wheel.



A1500A	28-29	Schrader 6300	Price Set	\$ 16.40
--------	-------	---------------	-----------	----------



A1500B	30-31	Schrader 6700	Price Set	\$ 15.00
--------	-------	---------------	-----------	----------

Authentic Wheel Accessories

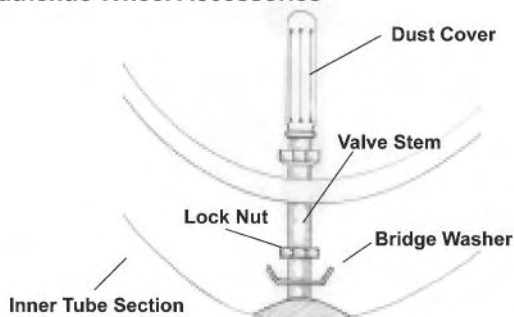

Lock Nut And Bridge Washer

A must for metal stems This nut attaches to the stem on the inside of the wheel to keep the stem from coming out of the tube.



A1500N		Lock Nut	Price Ea.	\$ 1.35
--------	--	----------	-----------	---------

Bridge Washer stabilizes Metal Stem on tube with Lock Nut.



A1500W	28-29	Bridge Washer	Price Ea.	\$ 1.50
--------	-------	---------------	-----------	---------

Bridge Washer stabilizes Metal Stem on tube with Lock Nut.

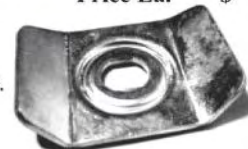

A1501WW	30-31	Bridge Washer	Price Ea.	\$ 1.60
---------	-------	---------------	-----------	---------

'28-'29 Dust Cover/Rim Washer - Long

Close replica of the originals with "Schrader" on the dust cover.



A1500JDS	28-29		Price Ea.	\$ 19.95
----------	-------	--	-----------	----------

'30-'31 Dust Cover/Rim Washer - Short

Close replica of the original with "Schrader" and USA on the base.



A1500C	30-31	Rim Washer	Price Ea.	\$ 7.75
--------	-------	------------	-----------	---------

Original Valve Stem Cap

These original nickel-plated caps are hard to find.



A1500AC	28-29	USA on Top	Price Ea.	\$ 2.85
---------	-------	------------	-----------	---------

A1500BC	30-31	USA on side	Price Ea.	\$ 2.90
---------	-------	-------------	-----------	---------

TIRES

Mike's "A" FORD-ABLE Parts

Tire Irons

All tire irons are tempered for strength.

Blunt on one end. 10" Long.



T17019A **October 1927 - July 1928**
 Price Ea. \$ 18.25

Screw Driver Point on one end. 10" Long.



T17019B **July 1928 - November 1928**
 Price Ea. \$ 18.25

Spoon on one end. 10" Long.



T17019C **December 1928 - End**
 Price Ea. \$ 17.15

Twist Style, Screw driver point on one end.
 19 3/4" Long.



T17019D **Late 1931** Price Ea. \$ 20.15

Crank

This dual purpose tool can use one end to crank your car and the other to remove lug nuts.

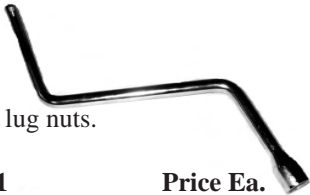

T17036 **28-31** Price Ea. \$ 11.95

Tool Bag

This is a nice heavy duty tool bag to keep your tools clean and together. Cobra style top material.

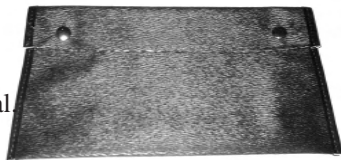

T17005 **28-31** Price Ea. \$ 8.95

Tire Pump

This is a good copy of the later style stamped steel base pump. It is fitted with the correct hose, clamps and brass ends.



A1501 **28-31** Price Ea. \$ 121.00

Tire Pump Hose

Replace your old, cracked hose with this cloth covered hose. Not totally original.

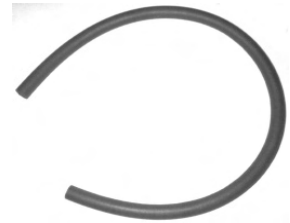

A1501H **28-31**
 Price Ea. \$ 4.65

Tire Pump End Clips

A pair of original type hose clips.



A1501CL **28-31** Price Pair \$ 1.95

Tire Pump Hose Repair Kit

A pair of hose clips and the hose end that attaches to the inner tube. Correct Size.



A1502 **28-31** Price Set/3 \$ 6.50

Tire Gauge Stem Tool

This is a brass, chrome plated tool. Has a female thread.



T18100S Price Ea. \$ 16.30

Tire Gauge Lens

If your glass lens is cloudy or broken, replace it with this new glass lens.

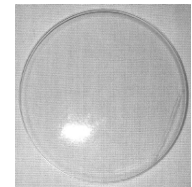

A18100L **28-31** Price Ea. \$ 5.50

Tire Gauge Face Plate

Replace the face plate on your old model A tire gauge with this full color repro.



A18100FP **Official Licensed Product**
Ford Motor Company
 Price Ea. \$ 5.95

Tire Gauge

A fairly close reproduction of the original Model A tire gauge, but not exact. The gauge has a brass stem and aluminum housing.



A18413 **28-31** Price Ea. \$ 29.00

TIRES

Mike's "A" FORD-ABLE Parts

SPARE TIRE

Rear Spare Tire Blank Off Kit

Use these when you don't have a rear tire mount. 2 large for sill, and 1 snap-in plug. Paint body color. Upper plug won't fit Town Sedan.

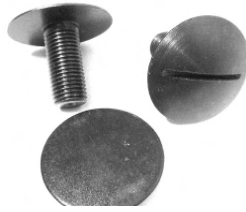

A1449CO 28-31 Price Set/3 \$ 5.95

Spare Tire Covers

Draw string for snug fit, naugahyde for easy cleaning, Ford Script.



A1395B21	28-29	21" Black	Price Ea.	\$ 28.95
A1395T21	28-29	21" Tan	Price Ea.	\$ 28.95
A1395B19	30-31	19" Black	Price Ea.	\$ 28.95
A1395T19	30-31	19" Tan	Price Ea.	\$ 8.95

Spare Wheel Fender Wells

Good heavy steel, these are wells that are welded into fender.

7 1/4" wide
30x 31



6 1/2" wide
28x29



A16029	28-29		Price Ea.	\$ 33.95
A16031	30-31		Price Ea.	\$ 31.95

Side Mounted Spare Tire Carrier and Plate

Used right or left side. Original style with frame plate. Use same brackets Right and Left, on '28-'29 only. Plates Included. 2 Piece Set.

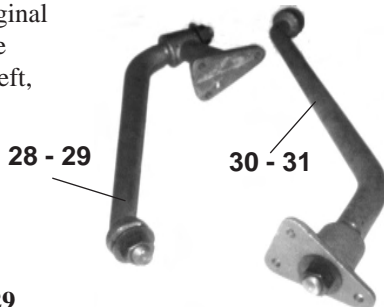

A1405AR	28-29		Price Set/2	\$ 34.95
A1406A	30-31	Driver Side	Price Set/2	\$ 34.95
A1406B	30-31	Passenger side	Price Set/2	\$ 34.95

Spare Tire Plates Only

When you have the arm, we have the plate.....

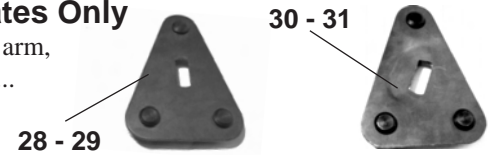

A1406APL	28-29		Price Ea.	\$ 12.95
A1406BL	30-31	Driver - Left	Price Ea.	\$ 12.95
A1406BR	30-31	Passenger - Right	Price Ea.	\$ 12.95

Spare Wheel Side Mount Hardware

These are included when you purchase A1405AR, A1405A or B. 2 x 5/8 - 18 Nuts, 2 Cotter Pins & 1 Flat washer. Cotter Pins are only used on Original Arms.



A1405X	28-31	Price Set/5	\$ 2.50
--------	-------	-------------	---------

Spare Wheel Side Mount Bracket Bolts

A set of 3 drilled bolts and 3 castle nuts to mount spare tire bracket to frame. 3 x 5/16 - 24 x 1" Cross drilled bolts & 3 castle nuts.



A1405MB	28-31	Price Set/6	\$ 3.15
---------	-------	-------------	---------

Spare Wheel Side Mount Bracket Rivets

Set of 3 rivets. Rivets were originally used, but now commonly replaced by A1405MB. Rivets still available.



RA1004	30-31	Price Set/3	\$ 1.50
--------	-------	-------------	---------

Spare Wheel Side Mount Grommet

Place in splash shield to fill hole between spare tire and shield. Grommet is not painted.



A1410G	28-34	Price Ea.	\$ 1.35
--------	-------	-----------	---------

Rear Spare Wheel Tire Carrier Bolt

You'll need 3, original square shouldered bolts. Used also on rear mount spare tire carriers. Two top bolts only.



A1448	28-31	Price Ea.	\$ 1.80
-------	-------	-----------	---------

Rear Spare Wheel Tire Stud

Used for Coupes, Roadsters, bottom stud only, the top two are the A1448 bolt.



A1449	28-31	Price Ea.	\$ 1.65
-------	-------	-----------	---------

Mike's "A" FORD-ABLE Parts

Spare Tire D-Nut

Used in the rear of body where the spare was mounted, special bolts and plug, 2 required.



3/8 x 24 any year 3/8 - 24
Price Ea. \$ 1.35

Rear Spare Tire Bracket Jam Nut

This thin jam nut goes over the spare mount stud to adjust the angle of the tire. Thin - 1/2"-20.

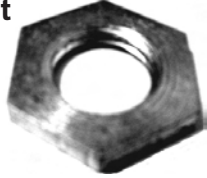

A1450J 28-31 Price Each \$ 0.95

Spare Tire Band Lock Nut

This special lug nut was used on the rear wheel spare lock band. The lock is no longer available.



A1451TBN 28-31 Price Ea. \$ 3.95

Are you wanting some fancy accessories for your spare Tire?? See Page Gen. 16 for Tire Bands, Face Plates, Beauty Rings and Spoke Covers.

Order Online Now and Save 5%

Visit our website for all your Model "A" needs.



www.mikes-afordable.com

SPARE TIRE

HUBS

Front Hub Bolts

These have to be swaged in on a 30 - 40 ton Has a longer shoulder for repro. Drums. You will need 5 per wheel. If you wish to use these studs on old steel drums, 1/16" must be machined off of the shoulder.



See tip on Page Gen. 42.

A1107 **28-32** **1/2" - 20 Threaded**
Price Ea. \$ 0.75

Front Hub

This quality reproduction of the front wheel hub fits all A's.

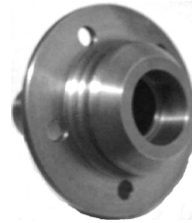

A1105 **28-31** **Price Ea. \$ 179.00**

Front Hub / Drum Assembly

Hub has been swaged onto drum and turned true. **Races are included.**



FOR DRUMS ONLY SEE PAGE GEN. 45.
FOR COMPLETE FRONT BACKING PLATE SETUP SEE PAGE GEN. 45.

NEW Hub, and New Cast Iron Drum, Swaged & Turned to fit shoes, Inner Races Installed.
A1106FN **28-31** **New Hub Price Ea. \$ 315.00**

Customers **GOOD USED** Hub, New Cast Iron Drum, Swaged & Turned to fit shoes, Inner Races Installed.
A1106FCU **28-31** **Good Used Hub Price Ea. \$ 189.00**

GOOD USED Hub Supplied by Mike's, New Cast Iron Drum, Swaged & Turned to fit shoes, Inner Races Installed.
A1106FMU **28-31** **Mike's Original Used Hub Price Ea. \$ 219.00**

Front Hub Nuts

The front hub held onto the spindle by these castle nuts. 3/4"-16. Order cotter pin #37 or #37SS separately. Need 2 per car. See Page Gen. 34.



A1193 **28-31** **Price Each \$ 1.25**

Dust (grease) Caps - Drive-in Style

Retains grease, and keeps dirt out of front hubs. Some grinding of the washers **A1195** - Approx. 1/64" off the OD - before using the caps. These caps were not originally supplied by Ford.



A1138 **28-31** **Need 2** **Price Ea. \$ 2.25**

Front Hub Inner Dust & Grease Seal

You'll need 2 per car, metal drive-in seal located at base of spindle, keeps grease away from brake area.



USA Made for perfect fit Correct ID **1.621/1.624** & OD is **2.485/2.490**

A1190 **28-34** **Price Ea. \$ 1.90**

A1190USA **28-34** **Price Ea. \$ 4.50**

Front Hub Grease Retaining Washer

This retainer fits between the front wheel bearing and axle nut.



A1195 **28-48** **Need 2** **Price Ea. \$ 1.10**

Front Wheel Bearings

Timken supplied whenever possible. 2 of each needed for 1 car. Best results had by replacing both bearing and the race.



A1201 **28-48** **Inner Bearing Price Ea. \$ 11.75**



A1202 **28-48** **Inner Race Price Ea. \$ 7.50**



A1216 **28-48** **Outer Bearing Price Ea. \$ 11.65**



A1217 **28-48** **Outer Race Price Ea. \$ 5.60**

Mike's "A" FORD-ABLE Parts

***** MIKE'S TIPS *****

Always make sure that your front hubs fit securely onto your wheel bearings. To remove any excess play, remove the wheel and tighten the spindle nut until the hub begins to bind. Then back off the nut until the binding stops and insert the cotter pin.

Hub Stud Installation Swage

A 30 - 40 ton hydraulic press must be used with this tool to install hub bolts. This is known as swaging.



T1109T 28-31 Price Ea. \$ 9.95

Wheel Bearing Grease

Ideal for packing bearings.



A1220 16 ounces Price Ea. \$ 6.60

Rear Hub Bolts

These have to be swaged in on a 30 - 40 ton press. Has a longer shoulder for repro. Drums. You will need 5 per wheel. If you wish to use these studs on old steel drums, 1/16" must be machined off of the shoulder.

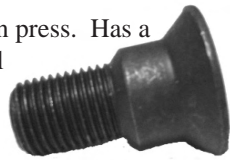

A1118 28-32 1/2" - 20 Threaded Price Ea. \$ 0.80

***** MIKE'S TIPS *****

When you are about to install new hub bolts - I suggest you use the service of a quality Machine Shop .

These bolts are to be swaged under at least 30 - 40 tons of pressure - this is critical and should be done by an expert (let Mike's help you).

Rear Hub

This quality reproduction of the rear wheel hub fits all A's.

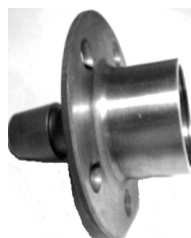

A1115 28-31 Price Ea. \$ 185.00

Rear Hub / Drum Assembly

Hub has been swaged onto drum and turned true.

Bearings are not Included.



FOR DRUMS ONLY SEE PAGE GEN. 45.

FOR COMPLETE REAR BACKING PLATE SETUP SEE Page Gen. 45.

NEW Hub, and New Cast Iron Drum, Swaged, both Service and Emergency Brake surface turned to fit shoes. **Bearings are NOT included.**

A1116RN 28-31 New Hub Price Ea. \$325.00

Customers **GOOD USED** Hub, New Cast Iron Drum, Swaged, both Service and Emergency Brake surface turned to fit shoes.

Bearings are NOT included.

A1116RCU 28-31 Good Used Hub Price Ea. \$ 189.00

GOOD USED Hub Supplied by Mike's, New Cast Iron Drum, Swaged, both Service and Emergency Brake surface turned to fit shoes. **Bearings are NOT Included.**

A1116RMU 28-31 Mike's Original Used Hub Price Ea. \$ 219.00

Rear Hub Puller

No more hard pulling! This pulls the rear hubs free from the axle.

An exact copy of the K. R. Wilson Tool.

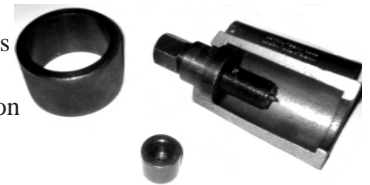

T1114T 28-48 Price Ea. \$ 144.95

Rear Hub Puller

An Economy style Hub Puller to do the job for you. Made from strong ductile Iron.



T4239A 1928 - Protruding Price Ea. \$ 33.00

Shown on Hub

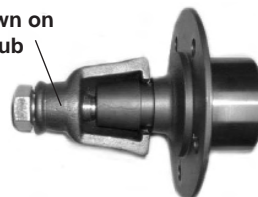

T4239B 29 - 32 - Recessed Price Ea. \$ 33.00

HUBS

Mike's "A" FORD-ABLE Parts

Rear Hub Repair Kit

Great little helper!!!! Contains 1 sleeve, 1 bearing, same I.D. As original bearing, a little smaller O.D. Use if bearing is pitted or shows wear. 2 Pce Set

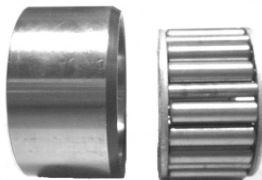

A1115RK 28-31 Price Set/2 \$ 66.00

Installation of Hub Repair Kit

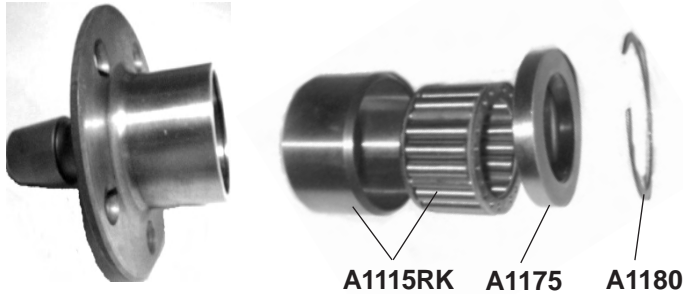

Rear Wheel Bearing

Large roller bearing that rides in the rear hub. Need 1 for each rear wheel.



A1225A 28-36 Price Ea. \$ 24.95

Housing Race Repair Kit

Turn old axle race to .0005 larger than inside diameter of the new race for a press fit.



A1225SL 28-31 Price Ea. \$ 23.75

***** MIKE'S TIPS *****

Thoroughly check your bearings for cracks, scores or pits. Clean them in a solvent such as Kerosene. I advise to always replace bearings as they are usually old or worn out - rather play it safe - especially if you drive your "A" on Tours. Use a good grade of grease, and never be afraid to use too much.

Rear Wheel Hub Grease Seal

You'll need 2, 1 in each rear hub: neoprene seal prevents grease from entering brake area.



A1175 28-38 Need 2 Price Ea. \$ 4.00

***** MIKE'S TIPS *****

Any leather or Neoprene Grease Seals should be coated with grease before being installed. This lubricates the seal so it will seal better.

Rear Wheel Snap Ring

This little ring snaps in to hold the grease seal and bearing in place on the hub, you'll need 1 in each rear hub. This also fits into some transmissions.



A1180 28-38 Need 2 Price Ea. \$ 1.45

Do you need a
Discount on your
parts?

Order online at
www.mikes-afordable.com
and save 5%!!

BRAKES

Specifications:

% of braking power:	front, 40%; rear, 60%
Diameter of drums:	11" + or - .010"
Drum width:	1-3/4"
Length of brake shoes:	14"
Brake shoe lining thickness:	3/16"
Brake shoe lining material:	woven wire and asbestos composition
Total brake shoe surface area:	168 sq. In.
Brake rod length:	51-7/16" to 51-1/2"

***** MIKE'S TIPS *****

When Mechanical Brakes are installed and adjusted correctly - they will perform as well as hydraulic brakes. Make frequent adjustments to your brakes. Why don't you let Mike's arc your Brake Shoes to fit your drums.

1. First and foremost, do everything possible to take out all the slop in the system.
 - A. There are no shortcuts to getting good brakes. If you use halfway restoration procedures, you will get half the brakes you want.
 - B. Also, make sure your front axle radius rod is tight in its socket. In many cases they loosen and move to the rear when the brakes are put on. This is just more slop that needs to be taken out.
 - C. Use the all steel radius rod ball socket setup. Junk the rubber ball after market one.
2. Rebush brake & clutch pedals and replace worn pedal shaft. I use an additional trick to make braking easier by shortening the "throw" of the brake pedal arm. To use this, you must have an excellent brake system.
3. Holes in operating levers and brake rods / clevis' should be 5/16". If not, rebush and ream. An alternative is to bore them out to 11/32" and use oversize brake rod pins (11/32"). Bear in mind they are usually worn off center and the drill will follow the hole and it will end up more off center.
4. Brake backing plate roller pin tracks should be built up to hold shoes on center. If roller pins or rollers have flat spots, replace them. Get machined pins, not stamped out ones.
5. Brake shoe adjusting wedges should be equal length on each pair of shoes.
6. Brake wedges and cams should have wear spots leveled up to make for ease of action. Be careful of some repro. Cams - the angle of the action is sometimes wrong. Mike's cams are the correct angle.
7. Bushings in the rear backing plates and parking brake carriers should be replaced and reamed to fit new cam shafts and rebuilt operating levers.
8. Front brake actuating arm should be built up and housing rebushed, if needed.
9. Front operating pins should be built up about 1/8" to 1/4" to

insure front lever leans forward at least 15 Deg. When brakes are properly adjusted. Pills can be used, but this is second best.

10. Main service brake cross shafts should be built up if worn badly, turned down to 13/16" and new bushings fitted. Operating lever pin holes should be rebushed if worn excessively. Exchange your worn one at Mike's.

11. Brake drums, pressed type, should not be turned down ...

- A. Henry Ford didn't intend them to be. Quote from Page 514 of the Service Bulletins: "*Under no circumstances must any attempt be made to turn down brake drums on A cars and AA trucks. The brake drums we supply have a rolled braking surface to lessen any possibility of scoring and it is very essential that this surface not be touched with any kind of machining tool*". Cost of drum and hub assembly in 1928 - front - \$4.50 and rear \$5.50.

- B. Thin drums get hot and out of round. Won't stop.
- C. If you are a diehard and insist on having your drums turned down, they should *never* be over .100" above 11 inches.

12. Cast Iron drums should be used if there is any doubt.

- A. They are made undersize and will have to be turned and ground once mounted on old hubs to fit new shoes and to renew the center. This is one of Mike's specialties.

- B. Parking brake step should be turned out about .035 - .040" to allow for ease of fit for parking brake band.

- C. To remove drums, first cut out old swaging of lug bolts and then carefully knock out the lug bolts to avoid warping hub flange.

- D. Order drums, hubs, and new lug bolts, and shoes from Mike's for swaging of lug bolts, turning of drums, and lining and arching of shoes.

13. After all restoration and painting is done, assemble brake shoes to backing plates. Use a centering check gauge to see if shoes are in the center of the action.

14. Assemble hubs and drums to Front spindles and Rear Axles.

- A. Adjust front spindle bearings. Don't overtighten. Look for worn spindles and looseness.

- B. Use a new axle key, axle gasket washer, heavy flat washer, and castle nut to secure rear hub. If drums tends to rub on backing plate, use one or two axle shims. Don't be afraid to tighten the rear axle nut tightly - Torque 105 Ft. Lbs.

15. Adjust all 4 sets of brake shoes by tightening until drum won't turn. Back off until a touch of a drag is present. Don't be overly alarmed if there's a high spot. It is not wanted, but not a tragedy.

16. After adjusting shoes, adjust rear brake rods first.

- A. Brake pedal should be all the way back and cross shaft arms should be vertical. If not, adjust clevis on main brake rod at pedal.

- B. Pull each brake rod forward until drum locks up, then back off until drum will turn. Adjust clevis eyes and insert brake rod pins. Tighten jam until clevis should be at brake cross shaft.

17. Adjust front brake rods the same way. Clevis should be at the front operating lever. Tighten jam nut.

18. Use a notched board to test brakes.

- A. 1" - Rear brakes should drag hard and even from side to side, front turn easily.

- B. 1 1/2" - Rear brakes should lock, front drag hard, evenly from side to side.

- C. 2" - Front and Rear brakes locked.

19. Run a few hundred miles, until you get them broken in and set properly. Run the same shoe and rod adjustment procedure as above.

20. Adjust parking brake rods. Pull on rod until drum locks down,

Mike's "A" FORD-ABLE Parts

back off a little and adjust clevis. Tighten jam nut. Note: This is for *parking* brake and not *emergency* brake. If you try to use parking brake to stop, you'll probably damage something. If your service brakes are properly restored, you'll *never* need an "Emergency" brake.

The following new parts are required to complete a restoration of your Service and Parking Brake. This is only a guide - do not assume that this is all that is needed, all other parts need to be thoroughly checked and rebuilt if necessary. If rebuilding is something that you do not wish to do, all of the original parts can be rebuilt at Mike's "A" Ford-able Parts.

1. Front **A2011A** or Rear **A2011BR** Track Assembly
2. Brake Riveting Tool - **T2018**
3. Service Brake Lining - **A2021**
4. Brake Shoe Rollers - **A2023**
5. Brake Shoe Roller Pins - **A2045**
6. Brake Shoe Adjustment Shaft Pins - **A2027**
7. Brake Return Springs - **A2035/36**
8. Lever Pins - **A2085**
9. Dust Rings for Front and Rear Brake Shaft - **A2087S**
10. Front Brake Shaft, and Rear Toggle lever Bushings - **A2227**
11. Rear Camshaft and Actuating Lever Arm Bushing Tool - **T2227R or T2227AR**
12. Rear Brake Cam - **A2230**
13. Rear Brake Cam Shaft - **A2231**
14. Camshaft Lever Pins - **A2238**
15. Brake Rod Clevis Pins - **A2462 or A2463**
16. Service and Emergency Brake Rods - **A2499/B2864**
17. Centre Service Brake Cross Shaft Bushings - **A2477 or A2477BS**
18. Cross Shaft Rivets - **A2485RI**
19. Emergency Brake Shoe Toggle Lever Pins - **A2633S**
20. Emergency Brake Linings - **A2620**
21. Emergency Brake Lever Mounting Set - **A2644S**
22. Emergency Brake Lever Springs - **A2646/47**
23. Brake Rod Anti - Rattle Springs - **A2504/2866 or A2504/2866B & Nuts - A2504MB**

1928 AR Brake Drums

Used only on the very early cars. Both front and rear are the same.



A1125AR 1928 AR Price Ea. \$ 129.95

Brake Drums

If your drums have been turned too much, replace them with these cast iron reproductions. When purchasing new drums, please think of your safety. We sell the USA Quality which have been on the market for years. No Extra Machining Required.

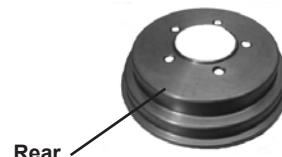
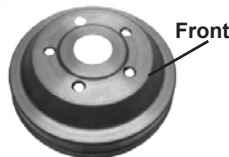

A1125	28-31	Front - Made in USA	Price Ea.	\$ 105.00
A1126	28-31	Rear - Made in USA	Price Ea.	\$ 110.00

FOR HUB BOLTS & TIPS SEE PAGE Gen. 41 & Gen. 42.

Mike's also has complete Brake Drum and Hub Assemblies, using either new or reconditioned hubs - see Page Gen. 41 & Gen. 42.

The inside diameter of the Service Brake Drum is 11" plus or minus .005. The emergency inside diameter is 9.620 to 9.630.

Complete Front & Rear Backing Plate Systems

Send in your Backing Plates, Emergency Backing Plates, Oil Baffle Plates and shoes. We will restore your Backing plates, Sand Blast and Powder Coat them. Rebuild the Roller Tracks, install New Brake Linings on your shoes - Arc shoes to fit drums - all other parts installed will be new, unless not available. Returned ready to install.

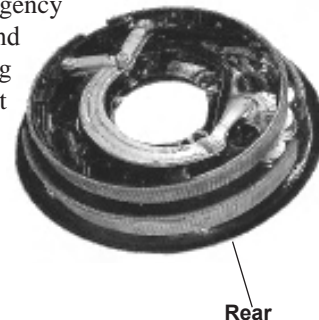

No Painting Needed!!!!

This includes A2011MB - Front Backing Plate Bolt Set				
A2000	28-31	Front Backing Plate System	Price Ea.	\$ 195.00

This includes A2248/50 - Backing Plate Mounting Bolts				
A2200	28-31	Rear Backing Plate System	Price Ea.	\$ 225.00

Order A1175 - Seals, A1180 - Snap Rings & A1225 Bearings Separately.

Mike's "A" FORD-ABLE Parts

Brake Drum Reinforcing Bands

Extend the life of your original drums and your own safety with these reinforcing bands. Instructions for mounting included.



A1125B 28-31 Price Ea. \$ 26.75

Front Brake Track Assembly

Install a new set on your worn tracks. Kit includes 2 roller tracks, 4 rivets and rivet tool to rebuild both front wheels. Instructions included.



Heat treated. Tool Included.

A2011A 28-31 Price Set/7 \$ 34.10

Rear Brake Track Assembly

Replace your worn rear tracks on both wheels with this set. Includes instructions and all the parts necessary & Tool.



A2011BR 28-34 Price Set/17 \$ 85.00

Front Brake Backing Plate Bolt Set

These old-style bolts have the shank drilled for cotter pins. Full set does 2 wheels. The Nuts face outside of the Backing Plate.

8-3/8"-24 x 13/16" Bolts, Castle Nuts.



A2011MB 28-34 Full Set Price Set/16 \$ 10.25

Front Backing Plate (Rebuilt)

Send your Backing Plate in to us and we will rebuild it for you. It will be sand blasted and powder coated (black). Restored Roller Track and New Adjusting Wedge will be installed. This is **NOT** a re-manufactured item, **your** backing plate will be reconditioned. **EXCHANGE ONLY.**

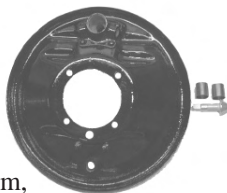

A2011RB 28-31 Price Ea. \$ 80.00

Brake Track Mount Set

Long enough for front or rear brake tracks. Must be heated red hot to install.

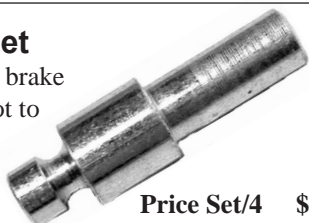

A2013 28-31 Price Set/4 \$ 3.25

Track Rivet Tool

Use this tool to keep from damaging the heads on the A2013 Rivets, by placing them in the center, and using it as a Bucking Bar when peening.



T2013T 28-31 Price Ea \$ 1.50

***** MIKE'S TIPS *****

If you should choose to install the linings on your brake shoes yourself, make sure that the lining is clamped tightly onto your shoe. Start with the two center holes and work outwards towards each end. To complete the project, grind the outer ends of the lining at an angle to the two end rivets.

Service Brake Lining

Replace your brake linings with this complete set of 8 linings. Soft woven fiber with no asbestos. Set of 80 rivets.



A2021 28-31 Price Set \$ 69.95
A2021H Half Set Price Set \$ 36.95

Relined Shoes

Let Mike reline your shoes; original shoes will be sandblasted, painted black, and have new lining (A2021) installed. **Exchange Only.** We must have your old shoes before sending ours.



A2021RE Exchange - Labor charge Only Price Ea. \$ 7.00

(Don't forget to Include the Service Brake Linings A2021 for a full Set of A2021H for a Half Set in your calculations.)

A2021REC REFUNDABLE CORE Price Ea. \$ 5.00

A2021RO Outright Price Ea. \$ 21.00
(Cost for one Service Brake Lining Only is \$8.00)

Brake Riveting Tool Set

This is an invaluable tool for the DIYer. It comes complete with a punch to remove old rivets, a tool to drill and countersink lining, and a tool to install new rivets.



T2018 28-31 Price Set/5 \$ 27.50

Replacement Riveting Tools for the T2018

Hardened heat treated replacement tools for the T2018 Set.



T2019 28-31 Price Set/4 \$ 9.00

Brake Lining Tube Rivets

80 rivets included for installing your service brake linings. Also used for Emergency Linings.

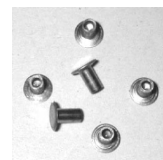

A2018R 1 set pack Price Set/80 \$ 2.95

Mike's "A" FORD-ABLE Parts

Brake Shoe Rollers

This cadmium plated roller has been heat treated. Discard old rollers if they are not perfectly round.



A2023 28-34 16 needed
Price Ea. \$ 0.85

Brake Adjusting Shaft Pins

This is a quality cadmium plated pin. These pins go at the end of the shoe to secure A2042 that rests against A2041. Need 8.



A2027 28-32 Price Ea. \$ 0.40

Long Brake Adjusting Springs

You need one of these long adjusting springs per wheel.



A2035 28-31 Price Ea. \$ 1.75

Short Brake Adjusting Spring

You need two short springs per wheel.



A2036 28-31 Price Ea. \$ 0.85

Brake Spring Set

A best buy. A complete set of brake springs for your A. Set includes 4 emergency brake springs, 4 long & 8 short adjusting brake springs.



A2035/36 28-31 Price Set/16 \$ 14.50

Brake Adjustment Wedge

This wedge goes through the backing plate so you can adjust the brakes. Need one per wheel.

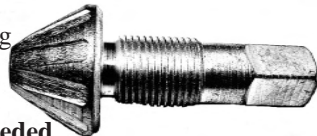

A2041 28-34 4 Needed
Price Ea. \$ 8.45

Brake Adjustment Wedge Tool

Used on the wedge when adjusting your brakes.



T2041T 28-34 Price Ea. \$ 8.75

Brake Adjusting Tool

A very handy tool to adjust your brakes by pushing the brake pedal down to a specific distance so you can adjust each wheel. The brakes are adjusted at the wheels in relation to how far the brake pedal is depressed. The top of the tool hooks around the steering wheel.

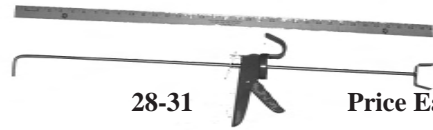

T2012 28-31 Price Ea. \$ 27.95

Brake Dust Caps

These excellent reproductions are needed when you replace the adjustment wedge. Turn the wedge clockwise in its housing until loose, then tap the square end. The cap will pop off the end and the wedge can be removed.



A2041C 28-31 4 needed Price Ea. \$ 1.25

Brake Adjusting Shaft

These enter into the brake adjusting housing to expand the brake shoe. Sold in matching pairs ONLY. Need 4 Pairs.

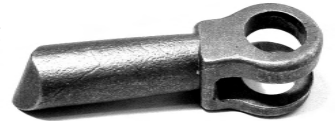

A2042 28-34 Price Pair \$ 4.95

Brake Shoe Roller Pins

These zinc plated, hardened pins attach to the bottom of the brake shoes. Two per wheel needed. Correct head.

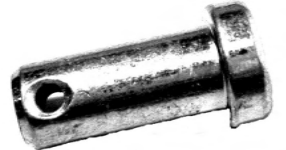

A2045 28-31 Price Ea. \$ 0.40

Front Brake Operating Wedge

This wedge activates the front brakes when the operating pin pushes against it. Best Quality - correct angle.



A2050 28-34 2 Needed Price Ea. \$ 15.75

Front Brake Operating Wedge Stud

This bolt holds the front brake wedge assembly in place at the bottom of the front backing plate. Includes washer A2052. 2 Sets Needed.



A2051 28-31 Price Set \$ 6.75

Front Brake Floater Kit

This easy to install kit allows brake shoes to "float" or "equalize" when the brakes are applied. 2 Front Brake Wedge Studs, Castle Nuts, Cotter pins & Floater Pins and Stud Washers. One set needed per car.



A2051FL 28-31 Price Set/10 \$ 21.95

BRAKES

Mike's "A" FORD-ABLE Parts

Front Brake Operating Wedge Stud Washer

This special washer goes onto the **A2051** wedge stud after the stud is in place and before the castle nuts. Need 1 for each front brake. Included in **A2051**.



A2052 28-34 Price Ea. \$ 1.25

Front Brake Operating Wedge Stud Mount Set

This set consists of 2 castle nuts to hold the wedge stud in place.

One set does both brakes. Order **#37** or **#37SS** for cotter pins. 1/2"-20.



A2051MB 28-34 Price Set/4 \$ 1.50

Flat Head Ted Dead Stop Brake Energizer Kit STOP WITHOUT THE USE OF HYDRAULICS!!

This product is made to fit Models A, B, 1933, 1934 & 1935 Ford V8's. The manufacturer has been over a year developing and fine-tuning this brake system resulting in vast improvements in braking ability for the cars it has been fitted to. This product gives a true full floating 100% servo action, unlike other products on the market that will give you 50%. If you are thinking of later hydraulic brakes or Lincoln backing plates on your Model A, Rat Rod or early V8, this is the product for you! This product is more affordable than hydraulic brake conversions and is high quality with hardened components. You will be surprised how well these kits work!

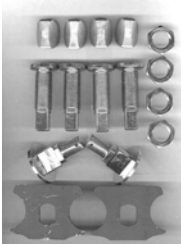

M1008 28-31 Price Set \$ 135.00

Front Brake Operating Pin

This pin runs from the brake actuating arm, through the king pin to the front brake wedge, to activate the brakes. Need 1 per side. 7 5/16" long.



A2075 28-31 Price Ea. \$ 2.10

Front Brake Grease Baffle

A new item, made from original Ford Blueprints. Critical to keep grease off of brake linings, bolts directly onto the backing plate. 2 Needed - one per wheel.



M1001 28-31 Price Ea. \$ 24.95

Front Brake Operating Pin Shims

Use these shims to put off a complete brake job by taking up the slack on the operating pin and other components. You may need 2 or 3 per wheel.



A2075SH 28-31 Price Pair \$ 0.95

Front Brake Lever Operating Shaft Nuts

Holds shaft to the spring perch. Order Cotter pin **#37** or **#37SS** for **A2078A**.

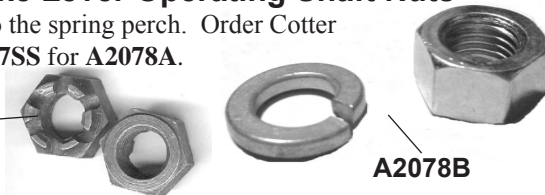

A2078A 28-29 2 x 7/16-20 Cad Castle Nut Price Pair \$ 0.60

A2078B 30-31 2 x 7/16-20 Hex Nut & washer Paint black Price Set/4 \$ 0.70

New Front Brake Operating Shaft

This shaft goes into the actuating shaft housing - **A2078X**. Pin Included.



A2076BR 28-33 Right Price Ea. \$ 23.00
A2076BL 28-33 Left Price Ea. \$ 23.00

Rebuilt Front Brake Actuating Shaft

Send in your complete actuating arms for us to rebuild. We will remove the old bushings, sand blast the arm, install and ream new bushings, reassembled with new dust ring and old arm repinned.

If new shafts are needed - add **A2076BR** or **BL**.



A2078X 28-31 Price Ea. \$ 48.50

Front Brake Lever

This lever is pinned to the **A2076BR** or **BL** (New front brake operating Shaft). The service brake rod clevis rests in the yoke. Left and right are all the same.



A2084 28-33 Price Ea. \$ 11.50

Front Brake Shaft Bushings for Actuating Arms

You will need 4 of these graphite coated bushings for your front brake shafts. Ream to .562 or 9/16".



A2082 28-31 Price Ea. \$ 0.55

BRAKES

Mike's "A" FORD-ABLE Parts

Front Brake Lever Shaft Bushing Reamer

13" Long fluted .559 reamer to reach both bushings. See Mike's Tips below.



T2082R 28-36 Price Ea. \$ 117.50

Universal Bushing Installation & Removal Tool

An ideal Tool to remove bushings from Rear Brake Camshaft, Rear & Front Spring and Perch Bushings.



T3820/44T 28-31 Price Ea. \$ 10.95

**** MIKE'S TIPS ****

Always turn reamers clockwise, even when removing from the hole. Never turn counter clockwise, it will dull the blades. Use reamer oil for reaming steel or Kerosene for brass or soft metals.

Front Brake Lever Shaft Pins

These pins hold the lever that the brake rods connect to.

Heat Red hot and Peen.

1/4" x 1" Flat Head

A2085 28-31 Price Pair. \$ 0.95



Front & Rear Brake Dust Rings

This set is critical to keep dirt and grime out of the brake bushings. They fit over the shaft of the brake camshafts before the levers are slipped on. Smaller rings go on the front. One set needed per car.



A2087S 28-31 Price Set/4 \$ 1.25

Rear Brake Camshaft Lever Pins

These 2 pins hold the rear brake levers onto the brake camshaft.

2 x 1/4 x 1 3/8" Pins -

heat red hot and peen.

A2238 28-31 Price Pair \$ 0.75



Rear Brake Camshaft Bushings

These bushings are for both the service and the emergency brake shafts. Ream to .688.

Need 8.

#521 Bronze.

A2227 28-34 Price Set/8 \$ 4.55

A2227A 28-34 Price Ea. \$ 0.60



Rear Brake Camshaft and Emergency Toggle Lever Reamer - Import

An adjustable Reamer for the Rear Brake Camshaft Bushings (A2227) and also the Emergency Toggle Lever Bushings. Reams to .688. Read Mike's Tips on this page.



T2227AR 28-34 Price Ea. \$ 27.95

Rear Brake Camshaft and Emergency Toggle Lever Reamer - USA

A quality Spiral Hand reamer, reams the Rear Brake Camshaft Bushings (A2227). This is a fluted reamer - 5" long to reach both bushings in one operation. Ream to .688. Read Mike's Tips on this page.



T2227R 28-31 Price Ea. \$ 56.95

Rear Brake Camshaft

Used to spread the rear brake shoes apart, using the cam (A2230).

Cadmium plated and hardened.

Two sizes were used in 1928 to June 1928 when there was no Emergency Brake.

2 Needed per car.

A2231AR 1928 2 7/8" Long, 1 1/8" diameter
with .623 cam Hole
Price Ea. \$ 11.50

A2231AS 1928 2 7/8" Long, 1 3/16" diameter
with .750 cam hole
Price Ea. \$ 11.50

A2231A June 28-34 3 7/8" Long.
Price Ea. \$ 9.25



Rear Brake Cam

Good quality = Good value.

Correct shape. Hardened and Plated.

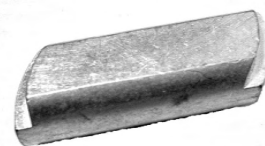

A2230 28-34 2 Needed Price Ea. \$ 6.25

Rear Brake Grease Baffle

Critical to keep grease off your rear brake linings. Fits into the emergency backing plate.

2 Needed - One per wheel.



A2240B 28-31 Price Ea. \$ 7.50

Mike's "A" FORD-ABLE Parts

Rear Brake Backing Plate Mount Bolts

These cadmium plated nuts and bolts attach the rear backing plates and the radius rod to the axle housing.

Nuts to inside of drum.



A2248 28-31 Long housing bolt - Need 4
7/16"-20 x 1 7/8"
Price Ea. \$ 1.85



A2249 28-31 short housing bolt - Need 4
7/16"-20 x 1 17/32"
Price Ea. \$ 1.45



A2250 28-31 housing bolt nuts - Need 8
Price Ea. \$ 1.85

This set has the hardware for one wheel - 2 long bolts, 2 short bolts, 4 nuts, and 4 cotter pins. Need 2 sets per car.

A2248/50 28-31 Price Set/12 \$ 12.00

Rear Service Brake Camshaft Levers

Made from Ford Blueprints. These are pinned to the brake cam shaft - the service brake is secured to the fork using a clevis pin - A2462.



A2235C 28-31 Right Price Ea. \$ 14.95
A2236C 28-31 Left Price Ea. \$ 14.95

Rebuilt Rear Backing Plate

Send your Backing Plate in to us and we will rebuild it for you. It will be Sand Blasted and Powder Coated (Black). New Roller Track, Adjusting Wedge, Dust Cap, Cam, Camshaft Bushings and Lever is installed. This is **NOT** a re-manufactured item, your backing plate will be reconditioned. **EXCHANGE ONLY.**

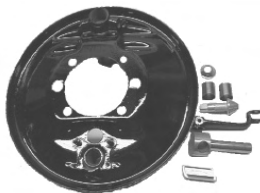

A2211RBL Left Price Ea. \$ 125.00
A2211RBR Right Price Ea. \$ 125.00

Brake Pedal Return Spring

This accessory combines an anti-rattle and brake lever spring. This will stop your stoplight from sticking and staying on. Instructions included.

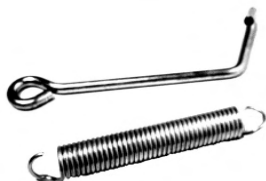

A2455ACC 28-31 Price Ea. \$ 6.00

New Clutch and Brake Pedal

The old worn out pedal can be cut off and a new forged ribbed pedal can be tig welded to the arms.



A2455B 28-31 Price Ea. \$ 16.00

Brake Stop Link Clevis Pin

This clevis pin is designed so you can hook the stop light switch to it. Used '28 thru July '29.



A2457 28-29 Price Ea. \$ 1.45

Brake Pedal to Cross Shaft Rod Clevis

Used on the brake pedal to cross shaft rod (A2465B).

Strong forged steel.



A2461 28-36 Price Ea. \$ 2.10

Brake Clevis Pins

For all brake rods. Standard size is 5/16" (.313") diameter. If the pin holes are worn, drill them out to the oversize diameter of .343 (11/32").



A2462 28-31 standard - need 14
Price Ea. \$ 0.18
A2463 28-31 Oversize - need 14
Price Ea. \$ 0.20

Service Brake Rod Clevis

You'll need 4 of these fish-eye clevis on the service brake rods.



A2466 28-36 Price Ea. \$ 2.00

Brake Pedal To Cross Shaft Rod

This rod connects the brake pedal to the cross shaft. The mushroom on the end is for '30-'31 style stop light switch, will work for July '28 thru '29, but is not correct.

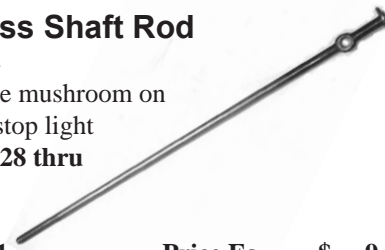

A2465B 28-31 Price Ea. \$ 9.35

BRAKES

Brake Cross Shaft Bushings

2 piece style bushings can be installed without removing the levers or the cross shaft. We stock 1 and 2 piece bushings.



A2477B 28-31 1pc/solid bronze
Price Ea. \$ 4.50

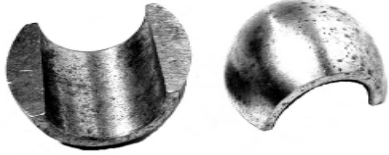

2 Pair are needed per car. 2 Halves is one pair.
A2477BS 28-31 2pc/split bronze
Price Pair \$ 8.70

Cross Shaft Repair Kit

Over the years the Brake Cross Shaft bushings (A2477B or BS) will wear on your Cross Shaft. You will need this repair kit to restore your shaft. The kit includes sleeves that are slid over the worn area on your cross shaft, and liquid metal to keep them in place. Special larger bore bronze bushings, and lever pins are included as well as instructions. One kit does both sides of the Cross Shaft.

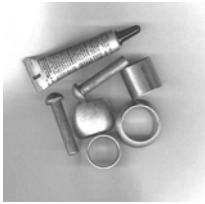

A2477RK 28-31 Price Set \$ 21.50

Brake Cross Shaft Brackets

This complete bracket set is used to attach the brake cross shaft to the frame. Order A2478/79MB for Bolts. 4 Piece Set. See A2485A.



A2478/79 28-31 Price Set/4 \$ 9.50

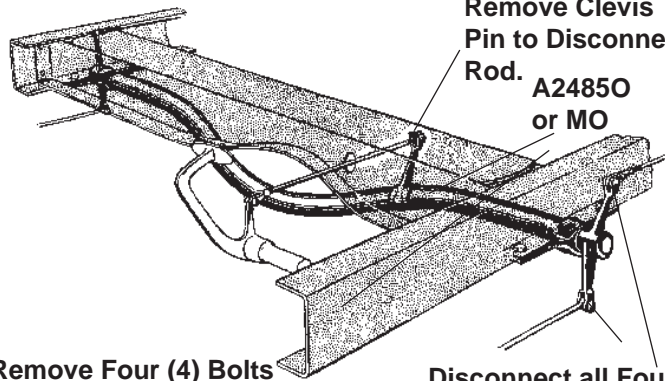

Remove Four (4) Bolts and Castle Nuts, Two (2) on each Side. A2478/79MB

Remove Clevis Pin to Disconnect Rod. A2485O or MO
Disconnect all Four Service Brake Rods A2499B

Brake Cross Shaft Bracket to Frame Bolts

This complete set of drilled bolts with castle nuts and cotter pins holds A2478/79 brackets to the frame. Locate Nuts at the bottom of the frame. 4 x 5/16"-24 x 3/4" Bolts, Castle Nuts and Cotter Pins.



A2478/79MB 28-31 Price Set/12 \$ 3.50

Rebuilt Service Brake Cross Shaft

These are completely rebuilt. Lever eyes are rebuilt back to standard Clevis Pins - A2462. See A2485A. A2485A fits here



A2485O 28-31 Outright Price Ea. \$ 100.00
A2485C Core Charge \$ 30.00
A2485E 28-31 Exchange Price Ea. \$ 70.00

Rebuilt Service Brake Cross Shaft with Modern Grease Fittings & Brackets

These are completely rebuilt. Lever eyes are rebuilt back to Standard Clevis Pins - A2462. You can purchase the cross shaft above as is or try our new version with the modern grease fitting installed.

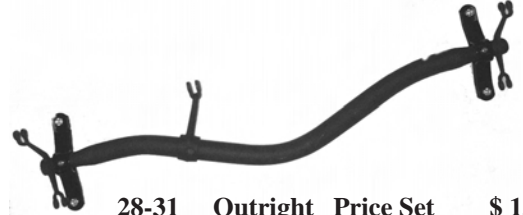

A2485MO 28-31 Outright Price Set \$ 135.00
A2485C Core Charge \$ 30.00
A2485ME 28-31 Exchange Price Set \$ 105.00

Modern Grease Fitting for Cross Shaft

The grease fitting that Henry Forgot. If you want to install these on your existing Cross Shaft, you will need this complete set. It is made up of a pair of bronze bushings (A2477BS), one pair of Brake Cross Shaft Brackets (A2478/79), a mounting bolt set (A2478/79MB), and a modern, threaded grease fitting. 1 Kit needed per car.



A2485A 28-31 Price/Set \$ 35.00

Brake Cross Shaft Rivets

Holds the arms on the service brake cross shaft. 5/16" x 1 1/2" Pin. Heat red hot and peen.



A2485RI 28-31 Price Pair \$ 1.40

Mike's "A" FORD-ABLE Parts

The open cupped side of the return spring points away from the service cross shaft, causing the brake shoes to be pulled away from the drums by the spring action.

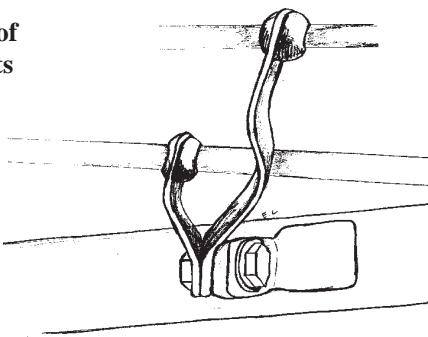

Brake Rod Anti-Rattle Return Springs

These excellent reproductions bolt to the bracket on the car and push against the nubs on the brake rods. Nuts for the spring bolts face rear. 6 Piece Set - 4 Long Springs, 2 Short Springs. Open side of cup is forward on front spring. Open side of cup faces rear for rear spring. Order A2504MB for bolts.



A2504/2866 28-31 Price Set/6 \$ 11.95

Brake Spring Style

Spring style used Sept. '31 to end of production. 4 Big Springs, 2 Small Springs, 4 Bolts, Nuts & Washers.

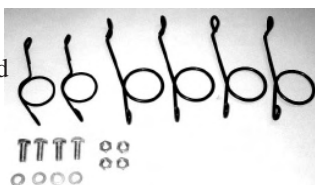

A2504/2866B Sept. '31 to End Price Set/18 \$ 9.65

Brake Anti-Rattle Spring Mounting Set

4 nuts, 4 bolts, 4 washers to mount the anti-rattle springs. Nuts for the spring bolts face rear. 5/16"-24 x 11/16" bolts.



A2504MB 28-31 Price Set/12 \$ 1.55

Brake Rods

51" Service Rod with forged ends. Need 4 per car. For clevis pins use A2466 - Page Gen. 50. Need 4.

A2499B 28-31 Service Rod Price Ea. \$ 11.55

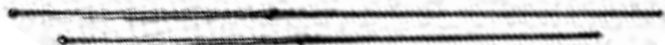

41 1/2" Emergency Rod with forged ends. For clevis pins use A2865A - Page 62. Need 2 per car.

A2864 28-31 Emergency Rod Price Ea. \$ 11.55

Complete set of 6 rods for both Service and Emergency brakes. A2499/B2864 28-31 Price Set/6 \$ 73.95

NOTE: The adjustable end of all brake rods face the front end of the car.

Brake Rod Lock Nut Set

This 7 piece set locks the clevis' in place on the brake rods.



A2499N 28-36 5/16-24 Price Set/7 \$ 1.00

Brake Buddy

A great new tool to keep under your seat for adjusting your brakes in a hurry. Complete Instructions included.



T2499 Price Ea. \$ 19.95

The following pieces are for use on Hydraulic Brake systems ONLY.

Rear Wheel Hub and Grease Seal



V1175 38-48 Need 2 Price Ea. \$ 2.95

Rear Wheel Bearing Snap Ring



V1180 38-48 Need 2 Price Ea. \$ 1.25

Front Hub Inner Grease Seal Retainer



V1190 35-48 Need 2 Price Ea. \$ 3.45

Rear Wheel Bearing



V1225 36-48 Need 2 Price Ea. \$ 29.65

Mike's "A" FORD-ABLE Parts



BRAKES

Bentley's Antique Auto Service - Make a stop at the Workshop next time you visit Mike's.



Save 5% - order online at www.mikes-afordable.com

Gen.53

FRONT BRAKE ASSEMBLY ILLUSTRATION

New now Available
M1001

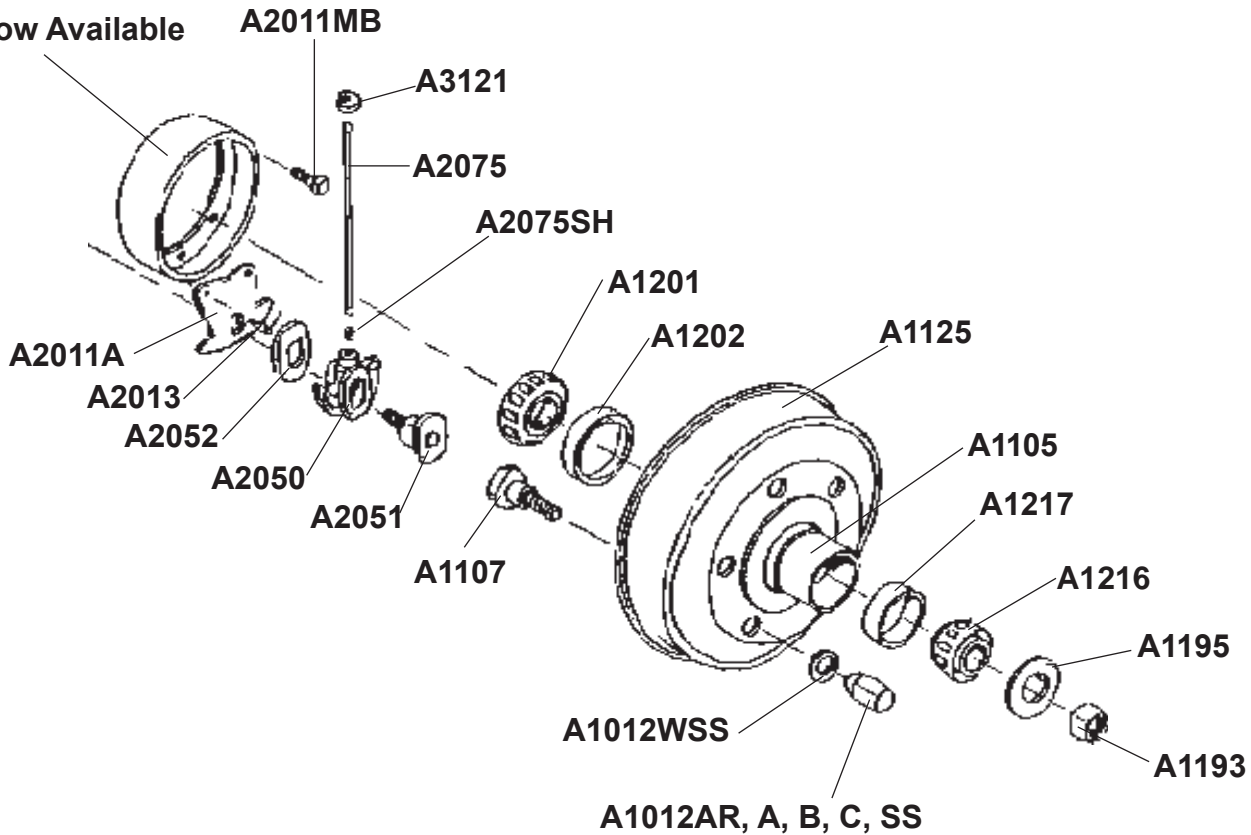

NOTE: Although several items may not be available as new reproduction parts, there is always a possibility that we might have some good used parts available - give us a call if you are looking for some hard to find parts!!

REAR SERVICE BRAKE ASSEMBLY

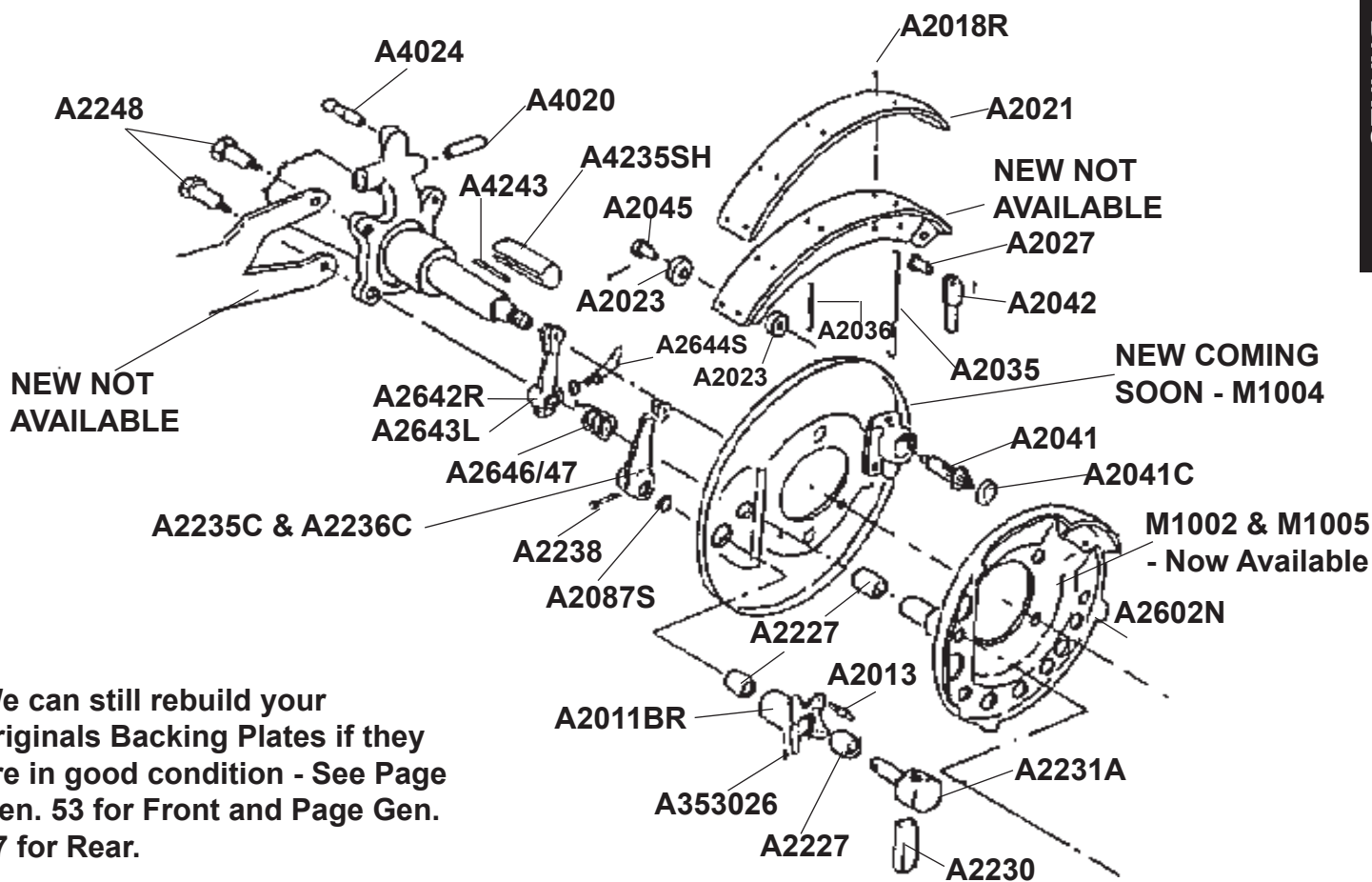

We can still rebuild your originals Backing Plates if they are in good condition - See Page Gen. 53 for Front and Page Gen. 57 for Rear.

NOTE: Although several items may not be available as new reproduction parts, there is always a possibility that we might have some good used parts available - give us a call if you are looking for some hard to find parts!!

REAR EMERGENCY BRAKE ASSEMBLY

BRAKES

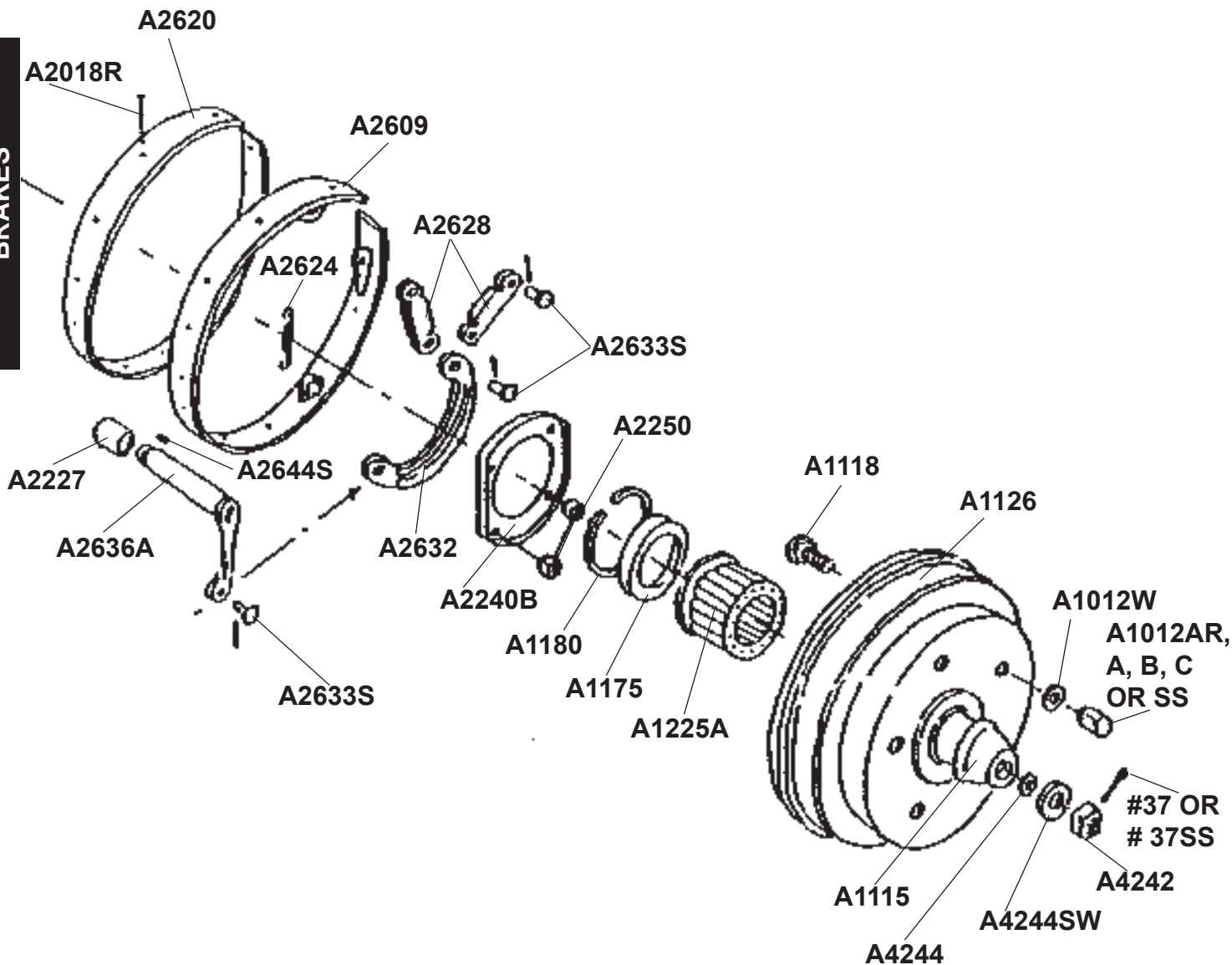

NOTE: Although several items may not be available as new reproduction parts, there is always a possibility that we might have some good used parts available - give us a call if you are looking for some hard to find parts!!

BRAKE SYSTEM ASSEMBLY

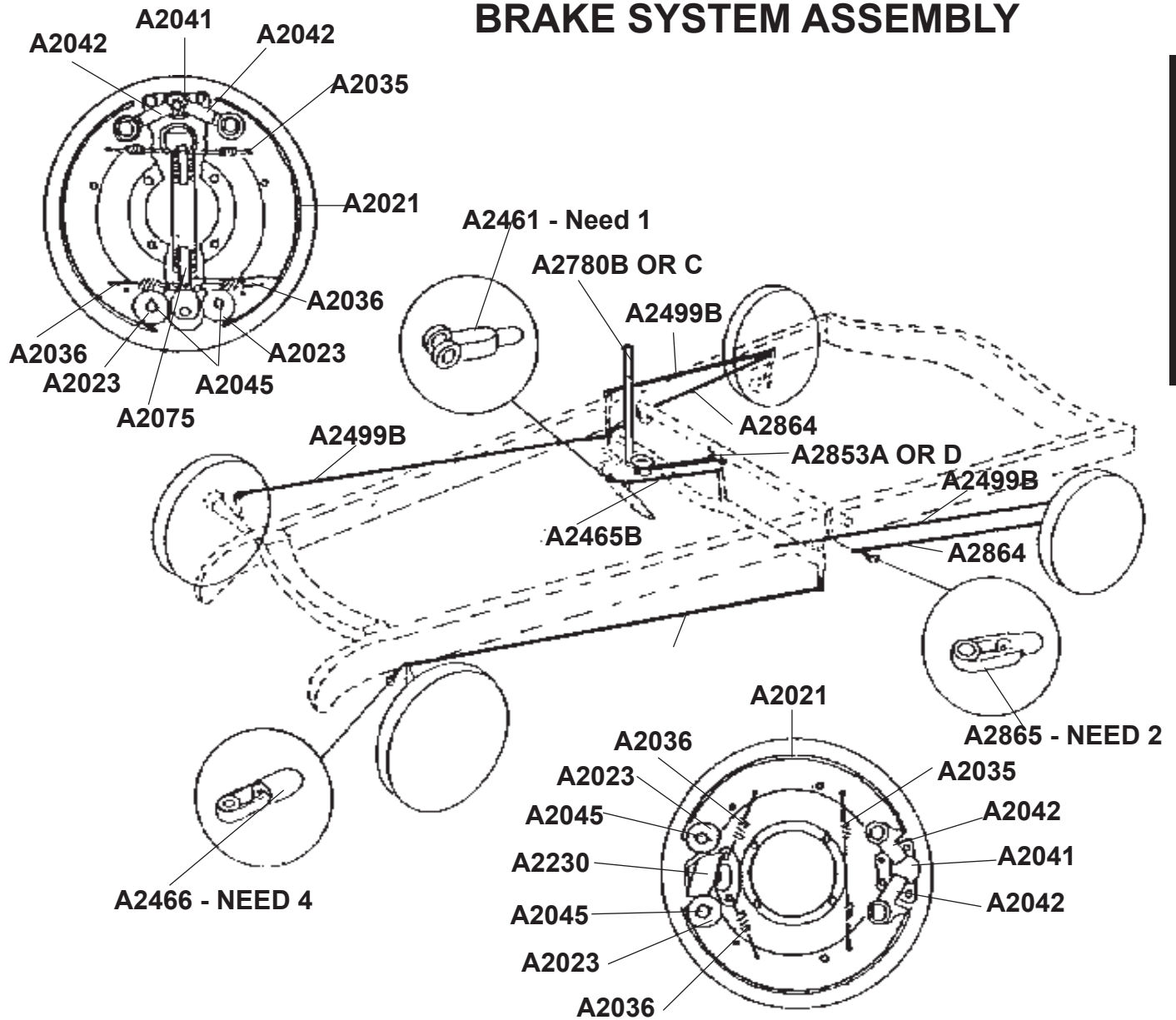

BRAKES

NOTE: Although several items may not be available as new reproduction parts, there is always a possibility that we might have some good used parts available - give us a call if you are looking for some hard to find parts!!

Mike's "A" FORD-ABLE Parts

EMERGENCY BRAKE

Specifications:

Diameter of drum:	9-5/8"
Width of Brake Shoe:	1"
Thickness of lining:	3/16"
Length of brake shoe:	28-3/4"
Material:	Woven wire and asbestos composition
Total brake shoe surface area:	57-1/2 Sq. Inches
Total braking area of 6 brake system: . . .	225-1/2 sq. Inches

NEW Emergency Carrier Plate

Over the years, some plates have been damaged beyond repair. These are new plates with bushings installed.

M1002	Left - Drivers Side		Price Ea. \$ 79.95
M1005	Right - Passenger		

Emergency Carrier Plate Rebuilt

Carrier is sandblasted, old bushings are removed and new bushings installed and reamed. New Toggle lever Housing Installed. EXCHANGE ONLY. YOUR OWN PLATES REBUILT.

A2600R	Right	Price Ea. \$ 41.00
A2601L	Left	Price Ea. \$ 41.00

Complete Rebuilt Carrier Plate, Powder Coated and Ready to Install. If your Toggle Lever Shaft Housing is worn or damaged - add A2637.

A2602YR	Right	Price Ea. \$ 110.00
A2602YL	Left	Price Ea. \$ 110.00

New Emergency Brake Band

Emergency brake lining is riveted to this steel band. You will need 2 per car.

A2609	28-31 Band Only	Price Ea. \$ 23.95
-------	-----------------	--------------------

Emergency Brake Lining

Linings and rivets for both wheels. These are not pre-drilled, you may want to send in your bands and let us do the work for you.

A2620	28-31	Price Pair \$ 25.50
-------	-------	---------------------

Lined New Emergency Brake Band

We can now supply you with lined NEW Emergency Brake Bands. These have been painted black with new (A2620) linings installed. Need 2 per Car.

A2620N	28-31	Price Ea. \$ 46.75
--------	-------	--------------------

Relined Used Emergency Brake Band

Let Mike reline your emergency brake band. Original band will be sandblasted, painted black, and have new lining (A2620) installed. EXCHANGE ONLY. If you do not have an exchange purchase the A2620N. Lining not included in this price.



A2620U	28-31	Labor Charge ONLY per Shoe for relining Bands	Price Ea. \$ 17.50
--------	-------	--	--------------------

Emergency Brake Retract Spring

Four are needed to refurbish emergency brakes. These are included with A2035/36.



A2624	28-31	Price Ea. \$ 0.55
-------	-------	-------------------

Emergency Brake Toggle Link

Four are needed to refurbish the emergency brakes. Be sure that they offset to make a straight line.

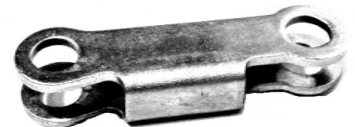

A2628	28-31	Need 4	Price Ea. \$ 5.85
-------	-------	--------	-------------------

Emergency Brake Connecting Lever

Two are needed to connect the emergency brake toggle lever to the two toggle links. Zinc Plated.



A2632	28-31	Price Ea. \$ 15.55
-------	-------	--------------------

Emergency Brake Toggle Lever Pins

These pins hook the emergency brake links together inside the drum. The head of these pins face towards the outside of the wheel.

6 - 3/8" x 11/16" and 2 - 3/8" x 9/16".
Need one set.

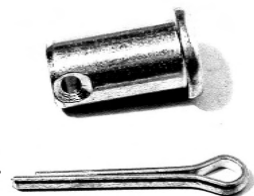

A2633S	28-31	Price Set/8 \$ 2.95
--------	-------	---------------------

Emergency Brake Toggle Lever

Goes through the backing plate. The emergency brake lever slips over this. Order A2227 Bushings for this shaft. A2642 is bolted to this. Includes Grease Fitting.



A2636A	28-31	Need 2	Price Ea. \$ 15.95
--------	-------	--------	--------------------

EMERGENCY BRAKES

Mike's "A" FORD-ABLE Parts

Emergency Brake Toggle Lever Shaft Housing Replacement

This tube is usually damaged on the carrier plate. Order this new tube, which includes bushings and reamed to fit new A2636A. The flange on the tube enables you to weld or swage into place.



A2637 28-31 Price Ea. \$ 10.25

Emergency Brake Levers

Emergency brake rods hook onto these levers at the rear backing plates.



A2642 28-31 Right Price Ea. \$ 13.95



A2643 28-32 Left Price Ea. \$ 13.95

Emergency Brake Lever Mounting Set

Use this set to mount the emergency brake levers onto the toggle levers.
2 - 5/16"-24 x 1 1/4" Bolt 2 L.W. And 2 Keys.
One set needed per car.



A2644S 28-31 Price Set/6 \$ 1.25

Emergency Lever Springs

These springs return the levers to the home position. Install outside the backing plate on the brake shaft. Caution: Left & Right Side.



A2646/47 Price Pair \$ 1.95

Emergency Brake Handles

Chrome Plated. An acceptable handle for the tour car, but for the fine point show car it would be better to have your original replated with the correct butler / bright finish combination. For mounting bolts see A2798.

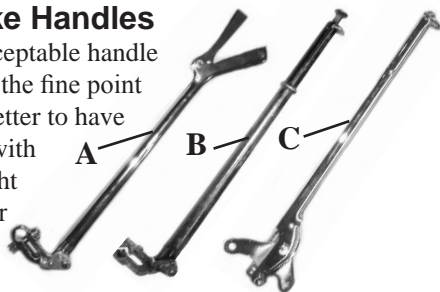

A2780A June 28 - Dec. 28 - Squeeze Type
Price Ea. \$ 75.00

A2780B Jan. '29 - July '29 - Brake to front mount
Push Button
Price Ea. \$ 75.00

A2780C July '29 - End - Brake to right mount
Push Button
Price Ea. \$ 75.00

Handle Extension

An extension that attaches to the A2780C Emergency Brake Lever, and makes the releasing of the handle easier. A duplication of an original accessory.



A2780EXT July '29 - End Price Ea. \$ 64.95

Emergency Brake Handle Clamp Bolts

Used to mount A2780B to the front of the gear shift.

1 x 3/8 - 24 x 1 17/32 with cross drilled end and nut. This bolt has a special head with one side cut off.
2 Piece Set. Used on Brake to Front Hand Brakes.



A2781MB June '28 - July '29 Price Set/2 \$ 1.95

Emergency Brake Handle Pivot Bolt

Thin headed bolt with castle nut for emergency brake handle that mounts on the side of the transmission.

3/8-24 x 1 1/4 Castle Nut.



A2782MB July '29 - End '31 Price Set/2 \$ 1.75

Emergency Hand Brake Lever To Shift Tower Bolts

Used to bolt the hand brake to the shift tower.



A2798 29-31 2 3/8-16 x 13/16" bolts + L.W.
Price Set/4 \$ 0.55

Emergency Hand Brake Handle Bushings

Used on the early squeeze Brake Handle mounted in front of the Gear Shift. Two per Set.



A2739 June 1928 - Dec. 1928
Price Pair \$ 1.20

Brake Boot

This rubber boot fits over the brake shaft to keep out road dirt.

See Page Gen. 121 for Gear Shift Boot.

A7000EB 28-31 Price Ea. \$ 2.95



Emergency Brake Handle Boot Reinforcing Plate

Used on the Hand Brake Handle which was mounted at the left subrail next to the cowl panel. The plate secured the rubber boot at the base of the handle.

RAR212 Beginning to June 1928
Price Ea. \$ 9.50



EMERGENCY BRAKES

Mike's "A" FORD-ABLE Parts

Emergency Brake Handle Blank Off Plate

Use this to cover up the Hand Brake Handle Hole on the left Subrail when the Brake Handle was moved from the left cowl subrail to the gear shift area.



RAR213 Beginning to June 1928
Price Ea. \$ 9.50

Emergency Hand Brake Lever Felt Washer

This felt washer goes onto the pawl rod inside the brake handle to eliminate rattling. You can use a coat hanger to help push it up into the bottom of the handle.



A2783 April '29- End '31 Price Ea. \$ 0.35

Emergency Brake Handle Pawl Rod

This rod goes inside the brake handle.



A2785 28-29 Price Ea. \$ 4.50
A2785B 30-31 Price Ea. \$ 4.35

Emergency Brake Handle Pawl

For Squeeze handle in front of gearshift.



A2786AR Feb. '28 - Sept. '28
Price Ea. \$ 10.00

Emergency Brake Handle Pawl

Used on bush button handles in front of gearshift.



A2786BR Dec. '28 - July '29
Price Ea. \$ 13.25

Emergency Brake Handle Pawl

For Brake handles on the right side of the gearshift - 1/4" thick pawl, to match ratchet.



A2786D July '29 - Late '30
Price Ea. \$ 10.25

Emergency Brake Handle Pawl

Case hardened, zinc plated, 5/16" thick to match 5/16" ratchet. To be used on Brake to Right Handles.



A2786E Late 30 - End
Price Ea. \$ 9.95

Emergency Brake Handle Button and Pin

Chrome finished thumb button with mounting pin. For 3/8" diameter shaft. Includes Pin.



A2791 29-31 Price Set \$ 3.10

Emergency Brake Handle Spring

This spring secures the pawl rod inside the brake handle.

Used on Brake to Right Brake Handles.

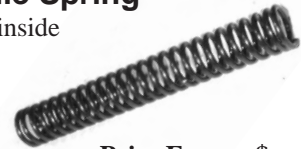

A2793 28-31 Price Ea. \$ 0.50

Emergency Handle Pin

This dual function clevis pin holds the pawl in place and secures the rod that runs from the cross shaft to the brake handle.

Used July '29 till end. 5/16 x 1 1/8".



A2794 29-31 Price Ea. \$ 0.70

Emergency Brake Handle Ratchet

For the emergency brake handle.

Used July '29 thru 1931.

Heat treated, use Pawl A2786E.



A2795 29-31 Price Ea. \$ 19.95

Emergency Brake Handle Ratchet

Used on the squeeze handle located in front of the gearshift - Used from June '28 - Dec. '28.



A2795AR 1928 Price Ea. \$ 15.00

EMERGENCY BRAKES

Mike's "A" FORD-ABLE Parts

1928 To 1930 Style

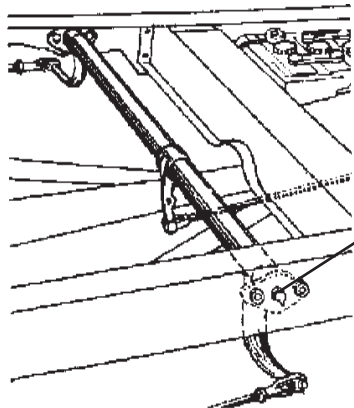

Remove Grease Fitting and Two (2) Mounting Bolts

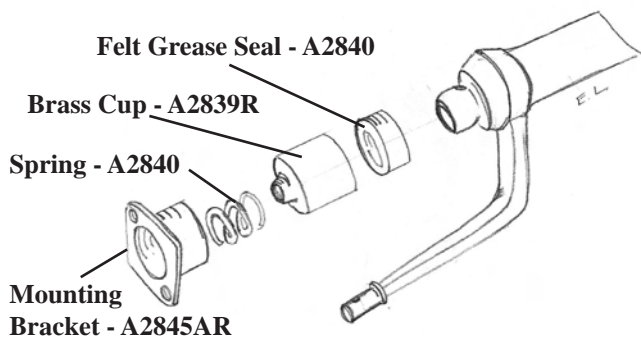

Felt Grease Seal - A2840

Brass Cup - A2839R

Spring - A2840

Mounting Bracket - A2845AR

End Bracket Assembly

1931 Style

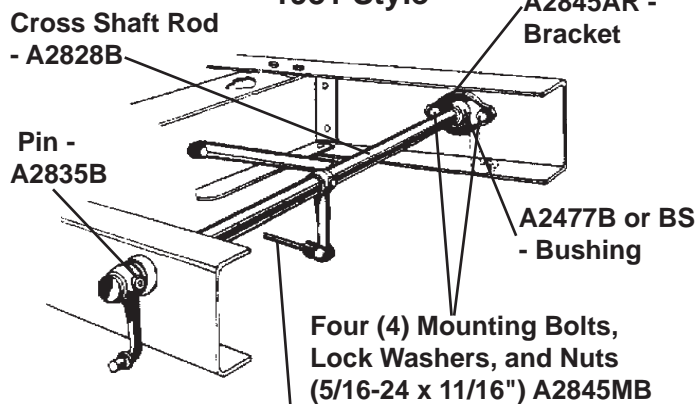

Cross Shaft Rod - A2828B

A2845AR - Bracket

Pin - A2835B

A2477B or BS - Bushing

Four (4) Mounting Bolts, Lock Washers, and Nuts (5/16-24 x 11/16") A2845MB

Handle to Cross Shaft Rod - A2853D

Thanks to Les Andrews for the use of his drawings.

Emergency Brake Cross Shaft Rod

Steel Rod only with 3 holes predrilled for arms. April '30 - End '31.



A2828B April '30 - End '31 Price Ea. \$ 21.95

Emergency Brake Cross Shaft Lever Pin

Punch out this 5/16" x 1 1/4" tapered pin to remove arms before installing new bushings (A2477B). Reassemble the shaft using these tapered pins. Need 2.



(NOTE: You wouldn't have to remove the arms if you used the A2477BS Split Bushings - but this is not recommended.)

A2835B 30-31 Price Pair \$ 0.90

Emergency Brake Cross Shaft Bearing

The brass bushings at the end of the emergency cross shaft. Made from the Ford Blueprint.



A2839R 28 - Early '30 Price Pair \$ 24.00

Emergency Brake Cross Shaft Spring And Felts

2 Springs and 2 felts only situated at each end of emergency cross shaft.



A2840 1928 - April '30 Price Set/4 \$ 2.00

Emergency Brake Cross Shaft Brackets

Holds the shaft to the frame.

2 Needed per car.

Used with A2839R and A2840.



A2845AR 28 - Early 30 Price Ea. \$ 10.95

Emergency Brake Cross Shaft Support Bolts

Does not include brackets.



4 x 5/16-24 11/16 Bolts washers and nuts.

A2845MB 28-31 Price Set/12 \$ 1.45

EMERGENCY BRAKES

Mike's "A" FORD-ABLE Parts

Emergency Handle to X-Shaft Rod

This rod connects the brake handle to the cross shaft. With forged ends.



A2853A '28 - July '29 20 3/4"
Price Ea. \$ 10.95



Yoke on each end.

A2853D Jul '29-31 18 3/4" Price Ea. \$ 19.50

Emergency Brake Rod Clevis

This clevis screws on to the end of the Emergency Brake Rods (A2865A) to connect to the Brake Cross Shaft (A2485).



A2865A 28-31 Need 2 Price Ea. \$ 2.45

Emergency Brake Rods

41 1/2" Emergency Rod with forged ends. For clevis pins use A2865A. Need 2 per car.



A2864 28-31 Emergency Rod
Price Ea. \$ 11.55

For complete Brake Rod Sets - See Page Gen. 52.

Do you like
the sound of
FREE
Shipping!!

Order online
and get a 5%
Discount -
this could
cover your
shipping
costs!!

Mike's "A" FORD-ABLE Parts

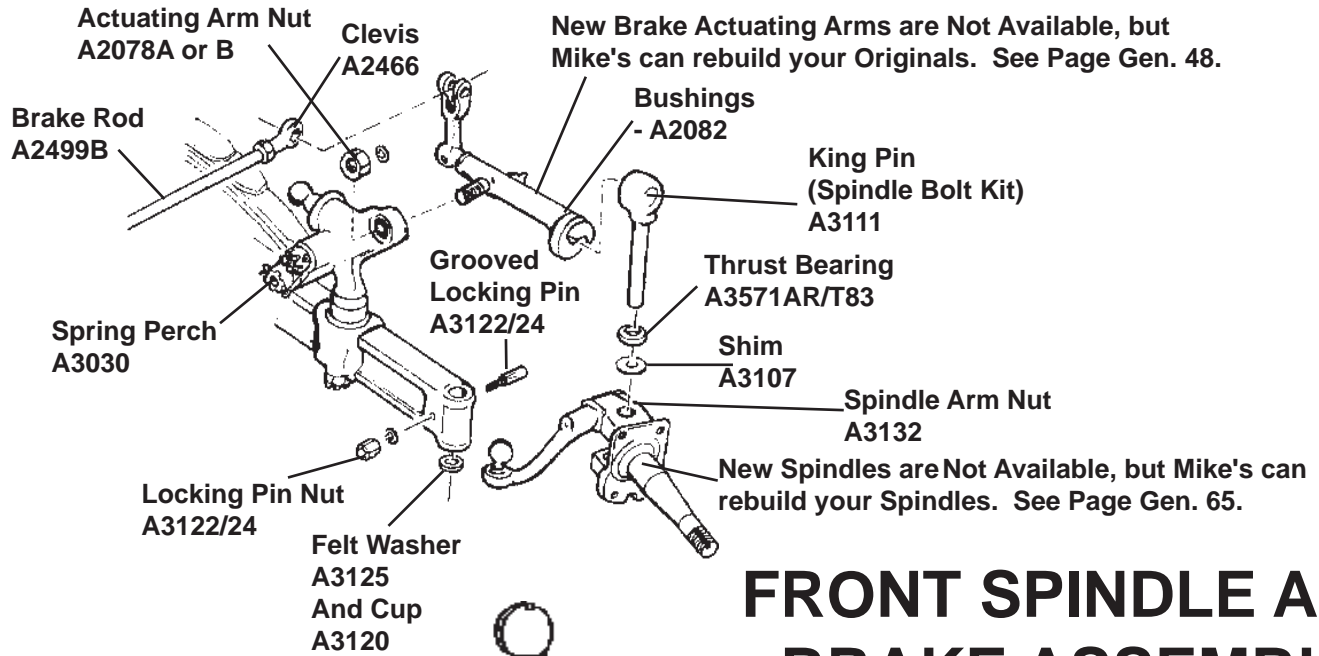

FRONT SPINDLE AND BRAKE ASSEMBLY

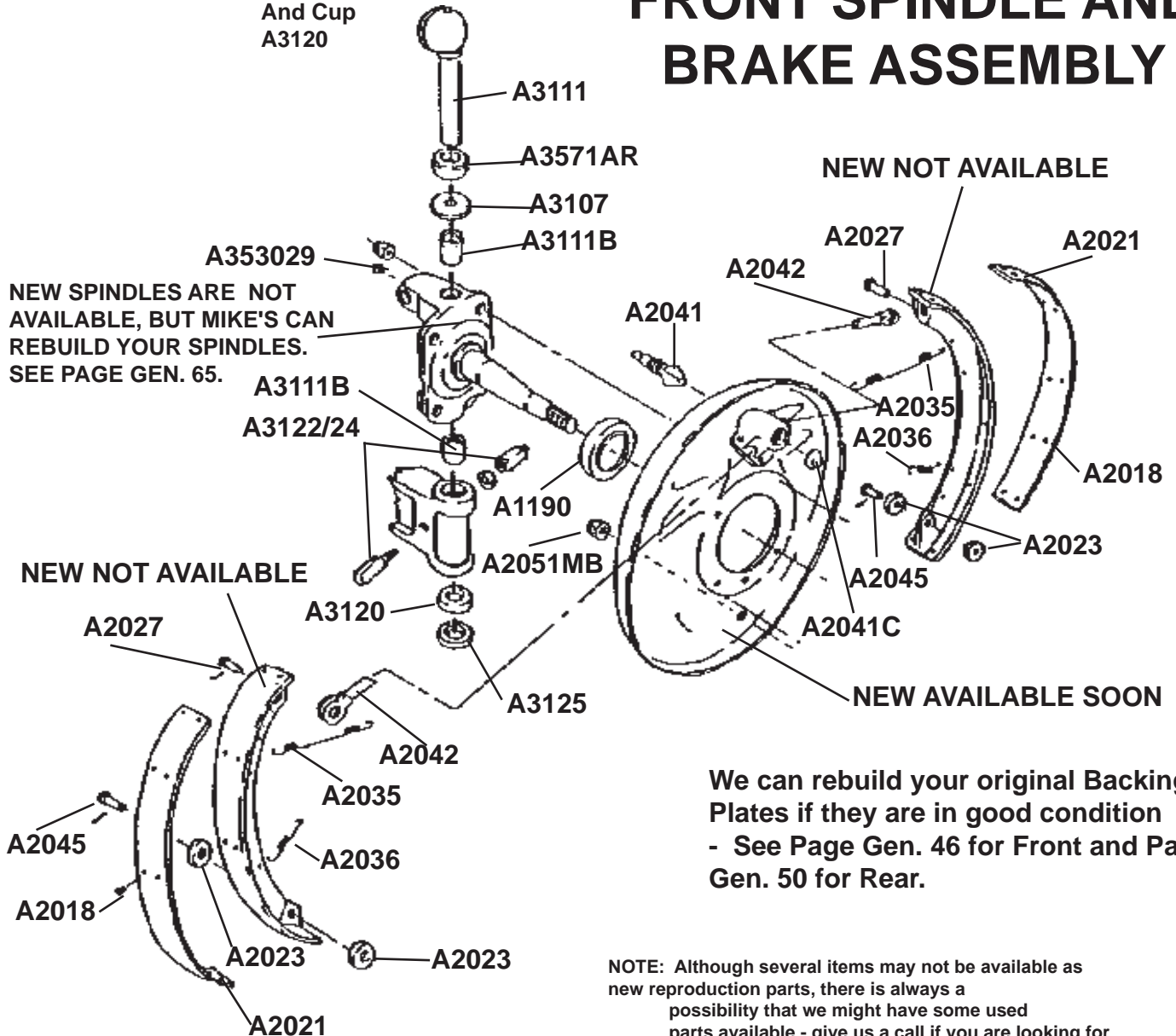

EMERGENCY BRAKES

We can rebuild your original Backing Plates if they are in good condition - See Page Gen. 46 for Front and Page Gen. 50 for Rear.

NOTE: Although several items may not be available as new reproduction parts, there is always a possibility that we might have some used parts available - give us a call if you are looking for some hard to find parts!!

Mike's "A" FORD-ABLE Parts

FRONT END PARTS

Specifications

Material:	Chrome alloy forging
Tensile strength:	125,00 to 145,000 PSI
Caster:	5° (forward tilt)
Toe in:	1/16" ± 1/32"
Camber:	1-13/16"
Spindle bolt (king pin):	diameter: .8125" .0005"; length: 5-5/16"
Spindle bolt bearing:	Timken T83, Nice 5699
Spindle bolt to bearing clearance:001 to .002"
Front wheel bearings:	
Inner bearing:	Timken 15118;
Cup:	Timken 15250
Outer bearing:	Timken 09074; cup: Timken 09196

The following new parts are required to complete a restoration of your Front End & Radius. This is only a guide - do not assume that this is all that is needed, all other parts need to be thoroughly checked and rebuilt if necessary. If rebuilding is something that you do not wish to do, all of the original parts can be rebuilt at Mike's "A" Ford-able Parts.

1. Spindle Bolt Kit (King Pins) - **A3111** or **A3111K**
2. Spindle Bolt Reamer - **T3112R** or **T3112TR**
3. Tie Rod and Drag Link Rebuild Set - **A3305SE** (Teflon)
4. Tie Rod and Drag Link End Plug Tool - **T3305T**
5. Tie Rod and Drag Link Seals - **A3332** and Caps - **A3333**
6. Radius Ball Felt - **A3425**
7. Radius Ball Pin - **A3441**
8. Radius Ball Kit - **A3440S** or **A3440RE**.

Why not send your Front Spindles **A3111RE**, Single **A3130RE** and Double Arm **A3131RE** Steering Spindles for reballing and your Pitman Arm **A3590RE** for shortening and reballing.

Front Spring Perch

Excellent Quality. Comes with bushing installed. See **Page Gen. 99** for Shackles & Reamers.



A3030 28-31 Price Ea. \$ 59.95

***** MIKE'S TIPS *****

Front End problems can cause difficult steering, bad wearing of your tires, and a shimmy. Check for King Pin play, point wheels forward and grasp the wheel at the top and pull back and forth. There should be little or no movement at all. To check for steering ball play, have someone turn the steering wheel and watch the movement of the linkage.

Front Spring Perch Nut

Holds the perch in the front axle. 5/8" - 18.
2 Needed.
Torque to 100 Ft. Lbs.



A3036B 1928 - 1948 2 needed
Price Ea. \$ 1.35

Front Spring Perch Bushing

Two per side are needed - one in the perch, one in the leaf spring. Spring shackle fits into this. For reaming, use a 14.5mm drill with a 1/2" shank.

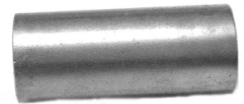

A3034 28-31 Ream to .571
Price Ea. \$ 0.45

Universal Bushing Installation & Removal Tool

An ideal Tool to remove bushings from Rear Brake Camshaft, Rear & Front Spring and Perch Bushings.



T3820/44T 28-31 Price Ea. \$ 10.95

King Pin Shim

Use this thin washer as a spacer to alleviate up-and-down play in the king pins. You may find that at least two must be added.

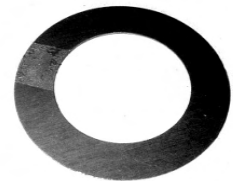

A3107 28-31 .010 Price Ea. \$ 0.40

FRONT END PARTS

Mike's "A" FORD-ABLE Parts

Front Spindle Bolt Kit (No King Pins)

If your king pins are still good, this set will make the assembly like new.

4 Bushings, 4 Thrust Washers, 2 Bearings, 2 Large Felt Washer, 2 Small Felt Washers, 2 Felt Cups, 2 Locking Bolts and 2 Nuts.



A3111K 28-41 Ream bushings to .814"
Price Kit/22 \$ 19.40

King Pins Only

If you are just needing the King Pins and not the complete Set - we have got just the thing for you. Sold as Pairs only.



A3111KP Price Pair \$ 61.00

Front Spindle Bolt Kit (with King Pins)

King Pin Kit. This set replaces all the worn spindle parts for both sides. Helps/eliminates hard steering and front end shimmy. Please be aware that there are left and right sided pins.



A3111 28-31 Price Set/24 \$ 79.95

King Pin Bushing (Spindle Bushing)

Comes in Kits A3111K and A3111.



A3111B 28-31 Ream to .814"
Price Ea. \$ 1.50

Front Spindle Felt Cup

This cups holds A3125 Felt Washer in place. These are the correct size. Need 2 per car. Comes in Kits A3111K and A3111.



A3120 28-37 Price Ea. \$ 0.65

Small King Pin Felt

This fits inside the spindle bolt with the front brake operating pin through the middle of it. 3/4" x 1/2" x 3/16" hole. Comes in Kits A3111K and A3111. Need 2.



A3121 28-37 Price Ea. \$ 0.45

Large King Pin Felt

This fits inside the cup washer at the lower end. Comes in Kits A3111K and A3111. Need 2.



A3125 28-37 Price Ea. \$ 0.50

King Pin & Steering Worm Bearing

Open side of bearing faces down to keep water out. Please note that the Timken bearings are not always available. Comes in Kits A3111K and A3111. Need 2.



A3123 28-32 USA Made Price Ea. \$ 3.00

Front Spindle Bolt Bushing Reamer

19" Long reamer to ream both bushings in line. Reams to .814. See Mike's Tips on page Gen. 49.



T3112R 28-31 Price Ea. \$ 135.00



T3112TR 28-31 Price Ea. \$ 29.95

Rebuilt Spindles - Exchange ONLY

Send in your front spindles for Mike's to Rebuild. These are machined to the correct specifications, so that the bearing has a nice tight fit. Bushings Included. Bad threads can also be repaired.



NOTE: To test the fit on front spindle bearings, the outer bearing race should NOT spin when the weight of the car is on the wheels. If you require your bushings to be reamed, you must send in your king pins for perfect fit. See A1193 & A1195 for bolts and washers on page Gen. 41.

A3111RE EXCHANGE ONLY Price Ea. \$ 57.50

Locking Bolt/Nut

Long head and short hex on head - early style. Used from the beginning of production until April 1929.



A3122/24AR 1928 - April 1929 Price Ea. \$ 18.50

Locking Bolt/Nut

Long head on long hex - early style.



A3122/24B April - August 1929 Price Ea. \$ 18.50

FRONT END PARTS

Mike's "A" FORD-ABLE Parts

Locking Bolt/Nut

Secure your spindle bolt in place on the axle with this special bolt, nut, and lock washer. Comes in Kits **A3111K** and **A3111**. 3 Piece Set. 1 set needed per side.



A3122/24 **30-31** **Price Set** \$ **3.90**

Steering Spindle Arm - Exchange Only

Made in the USA. Let Mike refurbish your right side steering spindle arm by installing a new cold-rolled steel ball on it. **Please remove any grease or dirt before sending.** Mike recommends that you purchase new spindle arm nuts **A3132** as some threads are so worn that the new nuts will ensure a tighter fit. If your balls (**A3311W**) have been replaced before, don't send them in for exchange. We replace only original worn balls. Mike recommends use of the **Easy Steer Kit (A3305M - Page Gen. 67)** - with new balls.



A3130RE **28-31** **EXCHANGE ONLY**
Price Ea. \$ **34.50**

Steering Spindle Double Arm - Exchange Only

Let Mike refurbish your left side steering spindle arm by installing a new cold-rolled steel ball on it. **Please remove any grease or dirt before sending.** Mike recommends that you purchase new spindle arm nuts **A3132** as some threads are so worn that the new nuts will ensure a tighter fit. If your balls (**A3311W**) have been replaced before, don't send them in for exchange. We replace only original worn balls. Mike recommends use of the **Easy Steer Kit (A3305M - Page Gen. 67)** - with new balls.



A3131RE **28-31** **EXCHANGE ONLY**
Price Ea. \$ **60.00**

Steering Spindle Arm Nut

This unique nut holds the spindle to the front axle radius.



A3132 **28-31** **2 needed 9/16" - 18**
Price Ea. \$ **2.65**

New Steering Pitman Arm

Pitman arm, standard length. Mike recommends use of the **Easy Steer Kit (A3305M - Page Gen. 67)** - with new balls.



A3590A **28-31** **STD** **Price Ea.** \$ **32.95**

New Shortened Pitman Arm

A shortened version of the **A3590A** New Steering Pitman Arm. Shortened by 1 1/2" for better steering. No exchange needed.



A3590USA **28-31** **Price Ea.** \$ **68.75**

Original Pitman Arm (Shortened)

Let Mike refurbish your original pitman arm by installing a new cold rolled steel ball. Mike suggests you let us shorten it by 1 1/2" for better steering. **Please remove any grease or dirt before sending.** If your balls (**A3311W**) have been replaced before, don't send them in for exchange. We replace only original worn balls.



A3590RE **28-31** **EXCHANGE ONLY** \$ **43.75**

Pitman Arm Bolt

Special Bolt and Castle nut attaches the pitman arm to the steering sector.



Don't forget to order your Cotter Pins - #37 or #37SS.

A3590MB **28-31** **7/16" - 20 x 1 15/16"**
x 5/8" Castle Nut
Price Set/2 \$ **2.75**

Replacement Ball Studs - Steering and Pitman Arm

Worn steering balls make steering less responsive. Cut off the old ball, drill the hole, insert the ball stud, and weld it. Four are needed.



A3311W **28-31** **Price Ea.** \$ **5.00**

Threaded Ball Stud - Steering and Pitman Arm

Later Fords used a threaded steering ball.



A3311 **Late 31-32** **Price Ea.** \$ **4.20**

FRONT END PARTS

Gen.66

Give us a call -1-888-TRY-MIKE (879-6453)

Have an "A" Day!

RADIUS

Specifications:

Ball felt size: 3/4" x 1-3/4 x 3"

Steering Stabilizer

Complete with brackets and Instructions.
Design may change depending on supplier.



A3281STAB 28-31 Price Kit \$ 89.95

Tie Rod

This tie rod has left hand threads on one end and right hand threads on the other. Solid Steel - Replace if Drag Link has worn a low spot on your old one. Threads are 11/16-24. **PLEASE NOTE:** Shipped in a PVC Tube for protection. 43 1/2" Long.



A3281 28-34 Price Ea. \$ 17.50

Tie Rod Bolts

Holds the tie rod to the tie rod ends;
6 Piece set.

2 x 3/8 - 24 x 1 5/16 Bolts Castle
Nuts & Cotter pins.

The nut faces down - The bolt is on the rear side of the tie rod.



A3285/86MB 28-31 Price Set/6 \$ 5.00

Tie Rod Ends

No Internal parts - Bolts and Nuts are included. Use original if possible.

Tie Rod Ends used threaded grease fittings until **Sept. '30** and the fitting faced forward. Thereafter the fittings changed to a press in style and faced towards the rear.



A3285 28-31 Right Price Ea. \$ 13.75

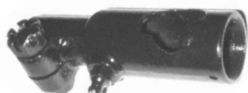

A3286 28-31 Left Price Ea. \$ 13.75

Tie Rod/Drag Link End Plug Tool

You can remove the threaded end plugs on the tie rod and drag link ends with this tool. Use 7/8" wrench.



T3305T 28-34 Price Ea. \$ 5.00

Instructions for screwing in the Tie Rod or Drag Link End Plug.

Compress the spring by 25% to maintain the correct tension then measure the length of the spring. At the contact point of the End Plug and the inside parts - continue to tighten one fourth the length of the spring - then align the slot for the cotter pin.

Drag Link

This arm goes from the pitman arm to the front end. The innards to complete a rebuild are A3305S or A3305SE. A3305SE is recommended for longer life. The ball location is different on each end of the Drag Link Rod. Before **Oct. '28** the hole is closest to the end for the pitman arm. In **Oct. '28** this was reversed - the pitman arm ball enters closer to the center of the rod.



A3305 28-31 Price Ea. \$ 64.95

How to Install Easy Steer Kit - A3305M

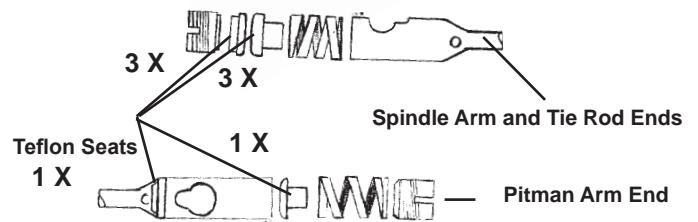

Bronze Impregnated Teflon Easy Steer Kit

This bronze impregnated Teflon is a new Space Age material that will not wear. The manufacturer has over 12,000 miles on his Model A with no sign of wear. Far superior than the white teflon kits.

Includes Instructions.
Need 1 set per car.

A3305M 28-31 Price Set \$ 44.95



Bronze Impregnated Teflon Seats

Replace your worn white teflon seats with these new space age bronze impregnated seats. A far superior quality product.

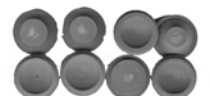

A3305BRZ 28-34 Price Set/8 \$ 36.00

Mike's "A" FORD-ABLE Parts

Tie Rod / Drag Link Rebuild Kit

This set includes all the parts needed in the ends of the tie rod and the drag link. Two sets needed per car.



A3305S 28-34 Price Kit/9 \$ 9.50

Tie Rod and Drag Link Seal

This rubber seal keeps the grease in and dirt out.



A3332 28-34 4 in a set Price Set/4 \$ 3.00

Tie Rod and Drag Link Metal Cap

This cap holds the rubber seal in place around the steering balls.



A3333 28-34 4 in a set Price Set/4 \$ 2.95

Radius Rod Ball Felt

This heavy felt pad fits inside the bell housing over the radius ball. 2 3/4 x 1 3/4 x 3/4".

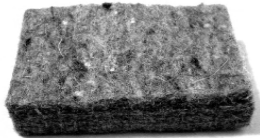

A3425 28-31 Price Ea. \$ 0.95

Radius Bushings

For the original style radius; these bushings slide over the bolts as spacers.



A3435 28-31 Price Pair \$ 1.35

Rod Socket Replacement Set

A complete radius ball cap assembly. Cast Iron. Included in set are:

- 1 Pair - A3440A - Bolts
- 2 A3440N - Nuts
- 2 Lock Washers
- 1 A3446 - Ball and Socket Cap and Plate.



A3440RE 28-31 Price Set/9 \$ 7.50

Radius Ball Socket Bolts

A slotted head on these special bolts take a retaining pin to hold them in place.



A3440A 28-31 Price Pair \$ 2.95

Radius Rod Nuts

Slotted nuts hold the radius rod cap in place. 7/16"-20.



A3440N 28-31 2 needed Price Ea. \$ 2.50

Radius Ball

Made for A3440RE. This oil-resistant rubber ball goes over the steel radius ball.



A3446 28-31 Price Ea. \$ 1.75

Radius Ball Kit

Stamped steel as original. The original style radius cap assembly. If ball is worn, use a large fender washer to take up play. See A3405W below.



A3440S Price Set/10 \$ 17.95

Front Radius Rod Ball Spacer Washer

This spacer washer is to be used to take up wear on the front radius rod ball. Use one or two washers as needed with the original style stamped steel rod ball socket, NOT the cast iron after market set with the rubber ball. Apply a little grease before installation.



A3405W 28-31 Price Ea. \$ 2.00

Radius Cap Springs

For A3440S - original style steering.



A3445 28-31 Price Pair \$ 1.25

Radius Ball Kit Retainer Pin

For A3440A Radius Ball socket Bolts.



A3441 28-31 Price Ea. \$ 0.95

RADIUS

Replacement Radius Ball Repair Kit

Most people do not realize how extremely important the radius ball assembly is to the Model "A". If it is not in good condition it will cause all sorts of problems with your front end.

We have come up with a replacement which includes a grease fitting. The original ball has to be cut away from the radius arm / wish bone and a new hole drilled and welded into place. The set includes complete housing A3440S (see Page Gen. 68) and ball.

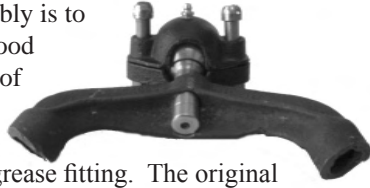

A3440REP 28-31 Price Set \$ 59.95

Setting Model A Toe-In

Toe-in of the front wheels of a Model A was changed in September 1928 - should be 1/16" (plus or minus 1/32") i.e. 1/16" closer at the front than at the rear. Correct toe-in saves wear on tires and makes steering and handling easier. Toe-in is the only adjustment the average Model A driver can make on the front end. Caster (the angle of the king pin from the vertical) and camber (toe-in measured vertically) were "set at the factory" and can be adjusted only by a professional front end shop capable of bending axles and wishbones. Caster should be 5 Degrees and camber 1 13/16.

A special gauge must be used to set toe-in. There are several types on the market, but a simple and effective one can be homemade using scrap lumber and basic carpenter tools, and a folding carpenter's rule with an extension for making inside measurements.

To use the gauge to measure toe-in:

1. Park the Model A on a level spot. Place the gauge on the floor between the two front tires, in front of the axle, so that it will touch the tires at the narrowest point between them. Make a mark (chalk, pencil, felt tip pen, masking tape, etc.) on one tire where the end of the gauge will touch it. Slide out the rule extension until it touches the tire (with the opposite end touching the other tire) and write down the measurement.
2. Remove the gauge and roll the car forward until the mark you made on the tire can be touched again with the gauge behind the axle, and under the wishbone. (NOTE: It is necessary to roll the car forward so you will be measuring between the same two spots on the tires. Remember, 1/16" is not much and some tires have bulges which might give incorrect measurements if you didn't measure between the same points each time.)
3. Slide the rule extension out again so each end of the gauge touches the tires at the correct spot and note the measurement. If the measurement is more than for the front it will show you how much toe-in you have. If it is less, you have toe-out.

4. If it reads more or less than 1/16" (plus or minus 1/32") from the measurement taken in front of the axle, adjustment is required. Loosen the clamp bolts on each tie rod end and use a pipe wrench or Vise-Grips to turn the tie rod in whichever direction necessary to get the correct toe-in measurement. You may have to repeat steps 1, through 3, a few times until you get it just right. If you keep getting inconsistent measurements, make sure the steering arm ball seats are not loose. When you are satisfied with the setting, retighten the tie rod end clamp bolts and replace the cotter pins in the castle nuts.

NOTE: There are several different styles of Model A tie-rod ends. All should be mounted with the clamp bolt to the rear even though some have the grease fitting either to the front or to the rear.

Order Online Now and Save 5%

Visit our website for all your Model "A" needs.



www.mikes-afordable.com

Steering Worm - 7 Tooth

For the 7 tooth style steering boxes.

Right hand worm also available on request.



A3524A	28- March 30	Price Ea.	\$ 39.95
A3524-ARX	Right Hand Drive	Price Ea.	\$ 65.00

Steering Worm - 2 Tooth

For the 2 tooth style steering box.

Production began in **Feb 1929** so

there is overlap with the above. Right hand worm also available on request.



A3524CD	29-31 2 Tooth	Price Ea.	\$ 53.95
A3524-CRX	Right Hand Drive	Price Ea.	\$ 54.40

Steering Worm Installation

Have your old worm replaced on your steering shaft.

Labor Only - Order Worm **A3524A** or **A3524CD** Separately.



A3525A	28-29	Seven Tooth Shaft	Price Ea.	\$ 30.00
A3525B	29-31	Two Tooth Shaft	Price Ea.	\$ 25.00

Steering Shaft Thread Repair

If your threads are stripped or damaged, send it in to us for repair. The shaft will be drilled out and tapped and the threaded plug (**A3526T**) with a hold down the center will be installed to have that original look. Torque steering wheel nut to no more than 25 - 30 foot Lbs with a torque wrench.



A3526	29-31 2 Tooth	Price Ea.	\$ 45.00
-------	---------------	-----------	----------

Steering Shaft Thread

This is the Piece that is used to repair (**A3526**) if you want to do the job yourself, see The Restorer Jan/Feb 2001 issue for Instructions. Use a Torque Wrench, but **no** more than 25-30 FT. Lbs.

Instructions available upon request.



A3526T	29-31 2 Tooth	Price Ea.	\$ 12.50
--------	---------------	-----------	----------

Steering Box Plug

This is the oil plug on the top of the steering box.

Use only **600W** for lubrication - See Page 29.

1/4" Pipe Thread.

A3538	Oct. '29 till end	Price Ea.	\$ 0.50
-------	-------------------	-----------	---------



Steering Light Switch Rod Bushing

This bushing spaces the light switch rod away from the steering wheel. Use this as an anti rattle bushing.



A3529	29-32	Price Ea.	\$ 1.95
-------	-------	-----------	---------

Steering Spark and Gas Rods

'28 x '29 = 30" long. '30 - '31 = 31" long.

A3540SSA	28-29	Stainless	Price Ea.	\$ 24.
A3540SSB	30-31	Stainless	Price Ea.	\$ 24.

A3540A	28-29	Chrome	Price Ea.	\$ 16.
A3540B	30-31	Chrome	Price Ea.	\$ 16.

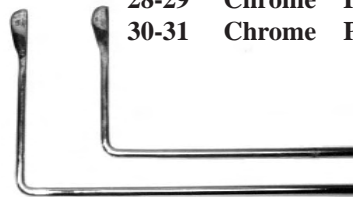

2 Rods needed per car.

Used to be nickel on the old Fords.

A3540AN	28-29	Nickel	Price Ea.	\$ 16.
A3540BN	30-31	Nickel	Price Ea.	\$ 16.

Steering Spark & Gas Rod Anti-Rattlers

A pair of small felt bushings to eliminate rattles from the spark and gas rods. Original rods were notched to show location about 14" from the handle end.



A3540F	28-31	Price Pair	\$ 0.
--------	-------	------------	-------

***** Mike's Tip *****

Use a 7/16" nut driver to compress the control arm and spring so the pin can be inserted into the hole in the spark and gas rods.

Steering Control Rod Arms

Need 2 per car.

Fits on the ends of the spark and gas rods. The gas arm on the right, the ball faces up.



A3541	28-31	Price Ea.	\$ 5.
-------	-------	-----------	-------

Steering Control Rod Arms Pins

Holds the above arm on the control rods.



A3542	28-31	2 - 3/32" x 21/32"	Price Pair	\$ 0.
-------	-------	--------------------	------------	-------

Steering Control Rod Springs

These Springs tightly hold the spark and gas rods in place at the bottom just above the control rod arms.



A3545	28-31	Price Pair	\$ 0.
-------	-------	------------	-------

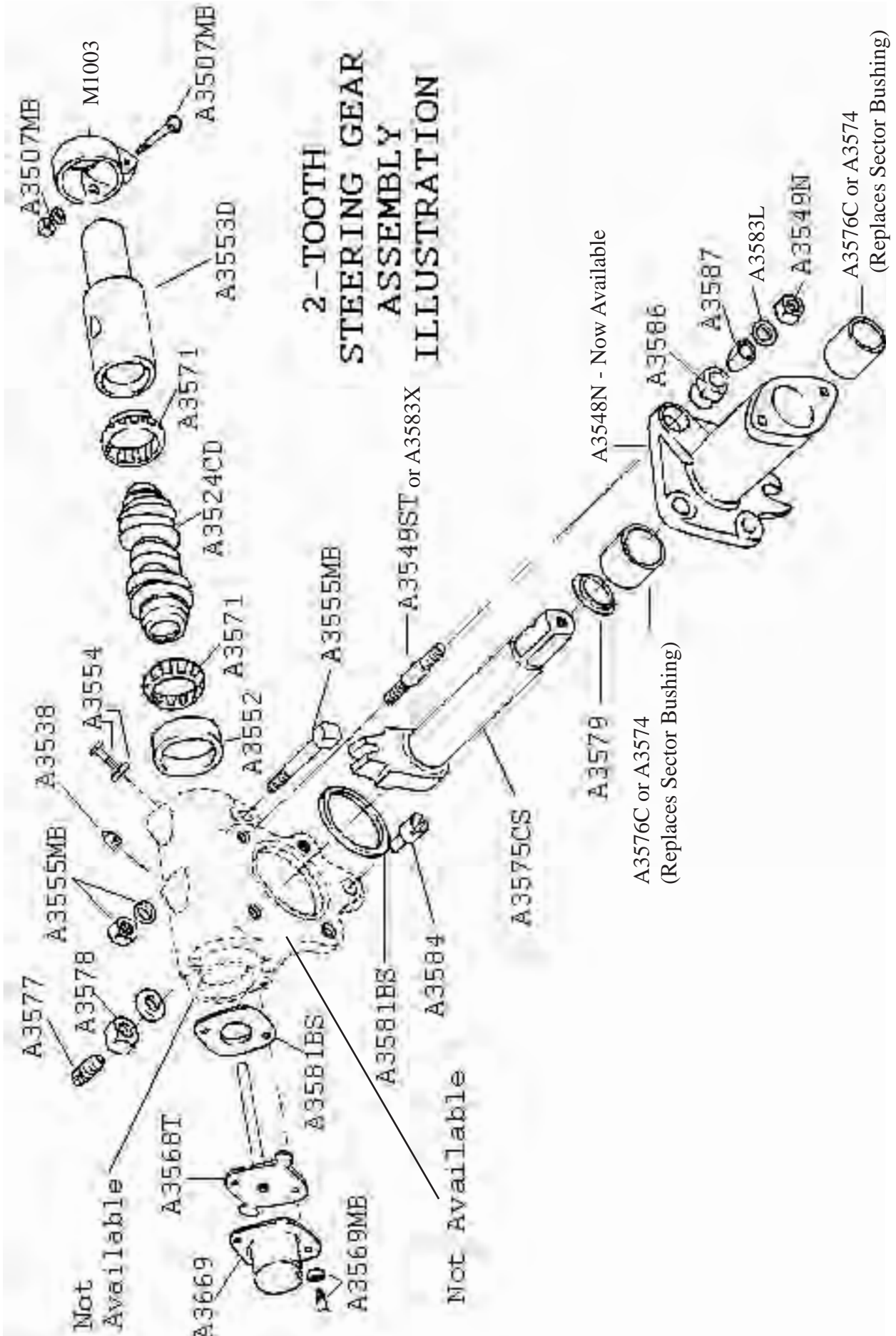

Mike's "A" FORD-ABLE Parts

STEERING

Steering Housing to Frame Bolts

This 4 pc. set holds the steering box to the frame rail.

Nut must be outside of frame.

Cross Drilled for cotter pins.

2 x 7/16"-20 x 1 5/32 - Castle nuts.

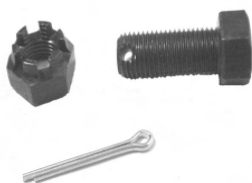

A3547MB 28-31 Price Set/4 \$ 5.35

Needle Bearing Housing

New and Rebuilt now available with needle bearings and seals, ready to install. 2 Tooth only.



A3548 REBUILT Jan. '29-'31 Price Ea. \$ 77.00
 A3548CO Refundable Core Charge Price Ea. \$ 30.00

Steering Lower Bearing Cup

Used on the 2 tooth sector on the lower steering worm. To remove cup, slide a punch through the two bolt holes in the bottom of the housing, and tap out the cap.



A3552 29-31 Price Ea. \$ 10.35

Race Driver Tool

Use this tool to install the A3552 bearing in the bottom of the box on your two tooth steering gear box.



T3552 29-31 Price Ea. \$ 38.95

Steering Gear Housing Bushing

Located above the worm. Used only on 7 tooth steering.



A3553AR 28-29 Price Ea. \$ 14.95

Steering Upper Race

For 2 tooth sector used after Jan '29. Check yours for cracks or pitting of the bearing surface.



A3553D 29-31 Price Ea. \$ 34.95

Steering Upper Race Bolt & Nut - Worm Adjusting Screw

This bolt with thin nut is used to adjust the upper race on the 2 tooth boxes.



A3554 29-32 7/16"-20 x 1 7/16" Bolt & Washer & Nut Price Set/3 \$ 3.25

Steering Clamping Bolt Kit

This is the nut, bolt, and washer needed to hold the upper race in place on the 2 tooth boxes.



3/8 - 24 x 1 - 15/16 Bolt & Lock Washer.

A3555MB 29-31 Price Set/3 \$ 0.75

Steering Shaft Felt Retainer

A special cupped washer that holds the felt in place. As you tighten the hex part of the retainer it will adjust the felt for a seal. Used on Seven Tooth Steering box.



A3527BR 28-29 Price Ea. \$ 4.75

Steering Shaft Retainer with Tube

This retainer has an oil tube added to prevent any gear box oil from dripping through to the wire harness. Seven Tooth Only.

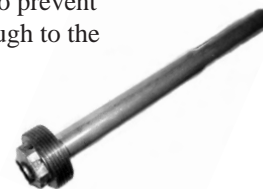

A3527T 28-29 Price Ea. \$ 10.25

Steering Gear End Plate

For 2 tooth steering gear assemblies. Replaces the end plate on the steering column and has a tube that goes above the oil level to avoid leaks.



A3568T 29-36 Price Ea. \$ 8.25

Steering Light Switch Bracket

Bolts to the bottom of the 2 tooth steering column; light switch body fits inside. Notch in sleeve faces down.



A3569 29-37 Price Ea. \$ 5.45

Mike's "A" FORD-ABLE Parts

STEERING

Steering Light Switch Bracket Bolts

For earlier A's with 4 bolt light switch mounting plate at the end of the steering column.
4 1/4 - 28 x 21/32 & L.W's.

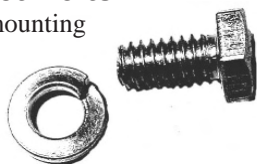

A3569AMB 28-29 4 Bolts & 4 Washers
Price Set/8 \$ 0.95

Steering Light Switch Bracket Bolts

For later as with 2 bolt light switch bracket.
2 x 1/4" - 20 x 5/8" bolts and L.W.



A3569MB 29-31 2 bolt. Price Set/4 \$ 0.70

King Pin & Steering Worm Bearing

For 7 tooth steering worm, 2 needed.
Timken are not always available.



A3123 USA Made Price Ea. \$ 3.00



2 Tooth, 2 Needed.

A3571 29-31 2 tooth Price Ea. \$ 8.40

Steering Needle Bearing Set

Replaces the bushings in the sector housing to make steering smoother. Bore out each end of the sector gear housing 1 1/8" deep and 1 3/8" diameter. Put needle bearing in each end. Kit includes the following: 2 Needle Bearings, 2 O-rings.



A3574 29-31 Price Set/6 \$ 21.80

Spare "O" Ring

A spare O Ring for the Steering Needle Bearing.



A3575O Price Ea. \$ 2.65

Steering 2 tooth Sector

Foreign made - Best Available for later 2 tooth style. The SIDES should touch the worm, not tip of the teeth.



A3575CS 29-31 Price Ea. \$ 89.95
A3575-CRH Right Hand Drive Price Ea. \$ 85.00

Steering 7 tooth Sector

Foreign made - Best Available - does a good job. For early 7 tooth style.



A3575B 28-29 Price Ea. \$ 75.00
A3575-BRH Right Hand Drive Price Ea. \$ 89.50

Steering Sector to Frame Seal - 7 Tooth Sector

Bore the end of the sector that bolts to the frame .150 deep and 1.375 diameter to install seal.



A3549A 28-29 Price Ea. \$ 3.25

Steering Sector to Frame Seal - 2 Tooth Seal

Bore the end of the sector that bolts to the frame .250 deep and 1.625 diameter to install seal. Press in the neoprene seal to stop the oil from dripping out of the sector. This seal is an after market improvement. Included with A3548 on Page 74.



A3549B 29-31 Price Ea. \$ 6.45

Steering Sector Bushings

Two bushings fit in the housing where sector goes through. Need 2.



A3576C 28-31 Ream to 1.125" Price Pair \$ 3.95

Steering Sector Thrust Screw

Used to adjust end play on the sector shaft on 7 tooth models. Use the A3578 for Lock Nut - see Page 76.



A3577R 28-29 7 tooth 1/2" - 20 x 1" Price Ea. \$ 2.75

Used to adjust sector end play on 2 tooth models. You will need A3578 on Page 76 with A3577.



A3577 29-31 2 tooth 9/16" - 18 x 15/16" screw Price Ea. \$ 2.75

Order online at www.mikes-afordable.com and get a 5% discount!!

Gen.75

Mike's "A" FORD-ABLE Parts

STEERING

Steering Jam Nut

This is a thin nut to lock the sector thrust screw in place on the side of the steering column.



A3578 29-31 15/16" Price Ea. \$ 0.75

Steering Sector Thrust Washer

For 7 Tooth Only.



A3579AR 28-29 Ground & Hardened Price Ea. \$ 13.50

Special dish washer fits between sector and steering box on 2 tooth models. Raised center points toward Pitman arm end.



A3579 29-31 Price Ea. \$ 1.25

Steering Lower Bearing Bushing

7 Tooth Only. Brass bushings at the end of the Seven Tooth steering Shaft. ID of bushing is .656



A3776C 28-29 Standard Price Ea. \$ 14.50

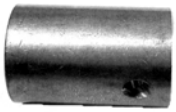

7 tooth steering only- If shaft is worn - turn it down and use under-size bushing. Turn shaft to 5/8". ID of bushing is .625

A3776CO 28-29 Oversize Price Ea. \$ 14.50

Steering Sector Cover Plate Bolt

Mike has these 3 bolts & lock washers that are used to hold the cover to the worm housing for the 7 tooth sector.



A3580MB 28-29 3 x 1/4" - 28 x 21/32" bolt & l.w. Price Set/6 \$ 1.00

Steering Housing Gasket Set

Complete gasket set for both 7-tooth and 2 tooth models.



A3581AS 28-29 7 tooth gear Price Set/7 \$ 2.50

A3581BS 29-31 2 tooth gear Price Set/3 \$ 2.25

Steering Sector Housing Cover Stud L/washer

This is a special 29/32 OD extra wide lockwasher that locks the housing to the gearbox.

The set includes 3 wide washers and a 4th regular size washer for the eccentric stud.



A3583L 29-31 Price Set/4 \$ 1.80

Steering Sector Housing Stud Nuts

Four original thick 3/8-24 hex nuts to secure the sector housing to the worm gear box.

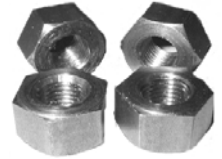

A3583N 29-31 Price Set/4 \$ 4.50

Steering Eccentric Rivet

This is riveted at the base of the steering column to adjust the sector housing for 2 tooth models.

A3584 29-31 Price Ea. \$ 2.95



Steering Sector Housing Studs

Three 3/8-16 x 3/8-24 x 1 7/16 studs per set. The fourth stud is a special shouldered stud. Order A3585 for the special fourth stud.

These are the correct length.

A3583X 29-31 Price Set/3 \$ 2.10



Steering Sector Adjustment Stud

This is the special stud that the eccentric sleeve (A3586 - Page 77) and the adjusting cone (A3587 - Page 77) mount on to adjust the 2 tooth Steering Sector.

A3585 29-31 Price Ea. \$ 3.50



Mike's "A" FORD-ABLE Parts

STEERING

Remember to only use 600 Weight Oil in your Steering Box.

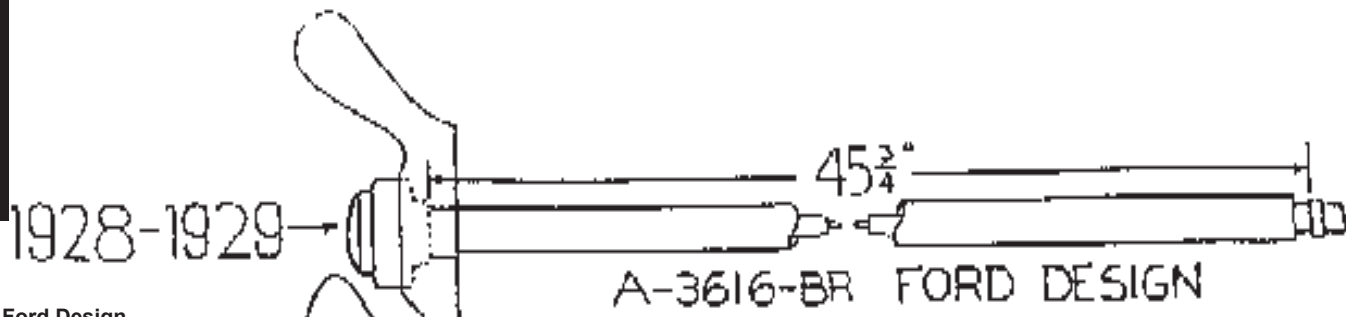

Ford Design -
1928 - March 1930
7 Tooth Box with 44 1/2" shaft
(even though the two-tooth gear
went into production in Feb. 1929
this one is correct through March
1930.

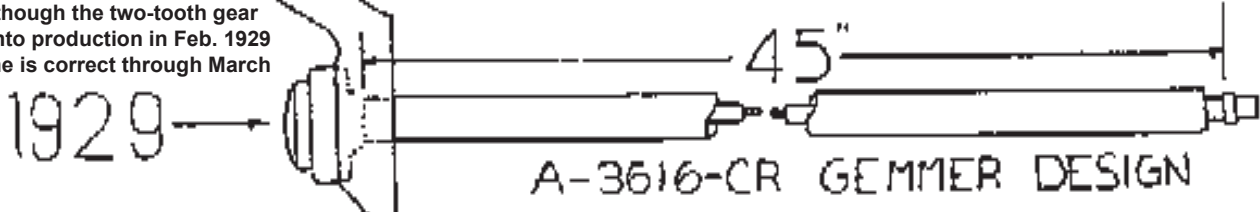

Gemmer Design
- Feb. 1929 - 1929
2 Tooth Box with
43" Shaft

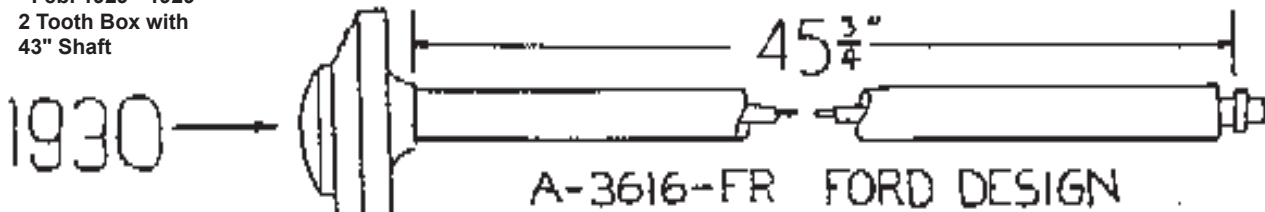

Ford Design
- Jan. 1930
- March 1930
7 Tooth Box
with 44 1/2"
Shaft

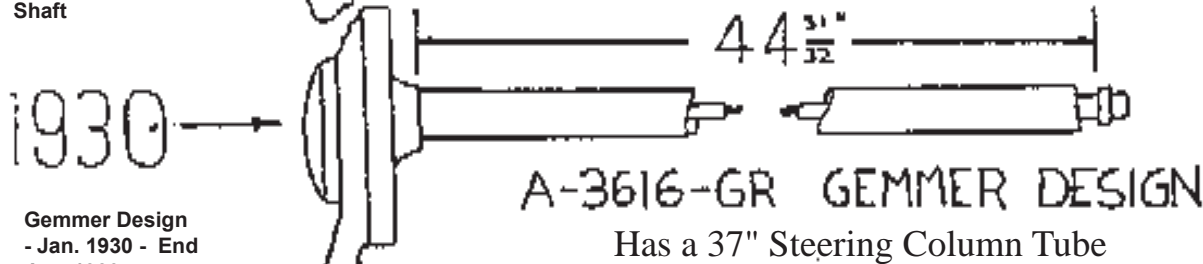

Gemmer Design
- Jan. 1930 - End
Jan. 1930
2 Tooth Box with
43" Shaft

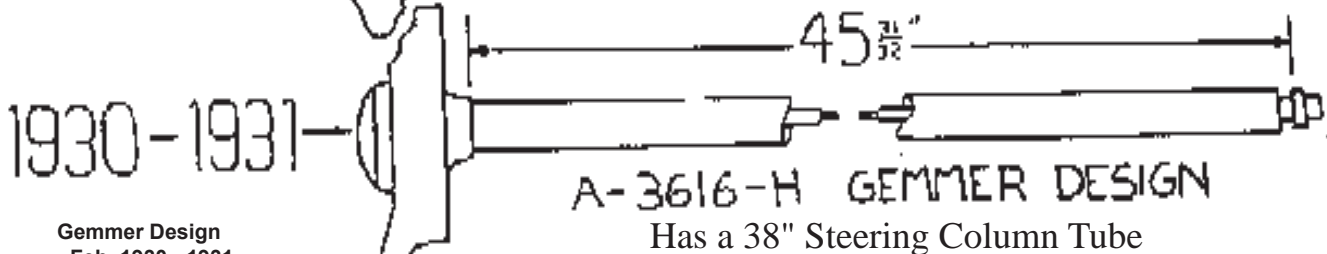

Gemmer Design
- Feb. 1930 - 1931
2 Tooth Box with
44" Shaft

Please refer to Page Gen. 79 for Steering Wheels

Mike's "A" FORD-ABLE Parts

STEERING

Steering Light Switch Spider

This goes on the end of the light switch rod that fits into the light switch body. Install the prongs at 6 and 12 o'clock on to the horn rod and the light switch lever at 6 o'clock.



A3643 28-39 Price Ea. \$ 3.25

Light Switch Spider Tool

Tape the horn button down with a piece of masking tape or have someone hold the button down for you. Now insert the light switch spider over the legs of the tool, slide the spring onto the spider and push them both onto the horn rod making sure you have the ears lined up correctly. Push far enough so you can install the retainer, then remove the tool and you have just installed the spider and retainer easily. The spring A3642, Spider A3643 and A3644 Retainer are sold separately.

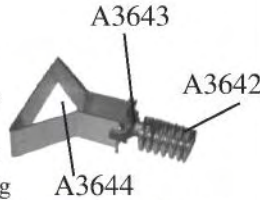

T3643 28-31 Price Ea. \$ 5.50

Steering Light Switch Spider Retainer

This U-shaped clip holds the light switch spider on the rod.



A3644 28-36 Price Ea. \$ 0.40

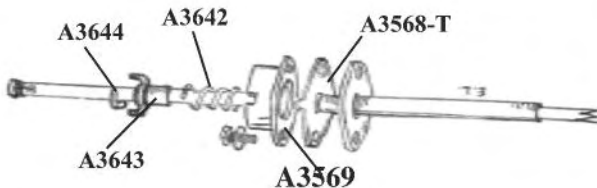

The correct order of assembly of the light switch rod is: spring, spider, clip and light switch body which holds the wiring assembly.

Steering Light Switch Bail

This holds the light switch body (A11655/67 - below) to the bottom of the steering column. Zinc plated.



A3647A 28-1931 Price Ea. \$ 1.75

Steering Light Switch Body

Best available. This mounts on the bottom of the steering column and the light wire slips inside to control the lights.



A11655/67 28-37 Price Ea. \$ 17.00

Light Switch Body Lower Half

The correct round shaped bottom for the lower Half of your Light Switch Body. Will fit the A11655/67 Repro's and original bodies. Short body - 1 7/8" Long.



A11655B 1928 - April 1930 Price Ea. \$ 13.05



Long Body - 2 1/8" Long.
A11655C April 1930 thru 1937 Price Ea. \$ 13.05

Splined Steering Wheels

Rust Red. In production until Feb '29. Splined hub - 7 Tooth Boxes



A3600A1	Early '28	Import - Red	Price Ea. \$ 105.00
A3600A1USA	Early '28	USA Made - Red	Price Ea. \$ 140.00
A3600BS	Sept. '28 - '29	USA Made - Black	Price Ea. \$ 140.00
A3600BS1	Sept. '28 - '29	Import - Black	Price Ea. \$ 102.00

Keyed Steering Wheel

For use on earliest 2 tooth sector boxes. Keyed hub. Jan. 1929 to Jan. 1930. Red used thru Feb. '29.



A3600BKR	28-29	USA - Red	Price Ea. \$ 140.00
A3600BK	1929 - 1930	Import - Black	Price Ea. \$ 99.00
A3600BKUSA	28-29	USA - Black	Price Ea. \$ 135.00

Keyed Steering Wheels

For use on '30-'31 Model A's with 2 tooth sector boxes. Keyed hub. Import.



A3600C	30-31	Import - Black	Price Ea. \$ 110.00
--------	-------	----------------	---------------------

PLEASE NOTE: A bit of Sanding and buffing will need to be done on the USA made steering wheels, where the two halves of the mold meet. The USA Wheels are detailed just as the originals were.

A3600USA	30-31	USA - Black	Price Ea. \$ 125.00
----------	-------	-------------	---------------------

Order online at www.mikes-afordable.com and get a 5% discount!!

Gen.79

Steering Wheel Puller

This helpful tool removes the steering wheel from the steering shaft. Contains 2 pulling plates. One for the '28-'29 Steering Wheel and the other for the '30-'31 Steering Wheel.

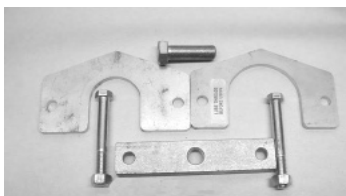

600P 28-31 Price Kit \$ 41.95

The removal of either Steering Column requires the following:

- Removal of Floorboards
- Removal of Brake & Clutch Pedals
- Disconnect Battery cable from the Starter Switch
- Remove Starter
- Disconnect Gas and Spark Rod
- Remove Light Switch Bail
- Remove Wire Assembly from bottom of the column.
- Remove Pitman Arm
- Remove the clamp and Anti Rattle rubber inside the car under the gas tank.
- Remove the entire column from inside of the car

PLEASE NOTE: Due to the lack of available 2 Tooth Steering housings, we must have your old 7 Tooth to Convert and an additional 2 Tooth Core will be needed. An additional \$75.00 will be charged if you do not have the 2 Tooth Core for the conversion.

******* MIKE'S TIPS *******

Only Use 600W Oil in your Steering Box. The 7 Tooth takes 7 3/4 Oz and the 2 Tooth takes 1 1/2 Oz. See Restoration Supplies Section - See Page 29.

Estimate for 7 Tooth to 2 Tooth Conversion - Parts & Labor

1	A3507MB	Steering Clamp Bolt	\$ 0.60
1	A3517B	Upper Bushing	\$ 9.25
1	A3524CD	Worm	\$ 53.95
1	A3538	Plug	\$ 0.50
2	A3540A Chrome	Spark & Gas Rods @ 16.00	\$ 32.00
1	A3540F	Spark & Gas Rod Anti-Rattler	\$ 0.70
2	A3541	Control Rod Arms @5.25	\$ 10.50
1	A3542	Control Rod Arm Pins - Pair	\$ 0.25
1	A3545	Control Rod Springs	\$ 0.75
1	A3583N	Nuts - Set	\$ 4.50
1	A3583X	Studs - Set	\$ 2.75
1	A3552	Worm Cup	\$ 10.35
1	A3553D	Upper Race	\$ 34.95
1	A3554	Upper Race Adj. Bolt Set	\$ 3.25
1	A3555MB	Clamping Bolt Set	\$ 0.75
1	A3568T	Seal Plate / Tube	\$ 8.25
1	A3569	Light Switch Bracket	\$ 5.45
1	A3569MB	Light Switch Bracket Screw Set	\$ 0.70
2	A3571	Worm Bearing @ 8.40	\$ 16.80
1	A3575CS	Sector	\$ 89.95
1	A3577	Sector Thrust Screw	\$ 2.75
1	A3578	Jam Nut	\$ 0.75
1	A3579	Sector Thrust Washer	\$ 1.25
1	A3548	Needle Bearing / Seal Setup -	\$ 43.95
1	A3581BS	Gasket Set	\$ 2.25
1	A3583L	Steering Sector Housing Cover Stud and Lockwasher	\$ 1.80
1	A3584	Steering Eccentric Rivet	\$ 2.95
1	A3585	Steering Sector Adjustment Stud	\$ 3.50
1	A3586	Eccentric Nut	\$ 2.50
1	A3587	Cone	\$ 2.50
1	A3609	Steering Wheel Woodruff Key	\$ 0.85
1	A3610	Steering Wheel Nut	\$ 0.50
1	A3616B,C,F,G OR H	Light Switch Rod	\$ 42.95
1	A3642	Spider Spring	\$ 0.65
1	A3643	Spider	\$ 3.25
1	A3644	Spider Retainer	\$ 0.40
		Total Parts	\$ 399.00

4 1/2 Hours Labor @ \$45.00 \$ 202.50

A3507SC Total 7 to 2 Tooth Steering Column Conversion on Exchange Only (With Core Received) Painted and ready to install Price Unit \$ 601.50

Mike's "A" FORD-ABLE Parts

Model A Ford Gemmer 2 tooth Steering Gear General Casting Identification by Dates of Production



STEERING

There are five different steering gear housing castings. They are:

1. February 1929 to May 1929: The words "GEMMER" and "PAT.PDG" in raised letters.
2. February 1929 to May 1929: The words "GEMMER" and "PAT. PEND" in indented letters.
3. April 1929 to mid 1930: The words "GEMMER" and "Patented" in indented letters.

NOTE 1: Each of the above castings had a large raised "F" on the engine side of the casting.

4. January 1930 through end of production: No identification except an indented "A-3550-C" on the engine side.
5. January 1930 through end of production: No identification except an indented "A-3550-C" on the engine side and a raised 5/16" or a 9/16" letter "F" on the outer side.

NOTE 2: Except for minor machining differences, all the above steering gear housings are virtually identical mechanically, and all new parts furnished will fit each one.

Source: Model A Judging Standards & Restoration Guidelines

PLEASE NOTE: We will not ship out our Rebuilt Steering Units until we have received yours in exchange, due to the fact that there are different shaft lengths we want to supply you with the correct item. Please send your Steering Box with Steering Shaft ONLY. (Unless you require your Steering column to be rebuilt as well.)

Wouldn't we all love to find this out in a "Field" somewhere. Well Mr. Field of Canton, GA did.



Order online at www.mikes-afordable.com and get a 5% discount!!

Gen.81

Mike's "A" FORD-ABLE Parts

STEERING

Estimate for Rebuilding your 2 - Tooth Steering Gear - Including Parts & Labor

1	A3524CD	Worm	\$ 53.95
1	A3538	Plug	\$ 0.50
1	A3583N	Nuts - Set	\$ 4.50
1	A3583X	Studs - Set	\$ 2.75
1	A3552	Worm Cup	\$ 10.35
1	A3553D	Upper Race	\$ 34.95
1	A3554	Upper Race - Adj. Bolt Set	\$ 3.25
1	A3555MB	Clamping Bolt Set	\$ 0.75
1	A3568T	Seal Plate / Tube	\$ 8.25
1	A3569	Light Switch Bracket	\$ 5.45
1	A3569MB	Light Switch Bracket Screw Set	\$ 0.70
2	A3571	Worm Bearing @\$8.40	\$ 16.80
1	A3575CS	Sector	\$ 89.95
1	A3577	Sector Thrust Screw	\$ 2.75
1	A3578	Jam Nut	\$ 0.75
1	A3579	Sector Thrust Washer	\$ 1.25
1	A3548	Needle Bearing / Seal Setup	\$ 43.95
1	A3581BS	Gasket Set	\$ 2.25
1	A3583L	Sector Housing Cover Stud L/Washer	\$ 1.80
1	A3584	Steering Eccentric Rivet	\$ 2.95
1	A3585	Sector Adjustment Stud	\$ 3.50
1	A3586	Eccentric Nut	\$ 2.50
1	A3587	Cone	\$ 2.50
1	A3609	Steering Wheel Woodruff Key	\$ 0.85
1	A3610	Steering Wheel Nut	\$ 0.50
Total Parts			\$ 297.70
2	Hours	Labor @ \$45.00	\$ 90.00
A3502SG	2 Tooth Steering Gear - Exchange ONLY		\$ 387.70

Estimate for Rebuilding Steering Column - Parts & Labor

1	A3517B	Upper Bushing	\$ 9.25
2	A3540 Chrome	Spark & Throttle Rods @\$18.50	\$ 37.00
1	A3540F	Spark & Gas Rod Anti Rattler	\$ 0.70
2	A3541	Control Rod Arm @\$ 5.25	\$ 10.50
1	A3542	Control Rod Arm Pins - Pair	\$ 0.25
1	A3545	Control Rod Springs	\$ 0.75
1	A3507MB	Steering Clamp Bolt	\$ 0.60
Total Parts			\$ 59.05
2	Hour	Labor @ \$45.00	\$ 90.00
A3502SC	Total Rebuilt Steering Column - Parts & Labor		\$ 149.05
A3502	Total Rebuilt Steering Gear and Steering Column on Exchange (with core - Received) Painted and ready to install		\$ 536.75

EXTRAS IF NECESSARY:

1	A3526	Steering Shaft Thread Repair (Rebuilt Broken / Bad Steering Shaft threads)	\$ 45.00
---	-------	--	----------

PLEASE NOTE: Unit is shipped dry. You need to add 600W oil to your order if you don't have a spare supply.

REAR END PARTS

Specifications:

Type:	Three quarter floating
Material	Special Ford carbon manganese steel
Gear ratio (gear teeth: ring pinion)	3.78:1 (34-9)
	Early '28's: 3.7:1 (37-10)
	Trucks: 4.11:1 (37-9)
	~ 10,000 28-29 Roadsters: 3.54:1 (39-11)
Pinion bearing	Double taper roller type
Bearing cup	Timken 28317
Bearing	Timken 28156
Ring gear	8.4" pitch diameter, 1-3/16" wide teeth
Axle shaft	1-1/8" diameter; 1.128 to 1.130" at wheel bearing
Dimension from housing flange to bearing shoulder in axle housing:	
Before 1929	1.370 to 1.372"
After 1929	1.365 to 1.367"
Rear wheel bearing	O.D. Of axle housing race 2.061 to 2.0635"
I.D. Of wheel hub	3.188 to 3.190" : Max wear 3.185"
Axle and drive shaft seal ...	CR 10926
Rear axle seal	CR 20112, Victor 49024
Differential lubricant	600W

***** MIKE'S TIPS *****

It is always a good idea to periodically check the internal parts of the rear end. After removing the rear spring, unbolt the drivers side axle housing, this will allow for the removal of both axles. To remove the axle with ring & pinion, you only need to remove the ten bolts on the driver side of the axle housing. Then slide off the housing and pull the axles with ring & pinion attached out. At this time, replace the 3 grease seals, 1 at either end of the axle housing and 1 at the front of the torque tube. Always use new gaskets and seals when replacing the housing. Soak your Gaskets in Hot water.

The following new parts are required to complete a restoration of your Rear End. This is only a guide - do not assume that this is all that is needed, all other parts need to be thoroughly checked and rebuilt if necessary. If rebuilding is something that you do not wish to do, all of the original parts can be rebuilt at Mike's "A" Ford-able Parts.

1. Rear Axle Gasket Set - A4035S
2. Rear Hub Pullers - T1114T, T4239 or T4239B

3. Universal Bushing Installation and Removal Tool - T3820/44T
4. Spring Spreader - Rear - T5301 or T5302
5. Drive Shaft key - A4606
6. Pinion Puller - T4210T
7. Ring & Pinion (3.78 to 1.) Standard - A4209 - (3.54 to 1.) High Speed - A4209HS
8. Differential Bearings A4221 and Cups A4222
9. Pinion Bearing Cup - A4616
10. Axle Keys - A4243 and Shims - A4235SH
11. Inner Axle and Drive Shaft Seals - A4245
12. Seal Driver - T4246
13. Pinion Nut Wrench - T4634T
14. Pinion Bearing Nut - Need 2 - A4634 and lock washer - A4636
15. Rear Shackle Kit - A5630 or A5715RE - USA
16. A600W for differential

Perch and Spring Bushings

For both the rear perches and rear leaf spring. Use 14.5 mm Ream to .571.

A4020 28-31 Need 8



Price Ea. \$ 0.95

Universal Bushing Installation & Removal Tool

An ideal Tool to remove bushings from Rear Brake Camshaft, Rear & Front Spring and Perch Bushings.



T3820/44T 28-31 Price Ea. \$ 10.95

Rear Perch Ball

Worn balls affect the shocks. This was a separate piece from Feb. '30. See Page 419 in Service Bulletins.

A4024 30-31

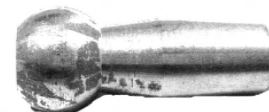

Price Ea. \$ 2.70

Differential Drain Plug

Doubles as both drain and filler plug. Need 2.

A4030 28-48



Price Ea. \$ 0.85

Rear Axle Housing Bolts

Productions of original thick headed bolts to secure the rear axle shaft housing to the differential housing. Torque to 35 Ft. Lbs.



035MB 28-31 20 x 3/8" - 24 x 5/8" bolts
Price Set/20 \$ 7.50

Permatex Prussian Blue

Used for precision fitting of valves, gears, bearings & most other machined surfaces. 3 Ounce Tube.



033 28-31 Price Ea. \$ 3.95

Rear Axle & U-Joint Gasket Set

9 piece gasket set for the rear axle and universal joints. Soak in hot water for a perfect fit.



035S 28-31 Price Set/9 \$ 4.75

Rear End Housing Gasket

2 piece gasket set for the rear end housing.

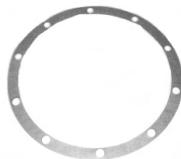

0235G 28-32 .010 Price Pair \$ 2.50
0236G 28-31 .006 Price Pair \$ 2.50

Torque Tube Gasket

Gasket for the torque tube with the groove.



0207 28-32 Price Ea. \$ 0.35

Standard Ratio Ring & Pinion

04 - Standard 3:78 to 1, all Model A's. See drawings on Page Gen. 87 & Gen. 88.

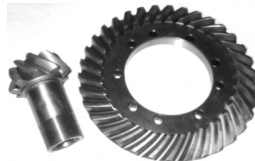

0209 28-32 Price Set/2 \$ 245.00

High Speed Ring & Pinion

039 - High speed 3:54 to 1, gears will add over 5 m.p.h. to your performance. Be sure you change your speedo gear - see car specific sections. See Drawings on Page Gen. 87 & Gen. 88.



0209HS 28-32 Price Set/2 \$ 289.00

Extra High Speed Ring & Pinion

11-37 3:27 Extra high Speed. For use on cars and light commercial vehicles. You will need a good strong engine to run this.



See our rebuilt Engines on Page Gen. 101 if you are needing a new one. 17 Tooth Ring - Don't forget to order the A17270C gear - listed in the Car Specific Sections.

A4209XHS 28-31 Price Set \$ 635.00

Overdrive Ring and Pinion

9-37 4:1:1 Gear Set. A new version ring and pinion available if you are running an overdrive. Lots of extra power. 21 Tooth.



A4209D 28-31 Price Set \$ 625.00

Pinion Puller

Don't risk damaging your drive shaft threads. Instructions Included.



T4210T 28-31 Price Set/5 \$ 38.50

Differential Spider Gears

Set of 3 Gears.



A4215 28-32 Price Set/3 \$ 125.00

***** MIKE'S TIPS *****

New Bearings Torque to 20 Inch Pounds
Bolts Torque to 35 Foot Pounds
Pinion Gear Backlash .005" - .010"
Axle Backlash .010" - .015"
Axle End Play .015" - .020"

Differential Bearings

A complete rebuild will require 4 of these Timken bearings. 2 in the differential plus 2 in the drive shaft.



A4221 28-32 Price Ea. \$ 36.00

Differential Bearing Cups

Two of these Timken cups are needed inside the differential.



A4222 28-32 Price Ea. \$ 19.90

Rear Axle Shims

These shims can tighten up a loose wheel due to worn hubs and also prevent the brake drum from rubbing on the backing plate.



A4235SH 09-48 Price Pair \$ 1.80

Mike's "A" FORD-ABLE Parts

Knock-Off Wheel Puller

To remove your hub from the axle, remove the axle nut and screw this long one on. Jack up the opposite wheel and hit this to break the hub free. This may not loosen rusted or very tight Hubs - Use **T1114T on Page 21** or **T4239 (below)** for this.



T4235WP **08-48** **Price Ea.** \$ **3.75**

Rear Hub Puller

An Economy style Hub Puller to do the job for you. Made from strong ductile Iron.

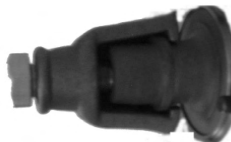

T4239A **1928 - Protruding** **Price Ea.** \$ **33.00**



T4239B **29-32 Recessed** **Price Ea.** \$ **33.00**

Rear Axle

This is a high quality USA reproduction made from forged alloy steel.



A4235A **28-32** **Price Each** \$ **350.00**

Rear Axle Nuts

Castle nuts for attaching rear hubs. **5/8 - 18**. Torque to 105 Ft. Lbs. Use **#37** or **#37SS** Cotter Pins - See **Page 34**. Need 1 Pair.



A4242 **28-48** **Price Pair** \$ **2.75**

Rear Axle Keys

Replace worn or broken axle keys. Tapered end towards differential. One used on each axle.



A4243 **28-48** **Price Pair** \$ **1.95**

Rear Axle Hub Gasket

Thick fiber washer which fits under the axle nut washer on the rear hub to prevent grease leaks. 1 on each hub.



A4244 **28-48** **Price Pair** \$ **0.55**

Rear Axle Washers

This steel washer acts as a buffer between the rear hub nut and the fiber washer **A4244**. Need 1 on each wheel.



A4244SW **28-31** **5/8" id. 1 1/4" o.d. 9/64" thick**
Price Pair \$ **1.00**

Inner Axle & Drive Shaft Seal

Keeps the grease in and the dirt out. Three are needed - 1 for each rear axle plus 1 for the drive shaft. Need 3. Tapered or sharp edge of rubber to face the differential.



A4245 **28-48** **Price Ea.** \$ **2.25**

***** MIKE'S TIPS *****

Fit the seals by placing the back or open side towards the lubrication, it will work either way, but this is the better way to go.

Economy Seal Driver

An inexpensive tool to install the axle seals. Inside is threaded to screw your own pipe on.



T4246 **28-48** **1/2" Pipe** **Price Ea.** \$ **7.00**

***** MIKE'S TIPS *****

For removal of the roller bearing race and seal, place a 1 1/16" 6 point socket over the splined end of the drive shaft. Insert the end with the socket into the differential end of the torque tube. Slide it all the way up the tube. Bounce the torque tube a few times. The socket pressing against the seal will force the seal and the race out.

Torque Tube to Differential Housing Bolts

Set of bolts with drilled heads for safety wire to mount the torque tube to the differential housing.

Safety wire included.

Torque to 35 Ft. Lbs.

See **Page 29** for additional Safety Wire.

A4505MB **28-31** **6 3/8" - 24 x 3/4"**
Price Set/7 \$ **7.50**



Universal Gasket Set

Quality felt gasket set for the universal joint. 2 Round and 2 felt gaskets.



A4515GS **28-31** **Price Set/4** \$ **2.25**

Universal Joint Bolt Set

Set of bolts, nuts and cotter pins to assemble the universal joint housing caps. Cars before **Mid '28**, used

4 Nuts, bolts and L/w's. This is a 24 Piece set.

Contents as follows:

6 - 3/8-24 x 1 7/32

6 - Castle Nuts

6 - Cotter Pins

2 - 3/8-24 x 1

2 - Nuts

2 - Lock Washers.

A4520MB **Mid 28- till end 31** **Price Set/24** \$ **9.00**



Mike's "A" FORD-ABLE Parts

New Drive Shaft

High quality drive shaft for the A.



A4605B 28-31 Price Ea. \$ 235.00

Drive Shaft Key



A4606 28-31 Price Ea. \$ 0.85

Drive Shaft Nut

This special short Castle Nut holds the Pinion Gear to the Drive Shaft. 5/8 - 18.



A4605MB 28-31 Price Ea. \$ 2.95

Pinion Bearing Cup

Timken brand double-sided cup for the pinion bearings. Replace yours if it is pitted, cracked or scored.



A4616 28-32 Price Ea. \$ 44.25

Pinion Bearing Nut

This large nut is used to set the pre-load on the two pinion bearings. Need two.



A4634 28-32 Price Ea. \$ 3.25

Pinion Nut Wrench

High quality steel wrench with good design to install/remove the pinion nut. Need 2 wrenches to hold lock nuts.



T4634T 28-32 Price Ea. \$ 16.95

Pinion Lock Washer

This nut is especially designed to bend around the pinion bearing nut. Should always be replaced when you disassemble the pinion bearing.



A4636 28-48 Price Ea. \$ 1.50

Pinion Bearing Thrust Washer

Positioned behind the pinion nut.



A4637 28-31 Price Ea. \$ 1.95

Torque Tube Drive Shaft Bearing

This is the bearing at the front of the drive shaft.



A4645 28-48 Price Ea. \$ 10.00

Torque Tube Bearing Sleeve

This sleeve aligns the drive shaft bearing in the front of the torque tube. Has dimple as original for lineup.



A4655 28-48 Price Ea. \$ 7.85

Speedometer Snap Ring

This snap ring holds the speedometer drive gear and thrust washer in place on the drive shaft.



A17286 28-37 Price Ea. \$ 0.75

Speedometer Thrust Washer

The thrust washer goes onto the drive shaft between the bearing and the speedometer drive gear.



A17290 28-48 Price Ea. \$ 1.95

Radius Rod To Torque Tube Mounting Bolt

Set of bolt, nut and cotter pin to attach the rear radius rods to the torque tube. Cross drilled for cotter pins.



A4750MB 28-31 1 9/16 - 18 x 3 1/8 bolt and castle nut and cotter pin.

Price Set/2 \$ 2.50

Differential Hardware Kit (Exposed)

This set has all the exposed hardware needed to refurbish the differential. 20 Bolts, Lockwashers and 2 Plugs.



#41 28-31 Price Set/42 \$ 5.75

600-W Oil (With Pour Spout)

This is extra heavyweight oil you'll need for the rear end, the transmission, and the steering box. The rear end takes 1 1/2 Pints; the transmission, 1 Pint; and the steering box 7 3/4 ozs.



A600W 28-31 1 Quart Price Ea. \$ 9.95

REAR END PARTS

Gen.86

Give us a call -1-888-TRY-MIKE (879-6453)

Have an "A" Day!

Mike's "A" FORD-ABLE Parts

Removing Carrier and Axle Assembly

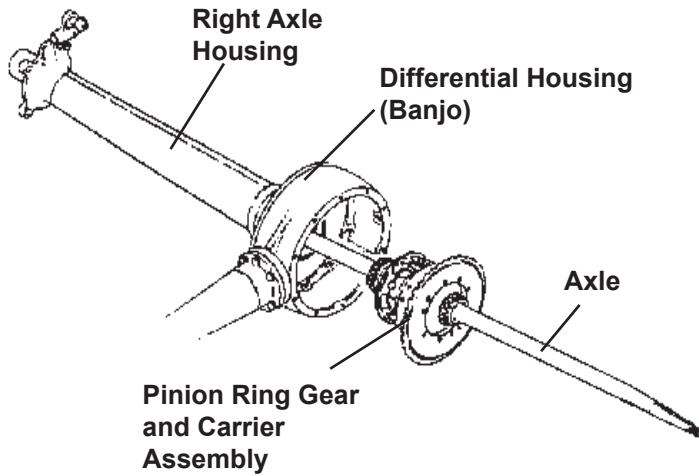

Split Carrier Assembly

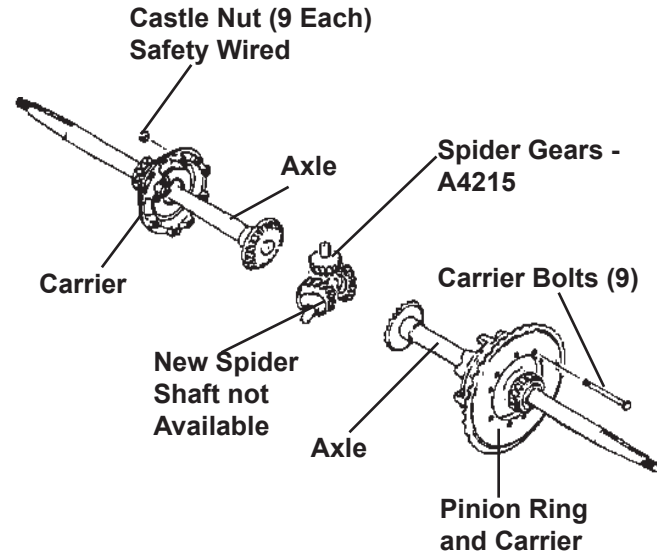

REAR END PARTS

Thanks to Les Andrews for the use of his drawings.

NOTE: To remove the axle with ring & pinion, you only need to remove the ten bolts on the driver side of the axle housing. Then slide off the housing and pull the axles with ring and pinion attached out.

Torque Tube / Speedo Gear Assembly

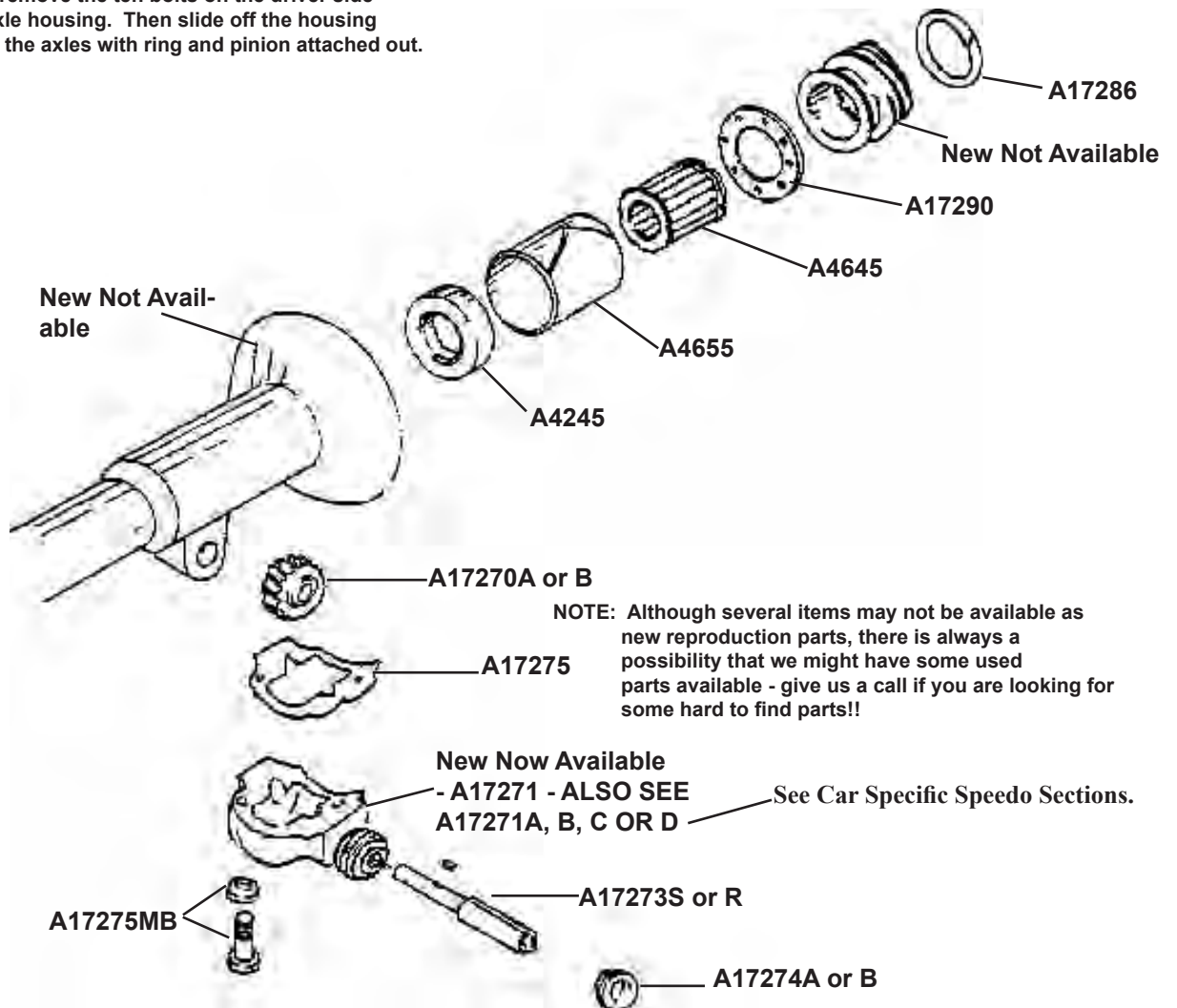

NOTE: Although several items may not be available as new reproduction parts, there is always a possibility that we might have some used parts available - give us a call if you are looking for some hard to find parts!!

Order online at www.mikes-afordable.com and get a 5% discount!!

Gen.87

Mike's "A" FORD-ABLE Parts

Rear End Drive Assembly

REAR END PARTS

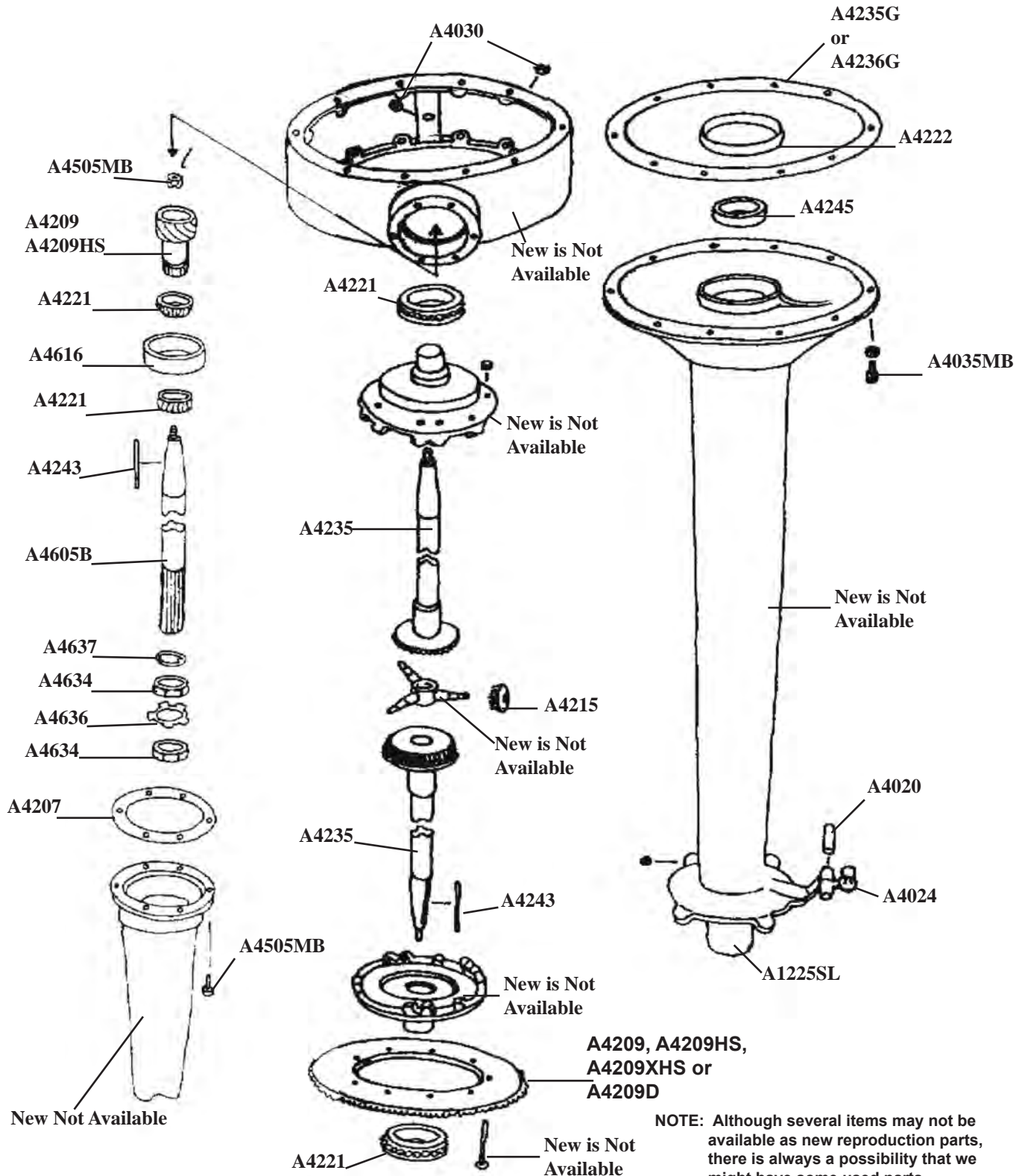

NOTE: Although several items may not be available as new reproduction parts, there is always a possibility that we might have some used parts available - give us a call if you are looking for some hard to find parts!!

FRAME AND MOUNTING

Removal of the body from the frame. The actual removal of the body is not as complicated as it seems. The average body weighs between 300lbs for Roadsters and up to 600lbs for Fordors. Only when the body is off can a complete restoration begin. Make sure that all of the weight, e.g., seats, floorboards, etc. are removed to lighten the body. Once the body is removed, this is the ideal time to work on the engine and all mechanical parts. You can also do any metal work that is needed on the body, which you have now placed on saw horses or stands. Make sure that you have a stand under the center of the body to minimize any door sag.

The following parts should be removed or disconnected before lifting off the body: The Gearshift, Emergency Brake Handle, Steering Column, all Gas Lines and Wiring, Radiator Support Rods, Hood, Rear Fenders, Bumper Arms to Body, Choke Rod and all body bolts.

***** MIKE'S TIPS *****

If you are having a problem with your Doors, or your Hood will not line up with your Radiator Shell and Cowl - additional Shimming is required, usually under the cowl section. Align the hood first, then work back.

Body Block Pads

These rubber pads are nailed to the Body Mount blocks to align the doors and hood.

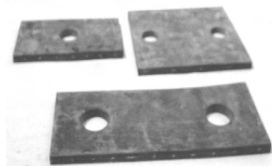

A5000P	28-29	Price Set	\$ 9.60
A5001P	30-31	Price Set	\$ 6.60

Cowl Shim Set

This set of round rubber shims go under the front of the cowl to align doors.



A5002P	28-31	Price Set	\$ 2.55
--------	-------	-----------	---------

Frame Welt

This high grade welt is treated to prevent rot.

One roll is enough for your car.



A3407X	28-31	Price Roll	\$ 16.50
--------	-------	------------	----------

Frame Horns

Replace bent horns with new ones, you must drill holes, sold in pairs only.



A5005CH	28-31	Price Pair	\$ 55.00
---------	-------	------------	----------

Rear Motor Mounting Bolt Set

Complete set of bolts, nuts, spacers and cotter pins to attach rear motor mount pads. Nuts go on outside of frame.

6 5/16-24 x 1 3/8 Bolts, 6 Spacers & 6 Castle Nuts.



A5092BS	28-31	Price Set/24	\$ 6.50
---------	-------	--------------	---------

Rear Mount Plates

This plate fits on the mounting pads outside the frame.

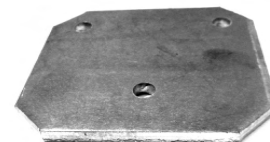

A5095A	28-31	Price Each	\$ 2.60
--------	-------	------------	---------

Rear Motor Mount Pads

High grade rubber pads for the rear motor mount.

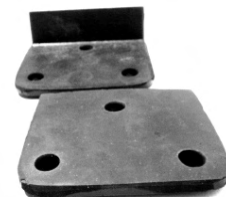

A5092-94	28-31	Price Set	\$ 7.95
A5092	Flat Pad Only	Price Ea.	\$ 2.00

Rear Float-A-Motor Kit

This special kit puts the rear of the engine on rubber to absorb vibration and give a smoother ride. Predrilled to fit right. Rubber Pad A5092 must be used on the outside of the frame (included in the kit).

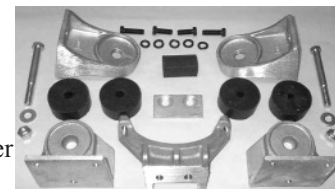

A5089FAM	28-31	Price Set	\$ 65.00
----------	-------	-----------	----------

Mike's "A" FORD-ABLE Parts

Rear Float-A-Motor Rubber Set

This is a set of replacement rubber for the float-a-motor kit.

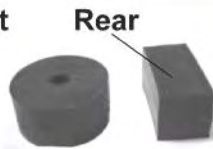

A5089R	28-31	Price Set/5	\$ 10.95
A5089S	Rear Piece Only	Price Ea.	\$ 1.50

Rear Float-A-Motor Mount Instructions

1. Put jack under flywheel housing and raise engine enough to take the weight off of the mounts.
2. Remove the three bolts, nuts, and spacers that hold the engine mount to frame.
3. Remove the two bolts that hold the mount on flywheel housing.
4. Remove front body mounting bolts, and knock the motor mount backward towards the transmission.
5. Jack up engine about one inch. Using your old motor mount bolts, plate and new outside pad **A5092**, you can attach the frame bracket. Place angle bracket with the taper towards the front of the car against frame and bolt in place. Do not use spacers. Don't forget to use the **A5092** pad and steel plate on outside of frame rail Only. Not on inside of the frame.
6. Attach two hole mounting bracket to flywheel housing. Be sure to bolt this piece in properly, as there is a top and bottom to it. The word 'TOP' is cast into the top side.
7. Install a rubber biscuit between the frame bracket and the flywheel housing bracket that you have just installed and let the motor down. Now install another biscuit on top of the flywheel housing bracket with the aluminum disc and drop long bolt down through center with the self locking nut. Tighten until biscuits are just starting to compress. Do not overtighten. Replace front body mounting bolt & nut.

Front Float-A-Motor Kit

If you need a smoother running engine with less vibration, this is just what you need. It mounts to the crossmember on two rubber mounts, can be installed with hood and radiator on. Two holes are needed to be drilled on the crossmember - ideal if front crossmember center hole is worn out. It saves you from replacing the crossmember.



A6031FAM	28-31	Price Set/11	\$ 65.00
-----------------	--------------	---------------------	-----------------

Rear Engine Mount to Flywheel Housing Bolts

This complete bolt and washer set connects the rear motor mount to the flywheel housing. Drilled for safety wire.

For Safety Wire see Page Gen. 29.



A5090MB	28-31 4 - 1/2" - 13 x 1 3/8" bolts	Price Set/8	\$ 3.25
----------------	---	--------------------	----------------

Frame Bracket

The front of the body attached to this. Bracket needs to be riveted to the frame. Use Rivets **RA1004**.

For Rivets and Tools see Pages Gen. 27 & Gen. 28.



A5075	28-31	Price Ea.	\$ 28.75
--------------	--------------	------------------	-----------------

Frame Bracket

The rear hood clip attaches to this. Bracket needs to be riveted to the frame. Use Rivets **RA1004**. For Rivets and Tools see Pages Gen. 27 & Gen. 28.



A5100	28-31	Price Ea.	\$ 21.75
--------------	--------------	------------------	-----------------

Running Board Bracket Mounting Kit

This set of 12 each bolts, nuts and lock washers can be used to mount the running board bracket to the frame. Originally the brackets were riveted in place. See **RA1003** on page Gen. 208.

12 x 5/16 x 18 x 1" L/w and nuts



A5125MB	28-31	Price Set/36	\$ 3.50
----------------	--------------	---------------------	----------------

Running Board Bracket Rivets

For the purist, a complete set of rivets to mount the running board bracket to the frame.

10 5/16 x 5/8 Round Head & 2 5/16 x 3/4 -

Heat Red Hot and Peen.

See Page Gen. 27 & Gen. 28 for Rivet Tools



RA1003	28-31	Price Set/12	\$ 6.75
---------------	--------------	---------------------	----------------

Running Board Brackets

These are the brackets that attach to the frame to support the running board.



See page Gen. 206 for Running Board items.

A5125A	28-31	Front Right/Left	Price Ea.	\$ 22.00
A5130A	28-31	Rear Left	Price Ea.	\$ 22.00
A5130B	28-31	Rear Right	Price Ea.	\$ 22.00

Running Board Bracket Anti-Squeak Welt

Place this thin 1/16" anti-squeak material on top of each brace before setting on the running boards. 4' Long x 1/16" x 3/4" woven treated fabric.



A5135	28-31	Price Roll	\$ 2.25
--------------	--------------	-------------------	----------------

FRAME & MOUNTING

BATTERY PARTS

Specifications:

Terminal grounded:	Positive
Voltage:	6 Volt
Capacity	80 amp hours, starting capacity 98 amps
Number of cells:	3
Number of plates:	13 per cell
Charging rate:	10 to 12 amps

Interstate Optima Battery

Excellent quality spiral cell Battery, with 750 cca, 104 minute reserve. Sealed Unit. Battery is placed on an angle into **A5151PC** and you must use the **A5166OP** to hold it down. Can be shipped by UPS.



A5150B **28-31** **Price Ea.** **\$ 147.95**

Battery Hold Down Bracket

A high quality powder coated steel bracket that holds the Optima Battery **A5150B** in place in a standard Model A Battery Frame.



A5166OP **28-31** **Price Ea.** **\$ 22.10**

Interstate Battery - 6 Volt Heavy Duty

Commercial 6 Volt Heavy Duty Battery. 575 cca, 160 minute reserve. **These cannot be shipped,** must be picked up in our store. Local Sales tax will apply. There is a \$3.00 core charge if a core is not available.



A5150C **28-31** **Price Ea.** **\$ 70.95**

Battery Maintainer

Keep your battery at peak performance. Use this to maintain a good battery at full charge. Not to be confused with a battery charger. A low voltage is sent to the battery until it's fully charged, then cuts off until the battery starts to lose some charge, at which time it will automatically cut back on to bring up the battery. This unit is safe and can be left unattended on the battery for months. Lamp flashes when battery is fully charged. Red positive, black ground.



A5150M **6 & 12 Volt** **Price Kit** **\$ 62.95**

Battery Box Support

A well-made reproduction complete with Support Studs **A5154** and Bottom Plate **A5151BPB**.

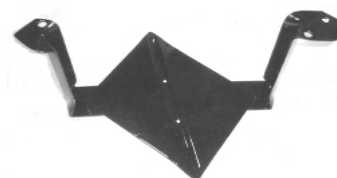

A5151PC **Powder Coated** **Price Ea.** **\$ 20.80**

Battery Box Bolts & Nuts

This is a 9 piece set of to secure the Battery Box to the Frame.

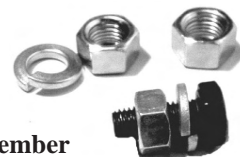

1 x 5/16-24 11/16 Bolt, L.W & Nut
1 x 3/8-24 Nut for Stud to Body X Member
2 x 3/8-24 Nuts & L.W. for Battery Frame Studs
A5151X **28-31**

Price Set/9 **\$ 1.20**

Battery Box Support Stud Set

This replacement set of studs, washers and nuts connect the battery hold down unit to the frame.

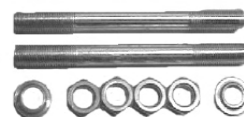

A5154 **28-31** **Price Set** **\$ 3.95**

Battery Box Hold Down Clamps (cast) 1928

Original style clamps that hold the 2 Corners of the battery to the box.

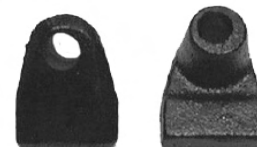

A5163A **1928 - Aug. '28** **Price Pair** **\$ 6.95**

Battery Box Hold Down Clamps

This is a reproduction of the corner clamps Ford used from **May '29** until end of production. Stamped Steel.



A5163B **May '29-end of '31** **Price Pair** **\$ 3.95**

Battery Box Hold Down Frame

This is a good reproduction of the frame Ford used. This is a more secure unit than **A5163B** Used from **Aug. '28 - May '29**. Powder Coated.



A5163FRPC **28-29** **Price Ea.** **\$ 10.95**

BATTERY PARTS

Battery Box Bottom Plate

If your battery frame is still good but the bottom has rusted out, replace it by welding a new plate to the frame. Ford prints called for the first two style plates to be trimmed straight, but not the last style. When the die strikes the plate to make the groove, the metal pulls, causing the sides to draw in 1/8" in some areas. Die stamped copies, made from Ford prints.

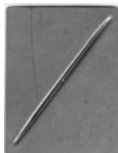

A square plate with one drain hole was used in
A5151BPA **1928 - Mid 1929** **Price Ea.** \$ **6.75**

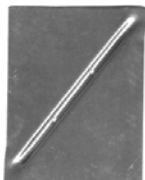

A Square plate with two drain holes was used in **Mid 1929 - 1930.**
A5151BPB **Mid 1929 - 1930** **Price Ea.** \$ **6.75**



A Square plate with two drain holes and clipped corners was used in **1931.**
A5151BPC **1931** **Price Ea.** \$ **3.25**

**See Page Gen. 93 & Gen. 94 for Battery
Cover Plates and Floorboards.**

BATTERY PARTS

FLOORBOARDS & MATS

Floorboard Screws & Washers

Black oxide screws and washers to mount the floorboards. 12 x 12/24 x 1 1/4" Flat Head Screws and Washers. For the Tudor Screws see the Tudor Section Page Sedan 47.



#33C 28-31 Price Set/24 \$ 2.50

Washers Only

A special countersunk washer used when mounting the floorboards. These washers are also used on some of the door hinges.



#109W Price Ea. \$ 0.12

Floorboards

These floorboards are made of exterior plywood and are cut and drilled for mounting. For Tudor Rear boards see the Tudor Section Page Sedan 47.

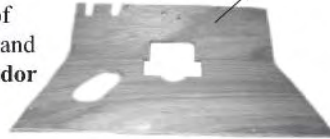

Emergency handle to front of gearshift.
AWD1251 28-29 Price Set/2 \$ 47.50

Emergency handle to right of gearshift.
AWD1252 30-31 Price Set/2 \$ 47.50

Floor Seal - A35130S or S2

Floorboard - See above

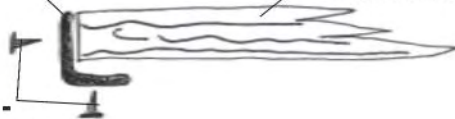

Tacks - A38425MBR

Floorboard Reinforcing Irons

These strips of iron were riveted to the bottom of the floorboard to support the middle of the floorboard. Rivets are Included.



RAR206 1928 AR Price Set/4 \$ 37.00

A35131 28-31 Price Pair \$ 19.45

Floorboard Reinforcing Iron Rivets

Eight 3/16 x 1/16 large 1/2" diameter tubular rivet that attaches the reinforcing Irons to the floorboards.



A35157 28-31 Price Set/8 \$ 1.25

Floorboard Pedal Pad

1928 to Nov. 1928 used this 6" x 8" Diamond patterned Rubber pad.



A35122AR 1928 Price Ea. \$ 59.95

RHD Floorboard Pedal Pad

If you are restoring a right hand drive car, you will need to use this rubber seal around the pedals and the steering column.



A35122RHD 28-31 Price Ea. \$ 51.95

Floorboard Pedal Plates

This 2 piece steel plate holds the felt in place around the pedals and steering column to keep air and fumes out. For the deluxe plates see the car specific sections.



A35123SP 28-31 Price Ea. \$ 5.75

Floorboard Plate Mounting Screws

Use this set to attach the pedal plates (A35122AR, A35122S or A35123BR). 2 x 12/24 x 1/2" Machine Screws with #10 Oval Head 1 #6 x 3/4" Oval Head Wood Screw and 3 Cup Washers.



A35123MB 28-31 Price Set/6 \$ 0.95

Floorboard Pedal Plate Felt Pad

This heavy felt pad fits tightly around the steering column and the pedals when used with the A35123SP above or A35123BR (page Spec. 35) metal plate.

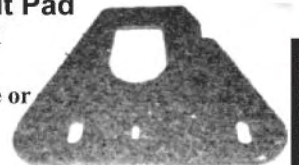

A35123FP 28-31 Price Ea. \$ 2.35

Mike's "A" FORD-ABLE Parts

Floorboard Seal

This black cotton webbing with tacks goes around the edge of the floorboard to seal out air and fumes. Tack to outside edge, then fold under the board and tack again for a tight seal. For the **Tudor** rear and center seal see the **Tudor** Section - Page Sedan 47.



A35130S 28-31 Price Set \$ 4.50

Accelerator Rod Grommet

This grommet is just like the original round rubber pad with tacks to seal out air and fumes from around the accelerator rod. 5 Piece Set.

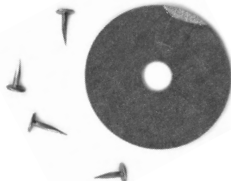

A35244 28-31 Price Set \$ 1.00

Shift Lever Plate Clips

Make removing floorboards easier by using this kit to remove the shift plate first. Attach and twist and it's done. Rivets and washers included. Use Tool **RA2022** - See Page Gen. 28. **3 x 3/16 x 15/16 Tubular Rivets with 1/2" Truss Head.**

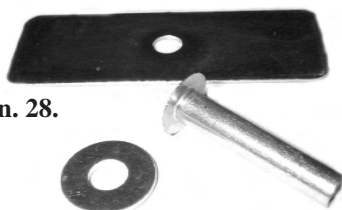

A35245C 28-31 Price Set / 9 \$ 2.50

Shift Lever Plate

This shift lever plate is for the '28-'30 A's with the emergency brake handle in front of the gear shift lever.

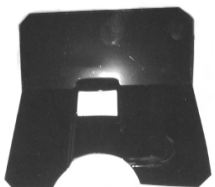

A35245A 28-30 Price Ea. \$ 3.90

Shift Lever Plate

This shift lever plate is for the '30-'31's with the emergency brake handle to the right of the gear shift lever.

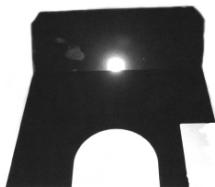

A35245B 30-31 Price Ea. \$ 3.90

Battery Cover Plate (Powder Coated)

This cover plate goes over the hole in the floorboard where the battery sits.

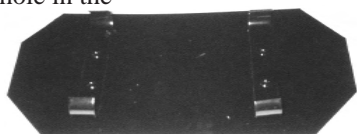

A35150APC 28-29 4-1/8" wide Price Ea. \$ 8.50

A35150BPC 30-31 5-1/4" wide Price Ea. \$ 8.50

Clutch Inspection Plate

Early '28's with the Emergency brake to the left had this plate installed in the floorboards to allow access to grease the clutch release bearing.



RAR230 1928 Price Ea. \$ 15.50

Kick Panel Retaining Clip

These clips hold the bottom of the kick panel snug.

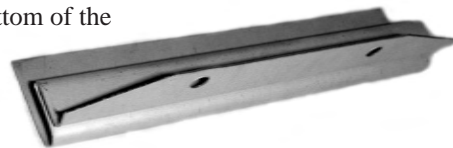

A40555CL 28-31 Price Pair \$ 5.75

Floor Mat Studs

This is a set of 4 of the special studs Ford used to hold the floor mats in place. 4 are needed for the firewall and 4 for the rumble. 8 Piece Set.



A2057MB 28-31 Price Set / 8 \$ 5.65

Floor Mats - Front Mats

These are the original, authentic design. From **June 1928** through **June 1929**, the hand brake lever was in front of the gear shift. **July 1929** till the end of production, the hand brake was to the right of the shift lever.

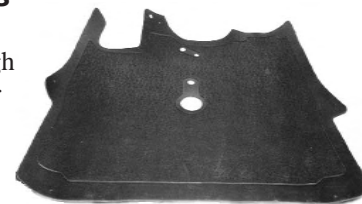

A2057 Brake to Front Price Ea. \$ 37.50

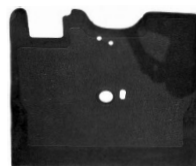

A2058 Brake to Right Price Ea. \$ 35.50

For Floor Mats for the rear of the Tudor and Rumble Seats see the Car Specific Categories.

Give Mike a call if Right Hand Drive Front Mats are needed - occasionally they are available!!

MUFFLER

Specifications:

Exhaust pipe: 2" I.D.
 Tail pipe: 1-5/8" I.D.

***** MIKE'S TIPS *****

Put a jack at the forward end, and just where it starts to bend up towards the exhaust manifold. Loosely fasten the tail pipe to the rear clamp, then screw your jack up until it presses the muffler against your exhaust manifold. Install your seal and tighten your clamp.

Muffler Heat Deflector

This heat deflector bolts to your exhaust to redirect heat away from your floor. Includes Clamps.

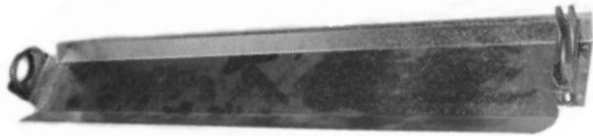

A5230HS	28-31	Price Set	\$ 24.00
A5230HSS	28-31 Stainless	Price Set	\$ 34.95

ADDITIONAL SHIPPING WILL APPLY TO ALL MUFFLERS DUE TO THERE SIZE!!! They are OS3 which is a 70 lb rate.

Muffler

Well-made reproduction of original tapered muffler.



A5230	28-31	Price Ea.	\$ 155.00
-------	-------	-----------	-----------

1928 Painted Steel Muffler

These reproduction mufflers have a distinctly different Inlet Pipe. Used beginning of production until **March 1929**.



A5230AR	28 - March 1929	Price Ea.	\$ 225.00
---------	-----------------	-----------	-----------

1928-March 1929 April 1929 to end of production

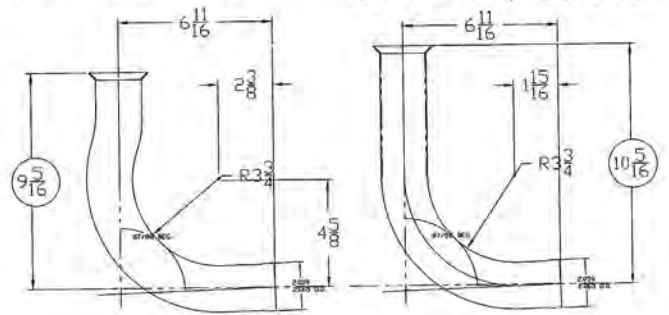

1928 Inlet Pipe on left, April 1929 to end of production on right. Note the 1928 is "one" inch shorter and has the forward curve of the pipe moved 7/16" forward to clear the motor mount.

Independent testing with a dynamo test machine (Volume 5, Number 1 of *Secrets of Speed*, July 1995) show the original design muffler increased power by 3.8 horsepower, or a 7.8 % increase over the inexpensive muffler. This is because the inexpensive muffler A5230 does not use the correct diameter pipe or the correct internal baffles; therefore, flow of the exhaust gases from the muffler is restricted, which will effect horsepower.

The Original Muffler

This is an excellent copy of the original muffler using the seven factory blue prints to duplicate the muffler Ford made. Internal pipe has 172 1/4" porting holes and 3 baffles. Exhaust passes from the internal pipe to the large muffler area in three sections which eliminates engine back pressure which affects engine performance. This correct baffling system creates that original muffler sound. The flange at the neck is correct for a perfect fit to the manifold. Best of all, 100% of the muffler is made from Stainless Steel. Years after use, you can slide under your car and the muffler system will still look and sound like new, and no rust will fall into your eyes. The steel muffler is the same as the 100% stainless muffler except out of cold roll Steel for judging purposes. Original sound and perfect fit to manifold.

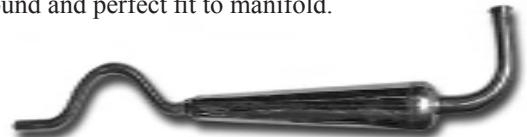

A5230S	28-31 Stainless	Price Ea.	\$ 275.00
--------	-----------------	-----------	-----------



A5230C	28-31 Steel	Price Ea.	\$ 195.00
--------	-------------	-----------	-----------

Mike's "A" FORD-ABLE Parts

MUFFLER

Hi Performance Muffler

The Hi-performance mufflers have been manufactured to look exactly like the original muffler with the mandrel bends, for engines over 80 HP. The baffles have been opened for a reduced back pressure, creating a slightly louder sound than the stock muffler. Tested to 140 HP.



A5230HP	28-31 Steel	Price Ea.	\$ 250.00
A5230HPSS	28-31 Stainless	Price Ea.	\$ 335.00

For the Tail Pipe Extensions for Station Wagon & Panel Delivery Vehicles see Page P/UP 21.

Heat Resistant Spray Paint

Resists heat up to 1500 deg. for manifold and mufflers. Spray on clean metal, no primer needed. Spray only enough to cover metal, do not over paint. 11 Oz. can.



A5240	Black	Price Ea.	\$ 9.95
A5241	Cast Iron Gray	Price Ea.	\$ 9.95

Exhaust Sleeve

Use with exhaust seal (A5251ES) to eliminate leaks between the muffler and the manifold.



A5234	28-31	Price Ea.	\$ 4.10
A5253	Muffler Cement	Price Ea.	\$ 3.25

Note:

If you are having a problem with the muffler flange being out of alignment - stick a pipe down the neck of the muffler and change the 90 Degree Angle.

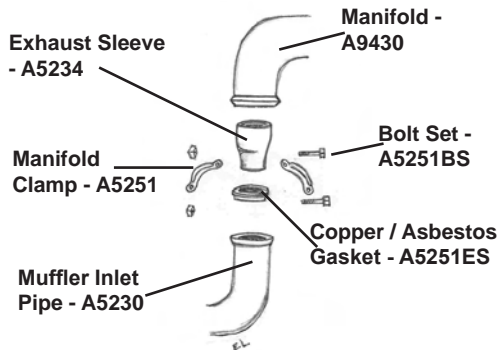

Muffler Clamp

Connects the muffler to the manifold. Cadmium bolts with brass nuts included. Made from a new steel - extremely tough, ductile and durable. Suggested by a Judging Committee. These will bend, where the cast type will break if given too much pressure - Original letters and number side to face down when installing. Includes A5251BS Bolt Set.



A5251	28-31	Price Set	\$ 7.45
-------	-------	-----------	---------

Muffler Clamp Bolt Set

If you've stripped your clamp bolts, replace with this set.



Cadmium bolts, brass nuts.

2 x 3/8 - 16 x 1 15/16 Original 3/8" Tall Brass Nuts.

A5251BS	28-31	Price Set/4	\$ 1.75
---------	-------	-------------	---------

Muffler Clamp Exhaust Seal

This special copper flanged gasket fits between the exhaust pipe and the manifold to reduce leaks.



See also A5234 - Page 96.

A5251ES	28-31	Price Ea.	\$ 3.60
---------	-------	-----------	---------

Muffler Gasket

This gasket was not a standard Ford part but will help seal exhaust leaks.

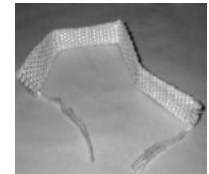

A5251MG	28-31	Price Ea.	\$ 1.45
---------	-------	-----------	---------

Muffler Tail Pipe Clamp

This clamp connects the tail pipe to the frame. Place both strips of metal on the top of the bottom frame rail.



A5256	28-31	Price Set	\$ 2.95
-------	-------	-----------	---------

Authentic Muffler Tail Pipe Clamps

Exact reproduction of Ford original including thick headed bolt. Place both strips of metal on the top of the bottom frame rail.



A5256A	'28- March '29	Price Set	\$ 7.95
--------	----------------	-----------	---------



A5256B	March '29 - end	Price Set	\$ 6.15
--------	-----------------	-----------	---------

Mike's "A" FORD-ABLE Parts

Muffler Tail Pipe Clamp Bolt Set

Original type thick headed bolt with castle nut. A Cotter pin is included A5256A but not with A5256B.



3/8 - 24 x 1 7/32 Bolt

A5257MB

March 1929 - 1931

Price Set/3 \$ 2.45

MUFFLER

Don't forget Grandfathers Day!!



See the back of the catalog with the order forms for your personal invitation. We do not allow Vendors - this is purely a time to bring out your Model A, come and have some good 'ol Southern BBQ and meet and greet all of our fellow Model A Lovers.

Order online at www.mikes-afordable.com and get a 5% discount!!

Gen.97

FRONT & REAR SPRING

Specifications:

Material:	Chromium steel alloy
Front spring leaf width:	1-3/4"
Front spring free length:	30-13/16" to 30-15/16"
Rear spring leaf width:	2-1/4"
Rear spring free length	Tudor, Fordor - 38-7/8 to 39"; Phaeton, Roadster, Coupes - 39 7/8 to 39 1/2"

Rear Traveling Spring Spreader

This compact spreader is for the rear leaf spring. Set one end against the rolled end of the spring and the other on the opposite housing bolt, and start spreading.



T5300 **28-31** **Price Ea. \$ 34.50**

Front Spring Spreader

Safely spread the front leaf spring to remove the spring or to replace the shackles.



T5301 **28-31** **Price Ea. \$ 58.95**

Front Spring Spreader

No Model A Shop should be without this tool. There is no front spring spreader on the market today to compare with this one.



T5301MOD **Price Ea. \$ 96.00**

Rear Spring Spreader

This heavy duty spring spreader, has long legs, end pads are notched to fit the rolled end of the spring. No slipping, comes with 1 1/2" Wrench for turning nuts.



T5302 **28-31** **Price Ea. \$ 98.75**

Rear Spring Spreader

No Model A Shop should be without this tool. This is a 1 piece design - no legs to fit - adjusting rod supplied. There is no rear spring spreader on the market today to compare with this one.



T5302MOD **Price Ea. \$ 129.00**

Front Spring

A good reproduction of the 10 leaf front spring with beveled ends, Clamps A5330 sold separately.



A5310A **28-31** **Now USA Made**
Price Ea. \$ 110.00

Spring Covers (Front & Rear)

Oiled strips of felt smooth your ride by oiling springs and keeping dirt out. Set includes a pair for front and rear springs.



A5310CO **28-31** **Price Set/4 \$ 34.35**

Reversed Eye Front Spring

This is a good reproduction of a 10 leaf front spring with reversed eyes. Used on Street Rods Only.



A5310RE **Price Ea. \$ 140.00**

Rear Leaf Spring

A good reproduction of original. **Clamps are NOT included.** See Page 100.

Note: 7 Leaf Springs are not always available.



A5560A **10 Leaf** **28-31** **Tudors, Fordor,**
Open and Closed Cab Pickups
Price Ea. \$ 225.00

A5560B **8 Leaf** **28-31** **Coupe, Sport Coupe & Phaeton**
29-31 **Cabriolet 68 A & B**
30-31 **Victoria**
Price Ea. \$ 215.00

A5560C **7 Leaf** **28-31** **Roadsters**
Price Ea. \$ 205.00

Center Spring Bolts

Square headed bolt with nut. Cut after assembly and peen the end of the bolt over the nut



A5345F **28-31** **Front** **5 1/2" x 5/16"**
Price Ea. \$ 1.65

A5345R **28-31** **Rear** **6 3/4" x 3/8"**
Price Ea. \$ 1.95

FRONT & REAR SPRING

Mike's "A" FORD-ABLE Parts

Shackle Bushing Reamer

Adjustable Reamer. An inexpensive import that will get the job done. See **Page 49** for Mike's Tips.



T5303TR Price Ea. \$ 24.95

Shackle Bushing Reamer

Hand Reamer for the rear and front shackle bushings. See Mike's tips on **Page 49**.



T5303R Price Ea. \$ 72.00

Shackle Bushing Drill

Drill your shackle bushings to the proper bore. An alternative to an expensive reamer.
1/2" Shank. 14.5 mm.



T5303D 09-31 Price Ea. \$ 15.10

Spring Shackle Nut Set

Set of 4 x 7/16-20 threaded castle nuts for your shackles. You will need one set for Front and one set for rear.



A5300N 28-31 Price Set/4 \$ 3.10

Spring Shackles (Imports)

Complete set of shackles with castle nuts, shackle bar, bushings and cotter pins. Not USA Made. -- But good.

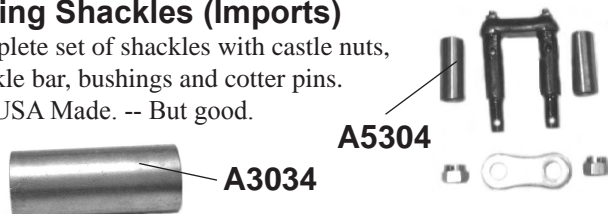

A3034	Front Bushing Only	Price Ea.	\$ 0.45
A5304	28-31 Front	Price Set/16	\$ 16.95
A5630	28-31 Rear	Price Set/16	\$ 16.95
A4020	Rear Bushings Only	Price Ea.	\$ 0.95

Sprint Shackles (USA)

Complete set with original style steel bushings. The only USA set. Comes with modern grease fittings.



A3034	Front Bushings Only	Price Ea.	\$ 0.45
A5465RE	28-31 Front	Price Set/16	\$ 27.50
A5715RE	28-31 Rear	Price Set/16	\$ 27.95
A4020	Rear Bushings Only	Price Ea.	\$ 0.95

Spring Shackle Bar

This is the original style shackle bar with corners diagonally cut. Fits front and rear. Need 4 per car.



A5468 28-31 Price Ea. \$ 2.50

Front Spring Clamps

Clamps with cadmium plated bolts and nuts. Ford script. You may have to drill a larger hole for bolt to fit.



A5330 28-32 Price Pair \$ 3.55

Front Spring Clip Bolts

Set of 2 hex bolts with square nuts for the front spring clip.

2 x 1/4" - 20 x 2 3/8 bolts.

Nut should be on the front side of clamp.



A5330MB 28-31 Price Set/4 \$ 1.25

Front Spring Clip Rivet

Spring clips were riveted to the springs on '31 Fords.



A5332 1931 Price Ea. \$ 1.50

Front Spring U Bolt

Round type used after Feb '30.

Nuts not included.



A5455B 30-31 Need 2 Price Each \$ 3.50

Front Spring U Bolt Nuts

4 piece set of castle nuts for front spring U bolts. Original type 1/2-20.



A5455N 28-34 Price Set/4 \$ 3.95

FRONT & REAR SPRING

Mike's "A" FORD-ABLE Parts

Crank Guide

This guide was used after Feb '30.
Used with round U bolt (A5455B)

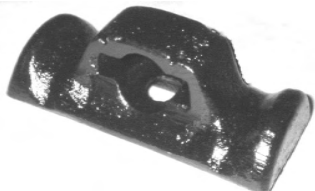

A5461B Feb '30 - '31

Price Ea. \$ 13.25

Crank Guide and U-Bolts

Square type used until Feb '30.
Nuts not included -
Order A5455N.



A5455A 28 - Feb '30 U-bolt

Price Ea. \$ 8.75

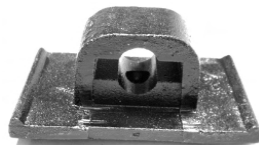

A5461A 28 - Feb '30 Guide

Price Ea. \$ 10.50

Front Spring Clip Bar

This plate holds the front spring
to the cross member.



A5458 28-31

Price Ea. \$ 8.80

Rear Spring U Bolts

Square U-bolt for rear springs on all
Model A's. Nuts sold separately.
Cut and drill depending on the number of
leaves on your spring.
These were made longer to fit a number of
models.



A5705 28-32

Price Ea. \$ 8.35

Rear Spring U-Bolt Nuts

Set of 4 castle nuts for rear spring
U-Bolts.

4 x 9/16 - 18 Castle Nuts.

Use # 37 or #37SS Cotter Pins -
See Page Gen. 34.



A5706 28-48

Price Set/4 \$ 3.95

Rear Spring Clip Bars

Holds rear spring to cross member.
2 needed.

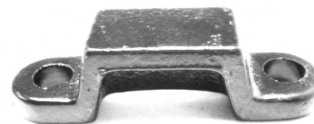

1 1/8" overall height - 7 or 8 leaf
A5708A 28-31

Price Ea. \$ 7.45

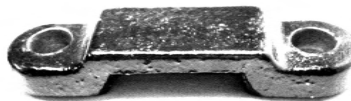

5/8" overall height - 10 or 12 leaf
A5708B 28-31

Price Ea. \$ 7.10

Rear Spring Clips

Clamps with cadmium plated
bolts and nuts. Ford Script.
Drill Larger holes to allow the
bolts or rivets to pass through.



A5724A 28-34

Price Pair \$ 5.45

Rear Spring Clip Bolts

Set of 2 hex bolts with square nuts for the rear spring clip. The
nut goes on the front side of the clamp. Used until Feb. '31 then
replaced by Rivets A5332 - See Page Gen. 99.



A5724MB 28-31 2 x 1/4-20 x 2 7/8" Bolts
and Hex Nuts

Price Set \$ 1.50

Rear Spring - Floorpan Anti-Squeak

This 15" piece of 1/8" x 2" welt fits on
the rear floorpan with split rivets - this
keeps the pan from rubbing the top of the
crossmember. Use rivets A16745 -
See the Hood Section in the car
specific Sections.



A5701 28-31

Price Ea. \$ 1.50

Cotter Pin Set

This is an entire set of Cotter Pins
if you're refurbishing the whole car.



#37 28-31

Price Set/168 \$ 5.25

Stainless Steel Cotter Pin Set

This is an entire set of stainless steel
cotter pins if you're refurbishing the
whole car.



#37SS 28-31

Price Set/156 \$ 13.50

FRONT & REAR SPRING

Engines

Mike's now proudly offers 6 Different Engine Options.

Extra Long Block Engine # 1 with original Model A Head

This is a Stock Engine with an original Model A Head

A6001 28-31 Price Ea. \$ 3,150.00

Extra Long Block Engine # 2 with High Compression Head

This is a high performance engine with a Police Head A6010PH.

A6002 28-31 Price Ea. \$ 3,350.00

Inserted Extra Long Block Engine # 3

This is a high performance engine with a Police Head (A6010PH) and new Modern Inserted Rods.

A6003 28-31 Price Ea. \$ 3,850.00

Balanced Extra Long Block Engine # 4

This is a high performance engine with a Police Head (A6010PH) and Balanced Counterweight Cranks.

A6004 28-31 Price Ea. \$ 3,950.00

Touring Extra Long Block Engine # 5

This is a high Performance engine with a Police Head (A6010PH), new Modern Inserted Rods and Balanced Counterweight Crank.

A6005 28-31 Price Ea. \$4,225.00

Touring Extra Long Block Engine # 6

This is the same as Engine # 5 but has the New Crank A6300.

A6006 28-31 Price Ea. \$4875.00

If you do not require the bellhousing and Pedals you can deduct \$200.00 from any of the choices above.

All of our engines are bench run for approx. 2 hrs. **A core charge of \$500.00 will apply to all engines, and added to your charge.** Once we have received your core, and had it thoroughly inspected we will notify you if a full credit is due. See Notes under "Cores" Below. **A crating charge of \$100.00 will be added.**

Shipping

We will arrange the shipping and handling of your engine to you with a freight line company. **The return of the Core is at the customers expense.** Please ensure that there are adequate unloading facilities at your drop off point.

Cores

Please drain all fluids from your core before shipping. Please return your core in the crating that your new engine will arrive in. Upon arrival, your core will be thoroughly inspected. It is at this stage that you will be advised if you have returned an acceptable core. Engines with broken blocks, crankshafts, cracks and welds are not considered Re-buildable, nor will we accept engines that are rusted! We reserve the right at this time to advise you if there will be a charge for the unusable part or parts thereof.

Warranty Information

Give Mike's a call to have our Warranty Form mailed to you. **This form has to be signed and returned to Mike's before an Engine will be shipped.**

Note

We are not new at this business. We started selling complete engines due to customer requests. We are very proud of our engines and of their performance. We invite your questions and suggestions as it is our endeavor to produce the very best engines available, with the minimum of on site assembly and adjustments.

Our Rebuilt Engines consist of the following:

1. Engine vatted, cleaned and painted.
2. Block & head resurfaced.
3. Crankshaft re-ground & balanced.
4. New Modern Front Oil Seal installed.
5. Cylinders bored.
6. New pistons & Rings.
7. New Valve Guides, Springs & Keepers.
8. Stainless Steel Valves.
9. Double Lock Adjustable Lifters.
10. New Timing Gears.
11. Rebabbitted Rods.
12. Wrist Pin Bushings.
13. Rebabbitted Main Bearings.
14. Line Bored.
15. All External Bolts are new.
16. New Head Nut & Bolt Set.
17. Rebuilt Oil Pump.
18. Reconditioned Oil Pan.
19. New Crank Pulley and Nut.
20. Valve Cover & Oil Return Pipe.
21. Rebuilt & Balanced Pressure Plate & Clutch
22. Refurbished Clutch Housing
23. Refurbished Bell Housing.
24. Refurbished Clutch & Brake Pedals.
25. Throw Out Bearing Hub and Spring.
26. New Manifold Studs Installed.
27. New Waterpump Studs Installed.
28. Radius Ball Felt, Pin & Bolts Installed.
29. New Engine Flywheel Cover Installed.

**OVER 600
ENGINES
SOLD SINCE
1994.**

ENGINES

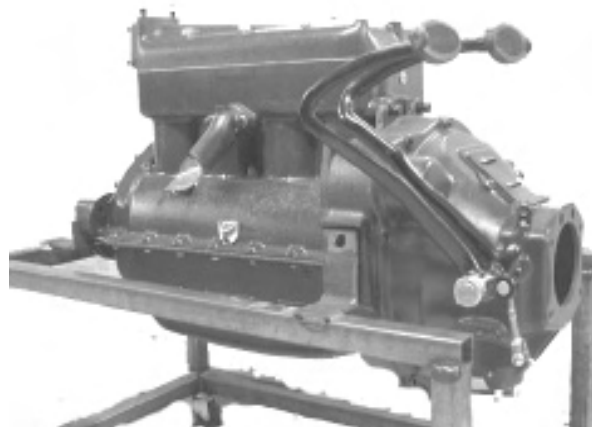

Motor Parts

Specifications:

HEAD:

1928 Head: 4.3 to 1 compression ratio, 47.3 HP, 242cc displacement. Compression in individual cylinders: 80, 85, 83, 82 PSI

1930 Head: 4.1 to 1 compression ratio, 44.3 HP, 258cc displacement. Compression in individual cylinders: 77,79,82,79 PSI

Normal listed compression: A6050A, 75 lbs; A6050B, 110 lbs; B6050, 90 lbs

Head nut torque: 55 ft/lbs

CYLINDER BLOCK:

Length: 19-5/16"
 Width: 7-13/16"
 Height: 11-1/2"
 Bore: 3.875" to 3.876"
 Bottom of block to camshaft bore center line: 2.876" to 2.878"
 Top of block to camshaft bore center line: 8.624" to 8.627"
 Valve lifter and guide bore: .594" to .5945" diameter
 Distributor drive gear bore: .9365" to .9375" diameter
 Cylinder outside diameter: 4-3/8" (wall thickness 1/4")
 Flatness top of block: .003" to .005"
 Cylinder bore perpendicular to top of block: .001" to .002"

ENGINE:

Rated horsepower: 24.03 SAE
 Brake horsepower: 40 HP at 2200rpm (Model AF 28 at 2000 rpm)

Firing order: 1-2-4-3
 Compression ratio: 4.22 to 1
 Compression pressure: A6050A head, 76 PSI;
 A6050B head, 110 PSI
 B6050 head, 90 PSI

Piston displacement: 200.5 cu. Inches
 Bore: 3.876" (Model AF: 3.050")
 Stroke: 4.250"
 Torque: 128 ft/lbs at 1000 rpm

Cylinder offset from crankshaft center line: 1/8"
 Crankshaft to camshaft center line: 4.155"

***** MIKE'S TIPS *****

Removing a stuck or tight head from the block - firstly loosen all 14 head studs to about 1/8" above the head. Then start the engine and approx. on the second revolution the compression should have forced the head up. STOP at this stage as compression will have been lost.

DO YOU NEED AN ENGINE?? See Page 101 for a range of engines. Warranty paperwork must be signed and returned before an engine will be shipped. Call for your paperwork today!!

Engine Bolt Kit

This set has all the exposed nuts, bolts, and washers needed for assembling your new or refurbished engine. Kit does NOT include A6017MB & A6019MB.

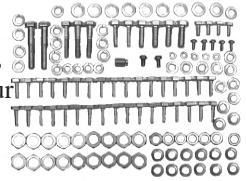

#35 28-31 Price Set/140 \$ 11.95

Gasket Set

Complete engine gasket kit for your Model A. When ordering a complete engine gasket set - order the A6008CLH and then you have a choice of head gaskets below.

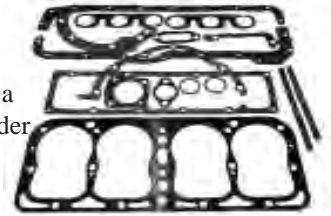

A6008CLH Less Head Gasket Price Set \$ 14.50
 B6008 Model "B" Gasket Set Price Set/17 \$ 52.80

Copper Head Gasket - Felpro

A superior quality gasket to the standard copper gasket. Use Gasket Sealant A6052S - See Page Gen. 103.
 A6051A 28-31 Price Ea. \$ 22.25

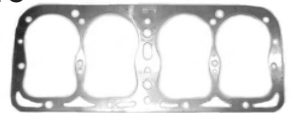

Premium "A" Head Gasket

This gasket is by far the best gasket on the market today. It has a solid steel core, sandwiched by heavy-duty density material coated with silicone. It has additional high temperature silicone bonds surrounding all the water passages. No need for any sealants for installation, torque this down correctly and you will have no more water leaking from the head nut studs. Use the B6051M for High compression or Police Heads.



A6051M 28-31 Price Ea. \$ 28.75

Premium 'B' Head Gasket

Same as the A6051M gasket above. Though made for '32-'34 Fords, this gasket is recommended when using the A6010PH High Compression head. **This gasket will NOT work on Brumfield heads.**

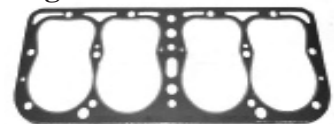

B6051M 32-34 Price Ea. \$ 24.95

MOTOR PARTS

Mike's "A" FORD-ABLE Parts

Head Gasket Sealant

Mike recommends this Sealant. Always helpful, usually needed. Spray both sides of your head gasket and it will fill in minor imperfections in your head or block. Not for use with **A6051M OR B6051M** Premium Head gaskets.



A6052S **09-31** **Price Ea.** \$ **9.50**

See more Sealants & Engine Paints under the Restoration Supplies Section on Page Gen. 29.

High Compression Police Head

Cast Iron - looks exactly like the original head - gives **5.5:1** Comp. Use the **B6051M** Gasket.



A6010PH **28-31** **Price Ea.** \$ **275.00**

Cylinder Head Puller and Engine Lifter

This new tool can be used to pull the engine, or just for lifting the head. The puller comes with special hardware.



T6010P **28-31** **Price Set** \$ **69.95**

Engine Lift

Used to lift engines and stock cylinder heads. 2 Makes the job a little easier.



T17022 **28-31** **Price Set** \$ **10.25**

Stud Installation and Removal Tool

Use this tool for installing or removing studs on your cylinder head.



T6065 **28-31** **Price Ea.** \$ **39.95**

Stud Thread Repair Kit

Sooner or later we all have to repair threads in our block. This Heli-Coil kit has everything you need except the drill bit. (Use a 29/64" tap drill bit). 6 Springs.



T6065RK **28-34** **Price Set/8** \$ **26.25**

Head Studs

Regular short studs are 3 1/2" long; long outlet studs are 5 3/4". Grade 5 hardened with dome heads as original.



A6066 **28-31** **Regular Short Studs**
Price Ea. \$ **0.75**

A6067 **28-31** **Long Water Outlet Studs**
Price Ea. \$ **2.75**

Oversize Thread 3 1/2" Long STD Head Bolt

The engine block half of this 3 1/2" stud is oversized to 1/2 -13 thread for blocks with stripped threads. You must drill the block with a 27/64" drill bit and tap. This is a stronger grade 8 Stud.



A6067B **28-31** **Price Ea.** \$ **7.85**

Head Nuts

A complete set of 14 cadmium plated 7/16" - 20 thick head nuts. Has washer surface on bottom as original.



Torque 50/55 ft lbs. while hot.

A6064S **28-34** **Price Set/14** \$ **3.65**

Head Nut Torque Tool

You no longer have to remove the distributor!! Use this new tool to torque the nut that hides behind the distributor body.



T6064T **28-31** **Price Ea.** \$ **22.95**

Head Stud and Nut Set

A complete set of head studs and nuts. Includes water outlet and ignition clamp studs. Grade 5 Hardened with dome heads as original.

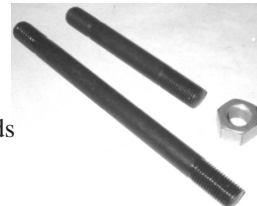

A6064-66 **28-31** **Price Set/28** \$ **15.95**

Made of Chrome Moly Steel - Guaranteed not to stretch - For High Compression Heads. Also has high strength nuts included.

A6064/66HD **28-31** **Price Set/28** \$ **61.00**

MIKE'S TIPS

Always make sure that before you start your engine the spark lever is in the up (retard) position. Otherwise the explosion will drive the piston backwards down the cylinder. This will damage the Starter, Starter Drive, Fly Wheel, Ring Gear and the Fiber Cam Gear. If you intend to hand crank the engine, you could quite easily break your arm or wrist.

Mike's "A" FORD-ABLE Parts

Head Bolt Tightening Sequence

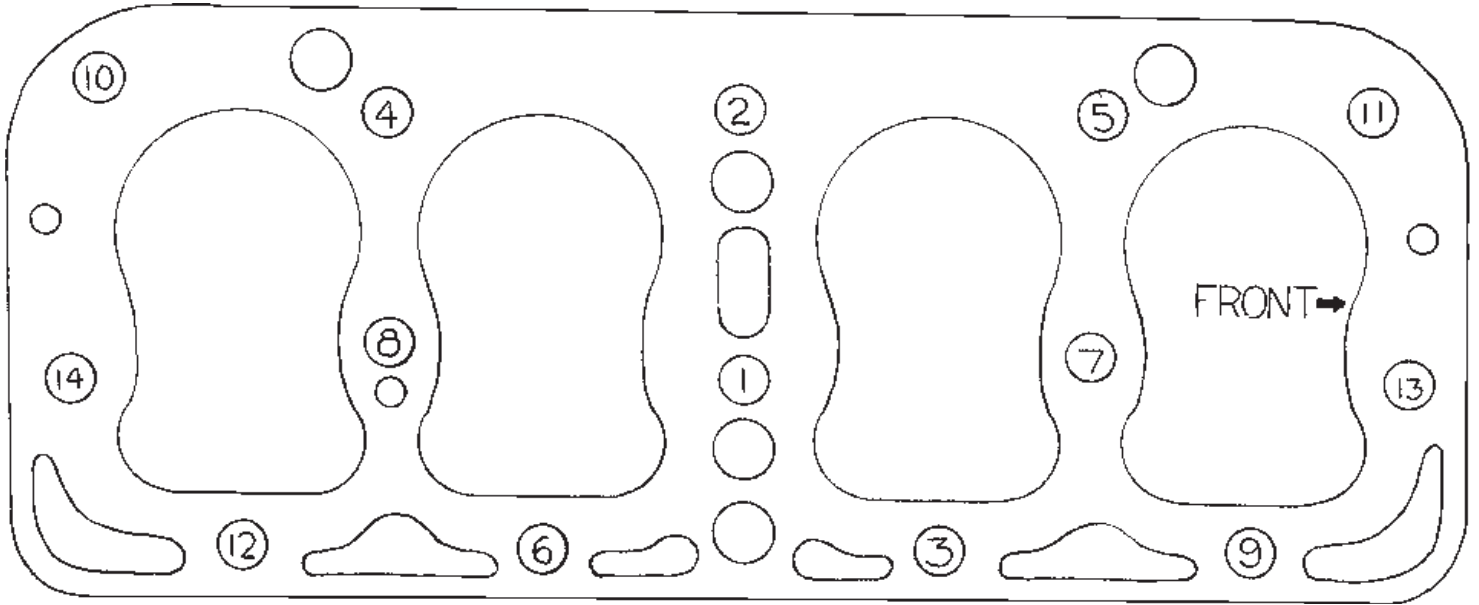

Torque in 3 steps - 35 - 45 - 50/55 foot lbs.
When engine is hot - Re Torque after 100 Miles
Seam around cylinder holes face down.

Front Motor Mount

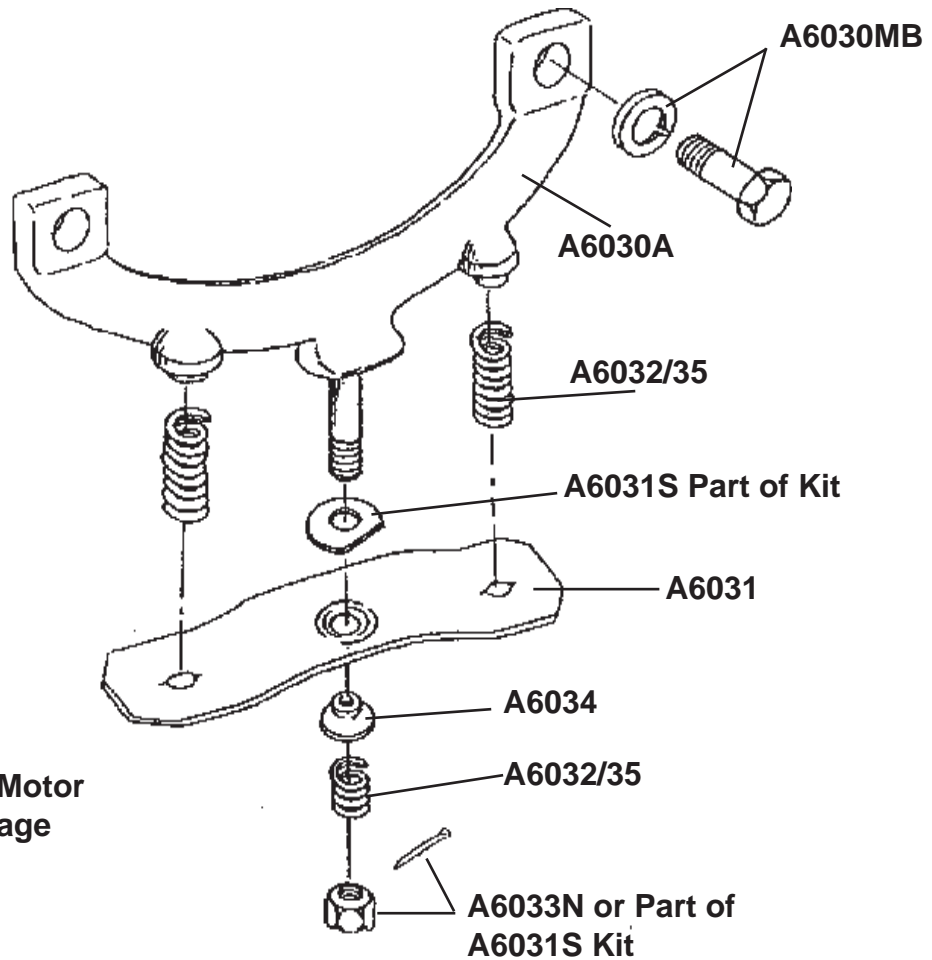

See New Design - Front Motor
Mount (A6031FAM) on Page
Gen. 106.

MOTOR PARTS

Mike's "A" FORD-ABLE Parts

Ignition Clamp Studs

These studs are slightly longer for the ignition cable clamp.

This is the #8 stud on the head.



A6066A 4 1/2" Long

Ignition Stud

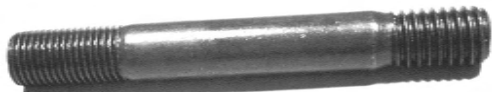

A6066B 4 1/8" Long

Ignition Stud



A6066C 3 3/4" Long

A6066A	Jan-April '28	Price Ea.	\$ 2.25
A6066B	Apr. '28-Mar. '29	Price Ea.	\$ 2.25
A6066C	Mar. '29-end	Price Ea.	\$ 1.75

Timing Gear Side Cover Bolts

2 special black oxide dome-headed bolts
1 short, 1 long - to bolt the side cover
over the timing gear. Lock washers
were only used 1928 - mid 1930.



A6017MB	28-31	1-7/16" - 14 x 2 3/16"	
		1-7/16" - 14 x 1 3/8"	
		Price Set/2	\$ 3.20

Timing Gear / Side Cover Gasket

Paper type gasket for the side timing gear cover.

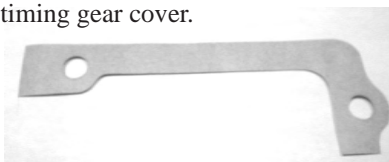

A6018	28-31	Price Ea.	\$ 0.75
-------	-------	-----------	---------

Timing Gear Cover Gasket

Paper type gasket for the front timing cover.



A6020	28-31	Price Ea.	\$ 1.35
-------	-------	-----------	---------

Automatic Timing Pin Setter

Shown with a timing Pin (not Included).
This is an amazing little tool.
See Page Gen. 110 for more
Timing Tools.



T6254	28-31	Price Set	\$ 9.50
-------	-------	-----------	---------

Timing Cover Bolts

Original style black oxide dome-headed
bolts to attach the front timing cover.
6 Bolts go across the front - the seventh
is recessed into the corner with lug washer
Torque to 25 Ft. Lbs.



A6019MB	28-31	Set of 7- 3/8" - 16 x 1 1/8" bolts	
		Price Set/14	\$ 3.35

Timing Pin

Jan. 1929 till end used a pin with a
square base.



A6023	29-31	Price Ea.	\$ 3.25
-------	-------	-----------	---------

Timing Pin

The early 1928 Timing Pin with Hex Base.
Order the A6028 Washer.

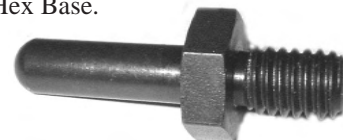

A6023AR	1928	Price Ea.	\$ 3.25
---------	------	-----------	---------

Timing Pin Washer

If you show a '28 A, you'll need this thin
copper washer.



A6028	1928	Price Ea.	\$ 0.45
-------	------	-----------	---------

Motor Mount Yoke

This is a cast iron front motor
mount yoke to connect the engine
to front cross member.



A6030A	28-31	Price Ea.	\$ 31.75
--------	-------	-----------	----------

Front Motor Mount Bolts

Set of bolts and lock washers needed
to attach the yoke to the engine.



A6030MB	28-31	2 x 1/2" - 13 x 1 1/16 bolt & l.w.	
		Price Set/4	\$ 1.65

MOTOR PARTS

Mike's "A" FORD-ABLE Parts

Front Float-A-Motor Kit

If you need a smoother running engine with less vibration, this is just what you need. It mounts to the crossmember on two rubber mounts. Two holes are needed to be drilled on the crossmember - ideal if front crossmember

center hole is worn out. It saves you from replacing the crossmember. See Page Gen. 89 for Rear Float-A-Motor Kit.

A6031FAM 28-31 Price Set/11 \$ 65.00

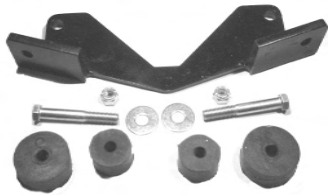

Front Motor Mount Spring (Included in A6031S)

This auxiliary spring is frequently missing. It holds the 2 small coil springs in place on the front motor mount.

A6031 28-31 Price Ea. \$ 3.10



Front Motor Mount Set

This 7 piece set includes the auxiliary spring, 3 coil springs, washer, castle nut, and cotter pin. Make sure that you have A6034 bushing.

A6031S 28-31 Price Set/7 \$ 6.50

A6032-35 28-31 Springs only - 2 Long - 1 Short Price Set/3 \$ 1.80



Front Engine Support Bushing

The brass bushing fits into the cross member from the underside as part of the motor mount support.

A6034 28-31 Price Ea. \$ 1.50



Front Engine Mount Nut

Castle nut to attach the yoke to the cross member. Purchase #37 or #37SS Cotter Pins - See Page Gen. 34. 7/16" - 20.

A6033N 28-31 Price Ea. \$ 0.60



PISTONS

Specifications:

Displacement:	200.5 cu. Inches
Material:	Aluminum
Weight:	1 lb. 1-7/8 oz. (476.8 grams)
Variance in weight of pistons:	+ or - 2 grams
Weight with rings installed:	1 lb. 4-1/2 oz. (581.2 grams)
Weight with rings and pin:	1 lb. 8-3/4 oz. (701.7 grams)
Diameter:	3.8745" (Bore 3.875")
Length:	3-29/32"
Piston skirt:	.001:smaller at the top than the bottom of the skirt
Piston pin hole:	.9996" to .9998" diameter
Piston pin diameter:	1.0001" to 1.0004"
Pin length:	3.536" to 3.546"
Compression height (top of piston to pin circumference):	1-29/32"
Variation in piston compression height:	.003" to .005"
Piston pin bushing:	I.D. .992", O.D. 1.0675"
Length:	1.593"
Pin fit in rod bushing:	.0003" max
Pin fit in piston:	.0002" to .0005 shrink fit
Pin bore parallel to head of piston:	+ or - .001"
Piston fit in cylinder:	.002" max

Pistons (Weight Matched)

Set of 4 aluminum 3-ring pistons. End lock piston pins included. Sorry, Sold in sets of 4 Only.

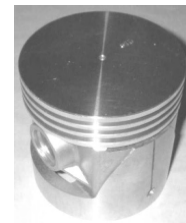

A6108-STD	28-34	fits 28-34 4 cylinder	Price Set	\$ 95.00
A6108-020	28-34	.020 oversize	Price Set	\$ 95.00
A6108-030	28-34	.030 oversize	Price Set	\$ 95.00
A6108-040	28-34	.040 oversize	Price Set	\$ 95.00
A6108-060	28-34	.060 oversize	Price Set	\$ 95.00
A6108-080	28-34	.080 oversize	Price Set	\$ 95.00
A6108-100	28-34	.100 oversize	Price Set	\$ 95.00
A6108-125	28-34	.125 oversize	Price Set	\$ 95.00

Mike's "A" FORD-ABLE Parts

Piston Pin Sets

Set of 4 endlock style piston pins. These pins are included with new pistons.



A6135-STD **28-34** **standard size**
Price Set/4 \$ 24.95

Piston Pin Retainers

Use this little clip to keep the piston pin from coming out of the piston. For the end lock style pistons. 2 Required per piston. Comes with complete Piston Sets.



A6140 **28-31** **Price Ea.** \$ 0.40

Cylinder Sleeves

If you've bored your cylinders as far as you can, take them back to standard bore with this sleeve.



A6055 **28-34** **Std is 3.875 - 3/32" thick**
Price Ea. \$ 36.00

Order Online Now and Save 5%

Visit our website for all your Model "A" needs.



www.mikes-afordable.com

PISTON RINGS

PISTON RINGS

Specifications:

Ring diameter: same as piston, 3.875" stock
 Ring groove: depth, 7/32";
 width-upper 2, 1/8"-lower, 5/32"
 Ring taper: .001" narrower at top than the
 bottom
 Ring clearance in groove: .001" to .002"
 Ring end gap: top-.012" to .015"; middle-.010"
 to .012"; lower-.008" to .010"

Piston Rings

Complete set of rings for 3-ring pistons. The gap of the rings must NOT line up, keep them approx. 1/4 turn from each other.

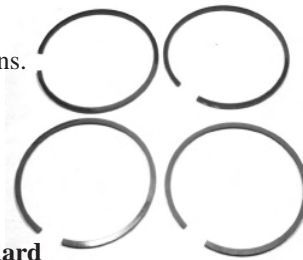

A6149-STD	28-34	Standard	Price Set/16	\$ 28.95
A6149-020	28-34	.020 oversize	Price Set/16	\$ 28.95
A6149-030	28-34	.030 oversize	Price Set /16	\$ 28.95
A6149-040	28-34	.040 oversize	Price Set /16	\$ 28.95
A6149-060	28-34	.060 oversize	Price Set/16	\$ 28.95
A6149-080	28-34	.080 oversize	Price Set/16	\$ 28.95
A6149-100	28-34	.100 oversize	Price Set/16	\$ 28.95
A6149-125	28-34	.125 oversize	Price Set/16	\$ 28.95

Piston Ring Compressor Tool

If you do your own work, you need one of these to make installation of rings a breeze.



T6149T **any year**
Price Ea. \$ 9.75

Plastigage

Use this thin waxed string to help check the clearance on the connecting rods and main bearings. Bearing clearance for both rods and mains is .0015.



PG1	Range .001 - .003	Price Ea.	\$ 3.00
PG2	Range .002 - .006	Price Ea.	\$ 3.00

CONNECTING RODS

Specifications:

Material:	Steel forging
Weight:	1lb. 6 oz.
Balance Weight:	552 grams +or- 1 gram, crank end 198 grams +or- 1 gram, pin end
Length:	7-1/2" center to center
Crankshaft bearing:	1-1/2" diameter, 1-5/8" wide
Piston pin bearing:	1" diameter, 1-5/8" wide
Bearing side clearance:	.008" to .012"
Pin side clearance:	.040" to .053" between pin bosses
Piston pin clearance:	.0005"
Crankshaft clearance:	.001"
Bearing cap bolt torque:	40-50 ft. lbs.
(Connecting rod assembled with oil dippers toward camshaft)	

Connecting Rods

Original rebabbitted rods made with wrist pin bushings installed.

EXCHANGE ONLY. Sorry, sold in sets of 4 only. The open side of the dipper on the rod faces the valve chamber.

A6200C	Refundable Core Charge - Ea	\$ 10.00
A6200-STD	28-31 Standard -	1.500
A6200-010	28-31 .010 oversize -	1.490
A6200-020	28-31 .020 oversize -	1.480
A6200-030	28-31 .030 oversize -	1.470
A6200-040	28-31 .040 oversize -	1.460
		Price Set/4 \$ 176.00

NEW Inserted Connecting Rods

These 1541 alloy steel and stress relieved rods come complete with bearings, pin fitted, aligned and static balanced. NO Cores Required.

A6201-STD	28-31 Standard	
A6201-010	28-31 .010 Over	
A6201-020	28-31 .020 Over	
A6201-030	28-31 .030 Over	
A6201-040	28-31 .040 Over	
		Price Set/4 \$ 500.00

Connecting Rod Nuts

Castle nut to attach the connecting rod to the rod cap. 7/16" - 20.

Purchase #37 or #37SS Cotter Pins - See Page Gen. 34.

A6200N	28-31	Price Ea.	\$ 0.60
A6200NS	28-31	Price Set/8	\$ 4.70

Wrist Pin Bushings

You'll need one for each rod for each lock style piston. Must be reamed to fit wrist pin. Need 4 per engine.



A6207	28-31	Price Ea.	\$ 1.50
-------	-------	-----------	---------

Laminated Rod Shims

A set of 8 laminated shims to do all 4 rods.

Starts out at .030 but peel off layer to get correct fit - 6 layers per set - a sharp knife is needed to separate.



A6220	28-34	Price Set/8	\$ 6.25
-------	-------	-------------	---------

For our brand new Counter Balanced Cranks - See Page 109.

Do you need a Discount on your parts?

Order online at www.mikes-aford-able.com and save 5% !!

CRANKSHAFT/ CAMSHAFT

Specifications:

CRANKSHAFT:

Material:	Special Ford carbon manganese steel
Weight:	28 lbs.
Length:	26"
Diameter:	1.624" main bearings 1.499" crank pins
Length of main bearings:	Front and center, 2"; rear, 3"
Length of crank pins:	1-5/8"
Crank pin taper and roundness:	.0005" to .001"
Total main bearing surface:	11-1/2" sq. In.
Rear flange thickness:	3/8"
Crankshaft gear:	25 spiral teeth
End clearance:	.004" to .007"
Main bearing clearance:	.001"
Crankshaft straightness:	.0005" to .001"
Main bearing cap torque:	80-100 ft. lbs.
Distance from top surface of front crossmember to crankshaft center line:	2-33/64"

CAMSHAFT:

Shaft diameter:	7/8"
Bearing diameter:	1.560"
Block bore diameter:	1.561"
Bearing clearance:(max.):	.003"
Bearing length:	Front, 1-3/4"; center, 2" rear 1"; 4th (1928), 7/8"
Lift of cam:	.303" (Model B: .339" exhaust; .334" intake)
Duration:	236°
Lobe center angle:	113-1/2°
End play spring tension:	approx. 35 lbs.
Timing gear mounting flange:	2-5/16" diameter, 5/16" thick
Camshaft material:	Special Ford carbon manganese steel
Camshaft gear:	Bakelized material
No. of gear teeth:	50
Camshaft gear type:	spiral teeth
Gear backlash:	.003" to .005"
Gear rotation speed:	1/2 of crankshaft
Camshaft straightness:	.0005" to .001"
Variation of eccentricity of pitch diameter of gear teeth:	.0015"
Variation in maintaining center distance of mating gears:	+or- .001"
Gear tolerance in regular spacing of teeth:	0.0"

Timing Kit

Set your own timing with this complete kit with instructions. A timing light is needed for this kit.



T6252

28-31

Price Set/5 \$ 31.50

Reground Cams

Get your camshaft back to original specs with this swap for your re-buildable cam. The journals must be free of pits and the oil pump drive gear teeth must be acceptable. **Exchange Only. Sorry I must have your old cam before I can ship a replacement.** Original journal size is 1.560.



A6250AR 1928 5 Bearing Price Ea. \$ 75.00

A6250 28-31 3 Bearing Price Ea. \$ 75.00

New Crank

This is a brand new Model A Counter Slung Crankshaft. Made out of Non - Twist Steel. They have been designed to Ford Spec's and tested in the USA, but are made overseas. With a correctly prepared block the crankshaft can be dropped in without any modifications. The manufacturer does recommend removing 10 pounds from the O.D. of the flywheel. This would require rebalancing, but does not have to be done in order to install the crankshaft.



A6300

28-31

Price Ea. \$ 950.00

Crankshaft Counter Balanced Weights

Used when converting a Standard "A" crank to "B" counter Balanced Style. Must be machined and balanced at your engine rebuilders. These are laser cut to minimize machining.



A6450

28-31

Price Set/4 \$ 80.00

Camshaft Dowel Pins

These 2 pins hold your timing gear in position on the camshaft.



A6253

28-31

Price Pair \$ 2.50

Cam Shaft Nut Tool

Remove/install your cam nut with this special tool that won't damage the nut. Use a 1 1/8" socket with this tool. Retighten after turning engine a few revolutions.

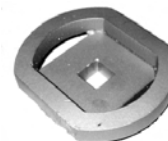

T6251

28-34

Price Ea. \$ 19.25

Mike's "A" FORD-ABLE Parts

Timing Gear

Standard and oversize fiber timing gear. The two dowel pin holes in the gear are off center. If the gear will not slide onto the dowels entirely, then rotate the gear 180 Degrees for a proper fit. A good idea would be to enlarge the timing pin holes with a 5/16" bit to make it a bit easier to locate. Check and check again, that the timing marks line up on the Crankshaft gear and the Camshaft gear. Excellent quality.

A6256LSTD

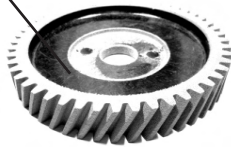

A6256003



A6256LSTD	Best Quality - Laminated Gear		
	28-34	Price Ea.	\$ 39.50
A6256STD	28-34	Price Ea.	\$ 29.95
A6256003	28-34	Price Ea.	\$ 31.95
A6256005	28-34	Price Ea.	\$ 29.95

Timing Wrench

This wrench is designed to easily rotate the crankshaft of your Model A to determine top dead center from inside the engine compartment. Comes with complete instructions.



T6253	28-31	Price Ea.	\$ 39.95
--------------	-------	-----------	----------

EZ Timing Pin Setter

Shown with timing pin (not included.) This is an amazing little tool. Once you have used it you will tell all your friends.



T6254	28-31	Price Set	\$ 9.50
--------------	-------	-----------	---------

Camshaft Nut

Replace your bent or damaged nut with this one. This has a Standard right hand thread. Torque to 100 Ft. lbs.



A6259	28-34	Price Ea.	\$ 4.25
--------------	-------	-----------	---------

Modern Camshaft Nut

Replace the original odd shaped nut with a standard Hex Nut. Use a 1 1/4" Wrench. Makes the job so much easier.



A6259M	28-34	Price Ea.	\$ 17.95
---------------	-------	-----------	----------

Camshaft Thrust Plunger

This plunger with spring fits into the front timing cover to control end play in the cam.

VERY IMPORTANT:

Be sure to grease this when you install it otherwise your engine will make a tremendous noise.



A6275/76	28-34	Price Set	\$ 3.95
-----------------	-------	-----------	---------

Crank Gear Key - #18

Holds the crankshaft gear in place on the crankshaft.

1/4 x 1 1/8 x 15/32.

A6307	28-32	Price Ea.	\$ 1.10
--------------	-------	-----------	---------



Crankshaft Gear

This quality steel crankshaft gear drives the timing gear.



A6306	28-34	Price Ea.	\$ 11.50
--------------	-------	-----------	----------

Crank

This dual purpose tool can use one end to crank your car and the other to change a tire.

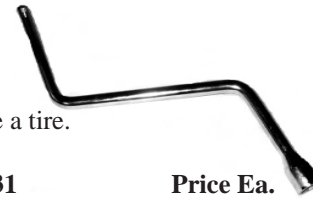

T17036	28-31	Price Ea.	\$ 11.95
---------------	-------	-----------	----------

Crankshaft Oil Slinger

Fits on the front of the crankshaft. Rolled edge faces crank pulley.



A6310	28-34	Price Ea.	\$ 2.45
--------------	-------	-----------	---------

Crankshaft Pulley

Originally one-piece pulley is what Ford used but you have to remove the radiator. If you're replacing yours, consider the 2 piece that can be removed/installed without removing the radiator. Paint Engine green for judging.



A6312A	28-34	Two piece	Price Ea. \$ 37.50
---------------	-------	-----------	--------------------

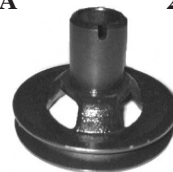

A6312B	28-31	One piece	Price Ea. \$ 23.95
---------------	-------	-----------	--------------------

Crank Ratchet Nut

This nut holds the pulley on the crankshaft and the crank end fits to turn the motor. Case hardened steel - Excellent quality. For Judging - raven finish or paint black. Torque to 80 Ft. Lbs.

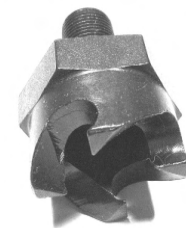

A6319A	28-31	Price Ea.	\$ 9.95
---------------	-------	-----------	---------

CRANKSHAFT/CAMSHAFT

Mike's "A" FORD-ABLE Parts

Camshaft Ratchet Nut Wrench

This handy tool lets you remove/tighten the nut without removing the radiator using a 1 3/8" Ratchet.

Timing made easy. Use a T6253 so that you can turn the crank backwards if you miss the indent.



T6320 28-31 Price Ea. \$ 39.25

Oil Drain

This screws into the rear main bearing to recirculate the oil back to the pan. Spot weld or it can vibrate loose.



A6328A 28-29 5/16" Price Ea. \$ 3.40

A6328B 30-31 3/8" Price Ea. \$ 2.25

Oil Drain Tube - 1932

This screws into the rear main bearing to recirculate the oil back to the pan. Spot Weld or it can vibrate loose. Finally available for the 1932's.



B6328R 1932 Price Ea. \$ 6.75

Rear Main Thrust

Use this to act as your thrust if your old rear main bearing has cracked. This bronze washer replaces the original A6335 Rear Main Oil Seal that went up in the block. Also used for inserted engines.



A6334 28-31 Price Ea. \$ 31.00

Rear Main Oil Seal

If you're rebuilding or overhauling your engine, be sure to get a new seal. This cast aluminum insert goes back into the block.

Ford did not use any cork or other material in the grooves to seal in the oil.



A6335 28-31 Price Ea. \$ 9.75

***** Please Note *****

When using the A6336MOD and B6336BMOD We feel we must advise you, that this is not the easiest job to do, and if not done correctly you will have destroyed a good crank. This is not one of my favorite items.

"Modern" Rear & Front Main Seal

This modern replacement really does help eliminate rear main oil leaks but only if your crankshaft is properly machined.

Instructions included.



A6336MOD 28-31 Rear Seal Price Ea. \$ 12.15
B6336BMOD 32-34 Rear Seal Price Ea. \$ 15.00



The front seal works Great!!

A6700M 28-31 Front Seal Price Ea. \$ 14.95

This replaces the 2 piece rope type seal - No machining required on front seal only.

Laminated Main Bearing Shim Set

A complete set of laminated shims; 2 for rear main, 4 for center and front main bearings. 6 Layers per shim - each layer is .002 thick.

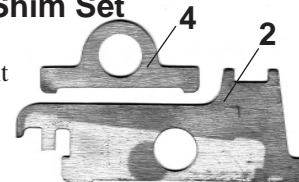

A6340/46 28-31 Price Set/6 \$ 5.20
B6340/46 32-34 Price Set/6 \$ 8.95

Main Bearing Bolt Set

Use this kit to replace those tired old main bearing bolts. This kit contains four long and two short grade 8 bolts. Six Grade 8 Hi-hex nuts, eight steel washers and eight neoprene lined seal tite washers. Instructions Included.



A6348MB 28-31 Price Set \$ 49.70

Main Bearing Bolt Castle Nut

1/2"- 20 Original style castle nut. Need six per engine. Should be painted black. Order #37 or #37SS Cotter Pins - See Page Gen. 34.

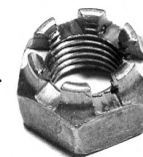

A6348 28-31 Price Ea. \$ 0.80

***** MIKE'S TIPS *****

For Removing the Front and Center Main Bearing Bolts, use a 9/16" eight point socket, 1/2" drive. Use the socket on the head of the bearing bolt to remove it.

CRANKSHAFT/CAMSHAFT

Mike's "A" FORD-ABLE Parts

FLYWHEEL

Specifications:

Weight: 63lbs., 4oz. (Model B 52 to 55 lbs)
 Balance: Within .15 in./oz.
 Ring gear shoulder diameter: 12.470"
 Ring gear outside diameter: 14.2"
 No. of ring gear teeth: 112
 Ring gear to starter drive ratio: 11.2 to 1
 Flywheel bolt torque: 65 ft lbs.
 Pilot bearing hole is concentric with crankshaft flange shoulder within .002 TIR (total indicator reading)
 Clutch mounting surface and clutch disc surface must run true to crankshaft within .005" TIR
 Clutch mounting shoulder diameter must be concentric with crankshaft flange diameter within .005" TIR

***** MIKE'S TIPS *****

The Flywheels purpose is to provide momentum to keep the crankshaft spinning. As the flywheel spins faster, a vibration will occur if it is out of balance. It is best to have your flywheel, with clutch and pressure plate balanced so that when placing in the clutch disc and reinstalling the pressure plate it will be in the same balanced position.

Reconditioned Flywheel

Ask Mike about a reconditioned flywheel. Not for multiple disc clutch. Comes with ring gear and pilot bearing. These have been surfaced and faced.



A6375 Exchange Only Price Each \$ 95.00

1932 Modified Flywheel

This flywheel has been modified for a stock transmission. It includes the flywheel, clutch disc & pressure plate. They are resurfaced and balanced to reduce vibration. The ring gear and pilot bearing are also installed. Exchange Only. There is a \$100.00 core fee if this is shipped out before yours is received.



B6375C 28-32 Price Set \$ 435.00

Flywheel to Crankshaft Bolt

This is the special bolt with a hole in the head for a safety wire lock. See Page Gen. 29 for safety wire. Grade 8 Bolts - Torque to 65 Ft. Lbs. Use the A7609 Retainer with these bolts.



A6376 28-48 4 x 7/16" - 20 x 13/16" bolt Price Set/4 \$ 6.95

Flywheel Housing Block Bolts

6 Piece set. Four center bolts (with safety wire holes) fit toward inner housing. Two longer bolts with lock washers connect the accelerator assembly to top of this housing.



Torque to 55 Ft. Lbs. - Grade 8 Bolts

A6378MB 28-31 4 7/16" - 14 x 1 1/16" Price Set/8 \$ 3.95
 2 7/16" - 14 x 1 11/16"

Clutch or Bell Housing to Flywheel Housing Bolts

Complete set of 11 bolts and 11 lock washers to attach the clutch housing to the flywheel housing.



11 x 3/8" - 16 x 1" bolts & lock washers Price Set/22 \$ 3.75
 A6380MB 28-31

Flywheel Gauge

Use the small bracket in this kit to determine if the flywheel is seated properly on the crankshaft. The large bracket bolts to the flywheel, then turn the flywheel so that you can be sure that the flywheel housing is correctly shimmed against the block. Both of these areas can cause vibrations if not properly done.

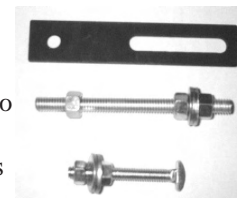

T6381 28-31 Price Set \$ 36.00

Flywheel Ring Gear

If you're overhauling your engine, replace this part. Heat with a torch - ring will then slip onto flywheel. Tapered teeth face rear of car. 112 Teeth.



A6384 28-31 Price Ea. \$ 24.95

Flywheel Housing Gasket

This fits between the flywheel housing and the back of the block to seal the rear of the motor.



A6396 28-34 Price Ea. \$ 0.75

Flywheel Dust Cover Inspection Plate

The inspection plate that attaches to the flywheel housing just behind the oil pan. Use A6398MB for bolts.



A6398 28-31 Price Ea \$ 9.50

Gen.112 Give us a call - 1-888-TRY-MIKE (879-6453) Have an "A" Day!

FLYWHEEL

Flywheel Dust Cover Inspection Plate Bolts

This set of 3 fine threaded bolts and lock washers hold the half-moon plate at the back of the oil pan.

3 1/4 -28 x 1/2" & lw's.



A6398MB 28-31 Price Set/6 \$ 0.90

Rear Main Janitor Diaper

A diaper for your Model A!! Catch that pesky oil that leaks onto your garage floor out of the rear main bearing with this black powder coated unit. Simply slips over the lower bell housing to flywheel housing bolts and one of the flywheel dust cover bolts. Goes on and off in seconds for a quick cleanup.



A6768 28-31 Price Ea. \$ 19.95

Flywheel Dowel Retainer

Fits between flywheel bolts and flywheel. Keeps flywheel dowels in place.

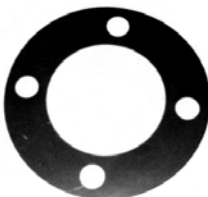

A7609 28-31 Price Ea. \$ 1.85

Flywheel Dowel Pin

These dowels line up the flywheel to the crankshaft.

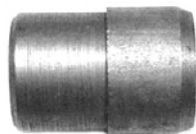

A6397 28-32 Price Pair \$ 2.95

Flywheel Shim

This shim fits between the flywheel housing and the block. You may need more than 1 set. See Vol. 4 - How to Restore your Model A - **A91021**.

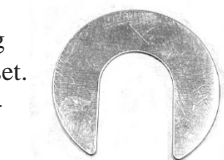

A6400 28-31 Brass .010 thick
Price Pair \$ 0.95

Flywheel Cotter Pin

Use this large cotter pin so that it hangs out of the hole in the bottom of the flywheel. Oil slowly collects in the flywheel housing and drips from the hole. If the hole is clogged by road dirt, the oil can eventually reach the clutch disc, causing the disc to slip. With the cotter pin through the hole, each bump will move the pin and keep the hole clear. Included in Cotter Pin Sets #37 & #37SS - See **Page Gen. 34. 3/16" x 1"**.

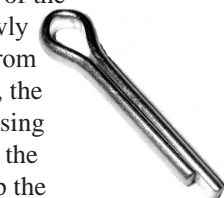

A6397A 28-31 Price Ea. \$ 0.25

FLYWHEEL

Mike's "A" FORD-ABLE Parts

VALVES

Specifications:

Lift:	.287" with .015" clearance
Seat angle:	45°
Seat width:	3.32"
Stem diameter:	.311"
Valve length:	5.677"
Head diameter:	1.537"
Valve opening diameter:	1-3/8"
Port diameter:	1-3/8"
Clearance, exhaust valves in guides:	.002"
Clearance, intake valves in guides:	.001" to .0015"
Valve lifter clearance:	.010" to .013"
Lifter diameter clearance:	.0015"
Valve guides:	I.D. - .3135"; O.D. - .5938"; length - 2.125" (early 2.375")
Valve spring:	O.D.-1.022"; free length 2-15/16"; comp. length - 2.250" (57-64 lbs); tension (closed) - 34 to 38 lbs.
Valve lifter:	A6500A (used w/A camshaft), length - 2.486" head diameter - 1.117"
Valve timing:	Intake opens 7-1/2° before TDC (Top Dead Center) Intake closes 48-1/2° after BDC (Bottom Dead Center) Exhaust opens 51-1/2° before BDC Exhaust closes 4-1/2° after TDC

Tappets - Adjustable Lifters

The very best available.
Self Locking Tappets uses a special split
bolt for locking. Need 8 Per car.

A6500 **28-34** **Price Set/8 \$ 71.95**



Adjustable tappets - case Hardened, carbon
impregnated outer surface. Double Nut Type.

A6500DN **28-34** **Price Set/8 \$ 49.95**



Valve Guide Removal Tool

The best on the market. This is a duplicate
of the K.R. Wilson tool used for the Model
A Engine. Using the bent rod type is risky
to valve stems.

T6511 **28-34** **Price Ea. \$ 13.50**



Valve Lapping Tool

Rubber suction cups stick to the valves, which in turn spins the
valve, grinding it into the seat. Use **A6509** Compound.



T6512 **28-31** **Price Ea. \$ 7.05**

Valve Grinding Compound

See above for the Lapping tool.
This compound is used to seat in
valves. 1.2 Oz. Tube.



A6509 **Price Ea. \$ 4.95**

Modern Valve Set

We have put together a complete set of our Modern Style. The
kits consist of **8 A6505MOD** Valves, **8 A6510MOD** Guides, **8
A6515MOD** Retainers, **16 A6514MOD** Keepers & **8 A6513
Springs**. No modifications required. This is the set we install in
all of our new engines - See Page Gen. 101.



A6505KIT **28-31** **Price Set \$ 150.00**

Stainless Valves

Longer lasting stainless steel
valves.

Best Quality available.

A6505SSA **28-31** **Price Ea. \$ 7.40**
A6505SSS **28-31** **Price Set/8 \$ 57.00**



A6505MODA **Modern** **Price Ea. \$ 10.60**
A6505MOD **Modern** **Price Set/8 \$ 80.00**

Valve Seats (Hardened)

Though not original equipment, these will
allow you to use unleaded fuel. Block must
be machined.

8 Needed.

A6506 **28-31** **Price Ea. \$ 3.95**



Mike's "A" FORD-ABLE Parts

Valve Guides

High quality reproduction of original split type valve guide. No USA Available.

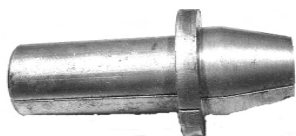

A6510A	28-34	Price Ea.	\$ 7.85
A6510	28-34	Price Set/8	\$ 61.95

Modern One Piece

Use A6505MOD Valve with this guide.



A6510MODA	Modern	Price Ea.	\$ 3.50
A6510MOD	Modern	Price Set/8	\$ 24.00

Valve Springs

High Quality springs lengthen the life of your valves. Always replace when redoing an engine.

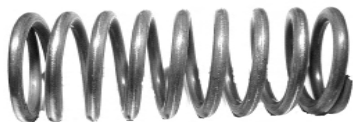

A6513A	28-34	Price Ea.	\$ 0.85
A6513	28-34	Price Set/8	\$ 6.50

Valve Spring Compressor Tool

This tool makes the job so easy. Place the hook over the manifold stud, and it acts as a pivot to pry the spring up to install the keeper.



T6513T	28-31	Price Ea.	\$ 41.95
--------	-------	-----------	----------

Valve Keepers

These fit on the valve stem to hold the valve spring.



A6514A	28-34	Price Ea.	\$ 1.50
A6514	28-34	Price Set/8	\$ 11.75



A6514MOD	Modern Keepers (Locks)	Price Set/16	\$ 4.80
----------	------------------------	--------------	---------

Use modern keepers and retainers with modern valves and guides only.



A6515MOD	Modern Retainer	Price Set/8	\$ 12.50
----------	-----------------	-------------	----------

Valve Cover Gasket



A6521	28-31	"A" Gasket	Price Ea.	\$ 1.25
A6521B	32-34	"B" Gasket	Price Ea.	\$ 2.25

Valve Cover Bolts

Set of 10 bolts and lock washers to hold the valve cover on. Torque to 15 - 20 Ft. Lbs.



A6520MB	28-31	10 x 5/16" - 18 x 3/4" & l.w.	Price Set/20	\$ 1.95
---------	-------	-------------------------------	--------------	---------

OIL PUMP

Specifications:

Type:	pump, splash, gravity feed
Crankshaft bearings:	gravity feed
Connecting rods:	splash
Camshaft bearings:	gravity feed
Oil pump type:	gear
Oil pump capacity:	9 pints/min at 1300 rpm
Oil pump pressure:	80-100 lbs.
Oil pump shaft:	1/2" diameter (in 5/8" bore), except '28s with 9/16" bore and undercut shaft (Model B used 5/8" bore w/undercut shaft)

Oil pump gear teeth to housing clearance:	.001" to .002"
Housing cover to face of gears clearance:	.001" to .002"
Drive gear to camshaft gear clearance:	.003" to .005"

Oil Pump Drive Bearing

Made to original specs.
The **A6551** gear slides into this housing.



A6541 **28-31** **Price Ea. \$ 18.50**

Oil Pump Drive Gear Sleeve Pin

This small pin holds the drive gear sleeve (**A6561**) into the drive gear shaft.



A6551P **28-31** **Price Ea. \$ 0.25**

Oil Pump Drive Gear

This is a critical piece to check when overhauling your engine. If yours is worn replace it. To remove this gear, remove the valve cover. Compress the oil pump drive gear spring about 1/2" from the top and then pull it out. The drive gear and housing can then be lifted out - take the pin out of the housing to release the drive gear.

Purchase Pin **A6551P** Separately. **It is imperative that this gear be replaced during engine restorations.**

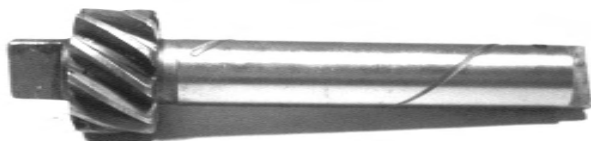

A6551 **28-34** **One piece construction**
Price Ea. \$ 22.50

Oil Pump Drive Gear Sleeve

This is pinned onto the oil pump drive gear to hold it in the housing. Includes **A6551P**.

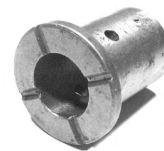

A6561 **28-31** **Price Ea. \$ 2.85**

Oil Pump Drive Gear Spring

This spring holds the oil pump drive gear unit in the valve chamber.



A6570 **28-34** **Price Ea. \$ 1.50**

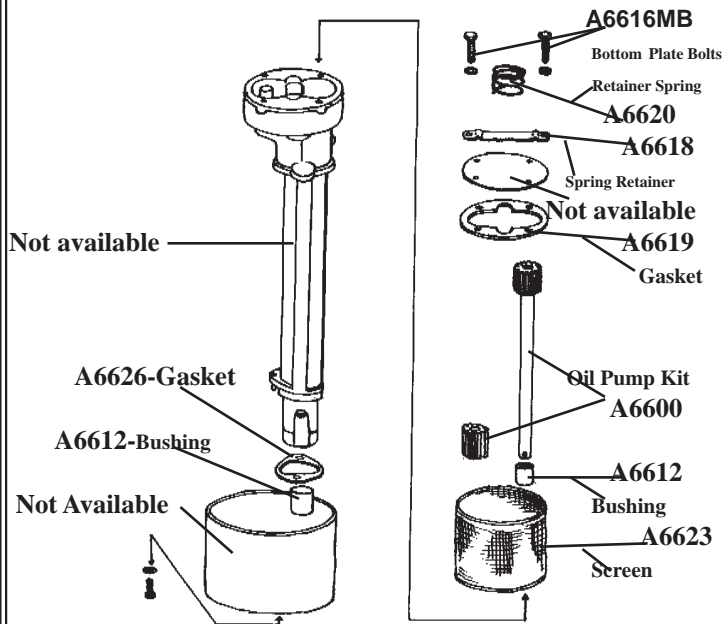

New Oil Pump

A brand new pump casting and gears ready to install. If your old pump casting is cracked or damaged you can now replace the entire unit.



A6600B **28-31** **Price Ea. \$ 99.00**

Mike's "A" FORD-ABLE Parts

OIL PUMP

Oil Pump Kit (Melling - The best Quality)

Rebuild your own oil pump with this kit. If you have an early pump, bore to .656 OD - you must use Bushings. Comes with everything that you need.



A6600 28-34 Price Set \$ 49.95

Dual Gauge Bracket (Water & Oil)

This gauge holder mounts around the steering column. Chrome Plated. Order the 1931 style for cars which have a column brace extending underneath the dash rail. An excellent copy of the old APCO gauge bracket.



A6538AC 28-30 Price Ea. \$ 59.95
A6538BC 1931 Price Ea. \$ 59.95

Dual Gauge Holder

Holder to be used with both the oil and temp. gauges. Mounts under the dash. Chrome plated.



A6537C 1928 - Mid '30 Oval Speedo Price Ea. \$ 43.50
A6537D June 1930 - '31 Round Speedo Price Ea. \$ 36.50

Oil Pressure Gauge

0-10 Gauge. Rex-A-Co. Order the oil line and spare bulb separately. 2" diameter gauge.



A6602 28-31 Price Ea. \$ 59.95
A6602A 28-31 Oil Line Kit Price Set/3 \$ 8.45
A6602AB Spare 6 Volt 4 Watt Bulb Price Ea. \$ 0.75

Oil Temp. & Pressure Gauge Strap

This bracket is mounted using the two lower instrument panel screws. No Drilling required. Black Painted Steel.



A6602OS 28-30 Oval Gauge Strap Price Ea. \$ 11.95



A6602RS 30-31 Round Gauge Strap Price Ea. \$ 11.95

Oil Pump Bushings

You will need 2 of these bushings for the oil pump shaft to ride in the housing. The AR has a little larger O.D. and is less common. 1" Long.

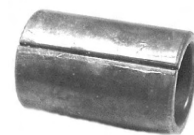

A6612AR 28-29 .656OD Price Ea. \$ 0.95

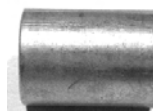

A6612 Nov 29-Till End 31 .625OD .500ID 1" Long Price Ea. \$ 1.75

Oil Pump Bottom Plate Bolts

This set of 4 fine-threaded bolts with lock washers is used to secure the bottom plate to the oil pump.



A6616MB 28-31 4 x 1/4" - 28 x 1/2" bolts & l.w. Price Set/8 \$ 1.45

Oil Pump Spring Retainer

This flat steel retainer holds the retainer spring (A6620) to the oil pump.

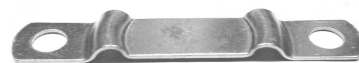

A6618 28-31 Price Ea. \$ 1.25

Oil Pump Gear Cover Gasket

This gasket goes between the pump housing and the cover plate on the bottom.



A6619 28-31 Price Ea. \$ 0.75

Oil Pump Retainer Spring

This is the spring that goes in the bottom of the oil pump.



A6620 28-34 Price Ea. \$ 1.15

Oil Pump Hole Plug

This is the special slotted pipe plug which was used on the side of the block near the oil pump to let you see if your oil pump was working. This is also used for the valve fitting on the inlet manifold to plug the hole. 1/8" Pipe thread. To hold in the oil pump while changing the pan gaskets - use A6701 - see Page Gen. 118.



A6621 28-31 Price Ea. \$ 0.65

Oil Pump Screen

Preformed with soldered edges, this screen goes in the oil pump.



A6623 28-31 Price Ea. \$ 3.95

Mike's "A" FORD-ABLE Parts

OIL PUMP

Oil Pump Screen Cover Gasket

Mike advises you to always keep a spare gasket for the oil pump screen cover.



A6626 28-31 Price Ea. \$ 0.25

Oil Return Pipe Mount Kit

This set has the 2 bolts with copper washers to mount the oil return pipe. See A6648B or C.



A6648MB 28-31 2 x 5/16" - 18 x 1 3/8" Price Set/4 \$ 1.25

Oil Return Pipe Gaskets

This pair of gaskets fit between the oil return pipe and the motor.



A6648 28-31 Price Pair \$ 1.85

Oil Pan Bolts

These 20 cadmium plated bolts attach the oil pan to seal around the crankshaft. Torque to 30 Ft. Lbs.



A6676MB 28-31 20 x 5/16" - 18 x 3/4" Price Set/40 \$ 4.50

Oil Pipe Mounting Bolt Washers



A6648C 1928 - June 1930 Copper Price Pair \$ 0.25
 A6648B June 1930 to End Brass Price Pair \$ 0.25

Oil Pan Timing Cover Packing

You'll need 2 of these 1 in the timing cover, the other in front of the oil pan. It is best to soak the packing in oil for a few days, then center into groove. Do not cut off excess, it will shrink.



A6700 28-31 Price Ea. \$ 1.25

Modern Front Oil Seal

This replaces the 2 piece rope type seal, no machining required on front seal only. We use these in all of our engines.



A6700M 28-31 Front Seal Price Ea. \$ 14.95

Oil Pump Pin

This handy little item will screw into the oil pump plug hole and hold the oil pump in place while installing the oil pan.



A6701 28-31 Price Set \$ 2.50

Rear Oil Pan Seal

This cork seal will need to be trimmed, it comes approx. 1/2" too long.



A6701A 28-29 13/32" Wide Price Ea. \$ 0.40
 A6701B 30-31 3/8" Wide Price Ea. \$ 0.40

"A" Very Full-Flow Oil Filter Kit

This is a complete full flow filter kit. No modifications needed to mount the special valve cover. ONLY works on 29-31 A's. On earlier ones the oil return pipe is too short.

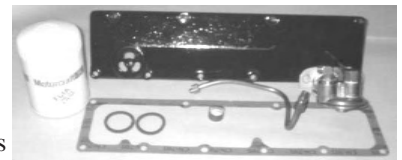

A6705F 29-31 This one really works Price Kit \$ 149.95

Oil Pan Clean Out Plate Screws

Early 28's need these bolts and lock washers to mount the clean out plate to the oil pan.



6 - 6 1/4" - 28 x 1/2" Bolts & l.w.s
 A6726MB 1928 Only Price Set/12 \$ 0.95

Oil Pan Clean Out Plate Gasket

This paper type gasket is for the '28 A's. Fits on the oil pan under the oil pump.



A6727AR 1928 Price Ea. \$ 0.75

1928 Oil Drain Plug - 7/8" -16

If you have an early '28 with a removable cleanout plate on the bottom of the oil pan, you'll need this larger diameter plug. Includes Gasket.



A6730A 1928 Steel Price Set \$ 4.95

Gen.118 Give us a call - 1-888-TRY-MIKE (879-6453) Have an "A" Day!

Oil Drain Plug - 3/4" -24

This cadmium plated plug fits on all "A" oil pans, except the early '28's. Don't forget to order your gasket - A6734.



A6730 29-34 Price Each \$ 2.00

Magnetic Oil Drain Plug

A built in magnet will grab any metal that may be floating around in the oil.



A6730M 09-31 Price Ea. \$ 3.50

Drain Plug Thread Repair Kit

Do you have a stripped oil drain plug hole? Use this special adapter which threads into the oil drain and cuts new threads for you. No need to remove the engine from the car. A new smaller drain plug is included with the set.



T6731 09-31 Price Set \$ 13.50

Weld in Thread Repair

These inserts can be welded into the pan giving you new threads if your old threads are stripped. The pan must be off of the car for installing.



A6733 09-31 Price Ea. \$ 7.75

Oil Drain Plug Gasket

This is a long-lasting fiber gasket. Does not fit early '28s.



A6734 28-34 Price Ea. \$ 0.30

Oil Drain Plug Gasket - Copper

Just like Ford used, these have asbestos sandwiched between copper.



A6734AR 1928 Price Ea. \$ 0.95

A6734C 29-31 Price Ea. \$ 0.70

Oil Dip Stick

Cadmium plated like the original. With loop handle - from January 1929. The loop style fits all blocks. Please make sure that your dip stick fits all the way down to the block for correct oil reading.

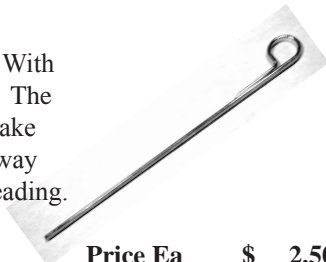

A6750 28-34 Price Ea \$ 2.50

Modern Oil Dip Stick

Reach the dip stick thru the floorboard!! No more removing the floorboards or crawling under the car to check transmission fluid levels. This is a "Must have" for every Model A owner that drives their Model A. A complete kit, which includes the E-Z Check Dip Stick riser and cap with Dip Stick, a floorboard hole pattern, and metal floorboard cover (similar to the floorboard battery cover). as E-Z as removing the transmission fill plug and screwing in the riser, insert the dip stick in the cap, cut the floorboard access hole and install the cover plate.

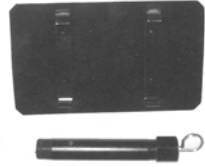

A6750MOD 28-31 Price Ea. \$ 25.00

Dipstick Wiper

A copy of an original accessory that was made by APCO. This stainless steel unit mounts under the head nut above the water inlet on the side of the block. Simple drag your dipstick thru the felt for easy cleanup.

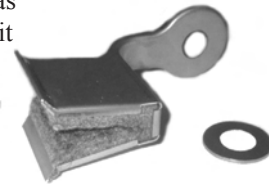

A6751 28-31 Price Ea. \$ 24.95

Oil Filler Tube

This quality filler tube presses into the block to fill the motor with oil. Excellent quality - **Best on the market - three separate baffles.**

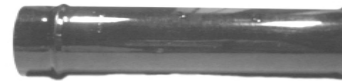

A6763 28-31 Price Ea. \$ 13.45

Oil Breather

Use this black powder coated breather with bare aluminum cap to replace the A6763 Oil Filler Tube. The cap is vented with a replaceable mesh filter, see A6763F. A very similar size to the original '32 - '34 4 cyl. fill tube.



A6763ACC 28-34 Price Ea. \$ 119.95

Oil Breather Replacement Filter

A replacement filter for the A6763ACC Oil Breather. This is the sponge that fits inside of the cap of the breather.



A6763F 28-34 Price Ea. \$ 3.75

Oil Breather

This little jewel helps keep your engine cleaner by directing oil vapors away from the engine. Easy installation instructions included.



A6764 28-31 Price Set \$ 27.50

Mike's "A" FORD-ABLE Parts

OIL PUMP

Oil Cap

If your cap is lost or damaged, replace it with one of these.

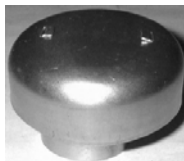

A6766	28-31	Steel	Price Ea.	\$ 3.75
A6766C	28-31	Chrome	Price Ea.	\$ 4.95
A6766BP	28-31	Powder Coated (Black)	Price Ea.	\$ 7.10

Engine Pans

Original equipment but frequently missing on restorations.

Mike also has the early 1928's.



A6775AR	Early 1928	Price Pair	\$ 60.00
A6775	28-31	Price Pair	\$ 46.75

Powder Coated Engine Pans

These pans have a satin black finish that has been baked on. This coating is gas and oil resistant. Ready to install onto the car.

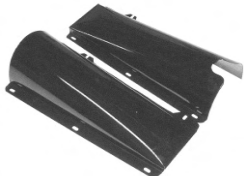

A6775P	29-31	Price Pair	\$ 61.75
--------	-------	------------	----------

***** MIKE'S TIPS *****

Engine Pans are a very important part of your cars cooling system. It allows the air from the fan to circulate and exit the louvers on your hood. Therefore helping to keep the exhaust manifold a little cooler.

Engine Splash Pan Mount Set

Set of 18 pieces to attach the engine pans to the frame. The original 1928 pans used bolts cross drilled for cotter pins.



A6775MB	28-31	6 1/4 X 28 X 1/2" Bolt & 1.w and 6 square nuts.	Price Set/18	\$ 2.70
---------	-------	---	--------------	---------

Oil Pan Gaskets

Complete set of gaskets needed for the oil pans.

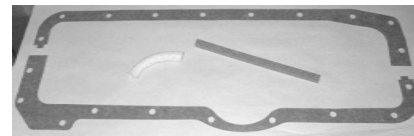

A6781	28-31	Paper	Price Set/4	\$ 4.75
A6781C	28-31	Cork / Compound - Imported from Europe	Price Set/5	\$ 5.65
V6781B	"B" Oil Pan Gasket		Price Set/4	\$ 7.50

Rear Main Janitor - Diaper

A diaper for your Model A!! Catch that pesky oil that leaks onto your garage floor out of the rear main bearing with this black powder coated unit. Simply slips over the lower bell housing to flywheel housing bolts and one of the flywheel dust cover bolts. Goes on and off in seconds for a quick cleanup.



A6768	28-31	Price Ea.	\$ 19.95
-------	-------	-----------	----------

TRANSMISSION

Specifications:

Gear and shaft material: Chromium alloy steel
 Gear ratios: High, 1 to 1 (100%)
 2nd, 6.89 to 1 (53.8%)
 Low, 8.75 to 1 (32.04%)
 Rev, (26.7%)

Bearings: main shaft front (ball) 1208;
 main shaft rear (ball) 1306;
 counter shaft short, Bower J241256;
 long, Bower J241246;
 pilot bearing, SKF 6203 2RSJ

Transmission case length: 6.560" to 6.565"
 Case front bearing hole: 3.1497" to 3.1507" diameter
 Case rear bearing hole: 2.835" to 2.836" diameter

New Transmission

We are proud to offer our brand new original style transmissions. Fully assembled and ready to bolt on. All new parts, including housing and bearing retainer. See **Page Gen. 125** to have your original transmission rebuilt.

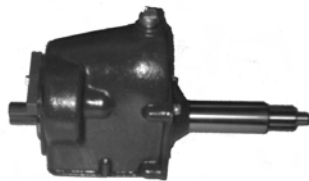

A7000N Price Ea. \$ 525.00

***** MIKE'S TIPS *****

It is recommended to change your 600 Weight every 1500 Miles - fill to the top of the filler plug - If your car has not run for some time, I would fill the gear case with half 600 Weight and half kerosene. Take the car out for a run and then drain this out - this should loosen all of the old oil and dirt.

600-W Oil (Now Available with Pour Spout)

This is the extra heavyweight oil you'll need for the rear end, the transmission, and the steering box. The rear end takes 1 1/2 qts; the transmission takes 1/2 qt; and the steering box takes 7 3/4 ozs for the 7 Tooth and 4 1/2 ozs for 2 Tooth.



A600W 28-31 1 Quart Price Ea. \$ 9.95

Brake Boot

This rubber boot fits over the brake shaft to keep out road dirt.



A7000EB 28-31 Black Price Ea. \$ 2.95

Emergency Brake Handle Boot Reinforcing Plate

Used on the Hand Brake Handle which was mounted on the left subrail next to the cowl panel. The plate secured the rubber boot at the base of the handle.



RAR212 Beginning to June 1928 Price Ea. \$ 9.50

Emergency Brake Handle Blank Off Plate

Use this to cover up the hand brake handle hole on the left subrail when the brake handle was moved from the left cowl subrail to the gear shift area. Beginning to **June '28**.



RAR213 1928 - June 1928 Price Ea. \$ 9.50

Gear Shift Boot

This black rubber boot fits over the gear shift to keep noise and dirt out of the car.



A7000GB 28-31 Price Ea. \$ 2.45

Gear Shift Boot Steel Retainer

Use this 5" diameter steel ring to hold the gear shift boot to the floorboard. Used on **early 1928's Only**.



RAR207 1928 Price Ea. \$ 11.15

Transmission Oil Filler Plug

This cadmium plated plug serves as both the oil fill and drain hole plug. **3/4 x 15/16 Pipe Plug - paint black.**



A7005 28-31 Price Ea. \$ 1.10

Bell Housing to Transmission Bolts

Set of 4 bolts with lock washers to bolt the transmission up to the clutch housing. **4 x 7/16" - 14 x 1 1/4" Bolts & l.w.**



A7006MB 28-31 Price Set/8 \$ 2.25

Transmission Main Drive Gear

The end of the shaft is where the Pilot Bearing **A7600** - (see **Page Gen. 132**) fits. If the shaft is worn more than .002 then it must be replaced, otherwise you will jump out of gear.



A7017B 28-31 Price Ea. \$ 108.00

TRANSMISSION

Mike's "A" FORD-ABLE Parts

Rear Wheel and Transmission Snap Ring

This little ring snaps in to hold the grease seal and bearing in place on the hub, you'll need 1 in each rear hub. This also fits into some transmission cases.



A1180 28-38 Price Ea. \$ 1.45

Transmission Ball Bearing (Import)

The main drive gear fits into this ball bearing. These are the best imports that we have found.



A7025 28-48 Price Ea. \$ 13.00

Transmission Baffle

The center of this baffle fits flat against the bearing so that there will be a 1/16" space at the outside edge of the baffle to bearing. This is not needed if you use a sealed bearing.



A7040 28-48 Price Ea. \$ 1.50

Transmission Main Drive Gear Spacer & Snap Ring

This is used on the main drive gear between the retainer and the ball bearing.



A7045B 28-31 Price Set \$ 3.75

Use A1180 - see Page Gen. 43 - as Main Drive Gear Baffle & Snap Ring in transmissions from May '29 - end with groove in case.

Transmission Main Drive Gear Bearing Retainer Bolts

This set of bolts holds the retainer tube to the front of the transmission case. 4 x 5/16-18 x 3/4 bolts & 1/w's.



A7050X 28-31 Price Set/8 \$ 0.80

Transmission Main Shaft

This is the main shaft on the transmission.



A7060 28-31 Price Ea. \$ 62.95

Transmission Main Shaft Collar

Also known as the pilot spacer, this goes behind the bearings or bearing baffle on the main shaft into the transmission case.



A7061 28-31 Price Ea. \$ 2.10

Transmission Spacer

Must be used on main shaft to avoid damaging the roller bearing. (A7118 - see Page Gen. 124).



A7063 28-31 Price Ea. \$ 0.95

Transmission Ball Bearing

This is the bearing for the main shaft. It's smaller than the A7025. These are the best imports that we have found.



A7065 28-48 Price Ea. \$ 9.75

Transmission Baffle

Center this baffle flat on the main shaft bearing with a 1/16" space at the outside edge of the baffle to bearing. This is not needed if you use a sealed bearing.



A7080B 29-31 Price Ea. \$ 1.45

U-Joint Rebuild Kit

You may be able to keep using your old U-Joint by replacing the cross, bushing and lock rings in this kit. Cannot be used if the U-Joint is riveted together.



A7084 28-31 Price Kit \$ 43.75

Rear Bearing Retainer Bolt

Drilled for Safety Wire. Install Grease fitting on the retainer at the bottom. Bolts hold the retainer to the rear of the transmission case. 4 x 7/16 - 20 x 1 Bolt. Don't forget the safety wire - See Page Gen. 29 in Restoration Supplies. Torque to 35 Ft. Lbs.



A7086X 28-31 Price Set/8 \$ 3.75

U-Joint Assembly

This U-Joint is complete and ready to install. 14 Oz. of grease should be pumped into U-Joint.



A7090 28-48 Price Ea. \$ 99.00

Gen.122 Give us a call - 1-888-TRY-MIKE (879-6453) **Have an "A" Day!**

TRANSMISSION

Mike's "A" FORD-ABLE Parts

Retainer Tongue
must fit
between Splines of
Universal
Joint

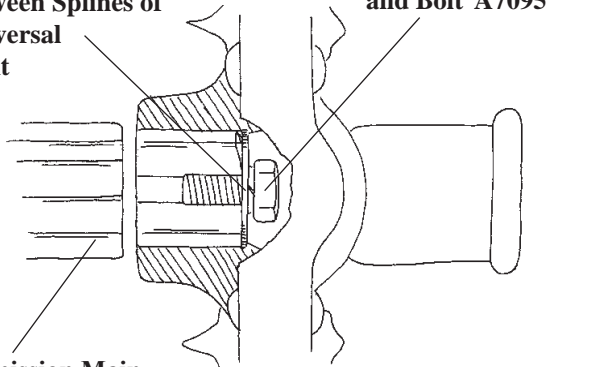

Transmission Main
Shaft - A7060

Universal Joint Assembly (A7090) - Page Gen. 122

Universal Joint Bolt Set

Set of bolts, nuts and cotter pins to assemble the universal joint housing caps. **6 3/8" - 24 x 1 7/32"** original thick head bolts drilled, 6 castle nuts & 6 cotter pins. **Two 3/8" - 24 x 1 bolts & nuts** to hold halves together. The top center bolt has a castle nut to the rear - all other bolts have castle nuts facing the front of the car.



A4520MB 28-31 Price Set/24 \$ 9.00

U-Joint Washer and Bolt

This is a special large diameter washer, bolt and lock washer to hold the universal joint on. The tabbed side of the washer goes in first. Torque to 22 Ft. Lbs. **3/8" - 24 x 1" bolt and washer.**



A7095 28-31 Price Set/3 \$ 1.75

U-Joint Gasket Set

Complete set of 2 felts and 2 cap gaskets needed for the U-Joints.



A4515GS 28-31 Price Set/4 \$ 2.25

Transmission Low and Reverse Gear

Precision machined low and reverse sliding transmission gear. Larger than A7101.



A7100 28-31 Price Ea. \$ 65.00

Transmission Second and High Sliding Gear

Precision machined second and high sliding transmission gear.



A7101 28-31 Price Ea. \$ 80.00

Transmission Cluster Gearshaft

Be sure to replace the reverse idler (A7140 - See Page Gen. 124) as well. Includes "O" Ring to prevent leaks.



A7111 28-31 Price Ea. \$ 8.95

Transmission Seal Kit

This kit seals both transmission shafts to minimize leakage. Not originally used, but a great idea.

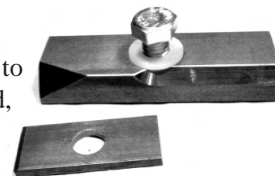

A7111S 28-31 Price Set/4 \$ 21.50

Front Transmission Seal

This seals the two holes where the shifting rails come thru. A common area for Oil leaks. Easier to install when transmission is out of the car. Fitting our A7202 from Page Gen. 127 would be an easier and less costly fix.



A7112S 28-31 Price Set \$ 37.50

Transmission Cluster Gear

Precision machined, ground and heat treated.

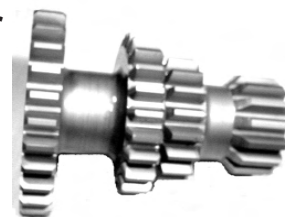

A7113 28-31 Price Ea. \$ 169.95

Transmission Cluster Bearing Spacer

This spacer separates the 2 roller bearing (A7118 - Page Gen. 124) which goes into the front of the cluster gear and A7121 - Page Gen. 124 which goes into the rear) inside the cluster gear.



A7115 28-31 Price Ea. \$ 1.75

TRANSMISSION

Mike's "A" FORD-ABLE Parts

Transmission to Drive Line Connection

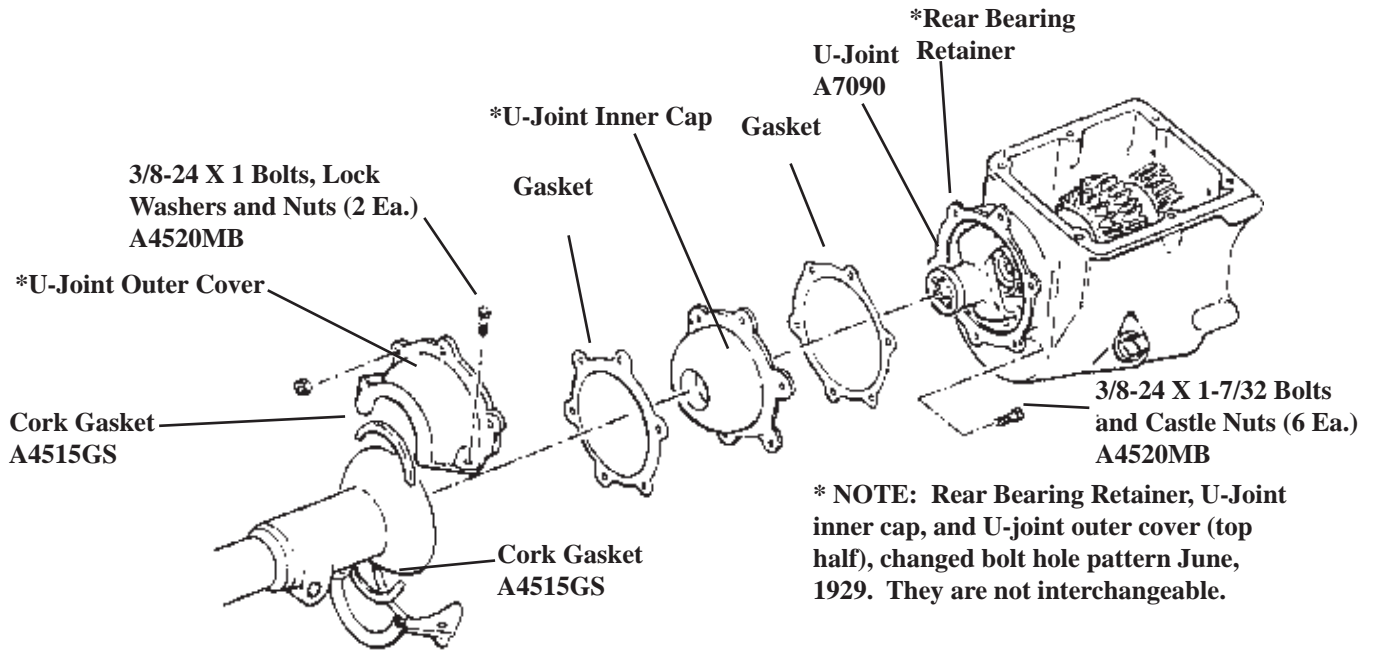

TRANSMISSION

Estimate for Rebuilding Transmissions Including Parts & Labor

2	A1180		\$ 1.45
2	A7005		\$ 1.10
1	A7017B	Main Drive Gear	\$108.00
1	A7025	Sealed Ball Bearing	\$ 13.00
1	A7040	Baffle	\$ 1.50
1	A7045B	Snap Ring	\$ 3.75
1	A7050X	Bearing Retainer Bolts	\$ 0.80
1	A7060	Main Shaft	\$ 62.95
1	A7061	Main Shaft Collar	\$ 2.10
1	A7063	Spacer - Main Shaft	\$ 0.95
1	A7065	Sealed Ball Bearing	\$ 9.75
1	A7100	Low & Reverse Gear	\$ 65.00
1	A7101	Second & High Gear	\$ 75.00
1	A7111	Cluster Gear Shaft	\$ 8.95
1	A7111S	Shaft Seal Plate	\$ 21.50
1	A7113	Cluster Gear	\$169.95
1	A7115	Spacer	\$ 1.75
2	A7118	Short Roller Bearing @ \$4.55	\$ 9.10
1	A7121	Long Roller Bearing	\$ 4.55
1	A7140	Reverse Idler Gear Shaft	\$ 7.45
1	A7141	Reverse Idler Gear	\$ 58.00
1	A7153	Gasket Set	\$ 3.75
1	M200	Can Green Engine Paint	\$ 4.65
		Total Parts	\$ 635.00
2	Hours	Labor @ \$45.00	\$ 90.00
A7000T Total Rebuilt Transmission on Exchange (with core received) Painted and ready to install			\$ 725.00
A7000TC Core Charge			\$ 50.00

Estimate for Rebuilding Shift Towers Including Parts and Labor

1	A7200K	Rebuild Kit	\$ 30.00
1	A7210	Gear Shift Lever	\$ 39.95
1	A7227	Gear Shift Lever Spring	\$ 2.95
1	A7228	Gear Shift Lever Spring Seat	\$ 2.25
		Total Parts	\$ 75.15
1 1/2	Hours	Labor @ \$45.00	\$ 62.50
A7000ST Rebuilt Shift Tower - Ready to Install - with core received.			\$ 142.65
A7000STC Core Charge			\$ 50.00

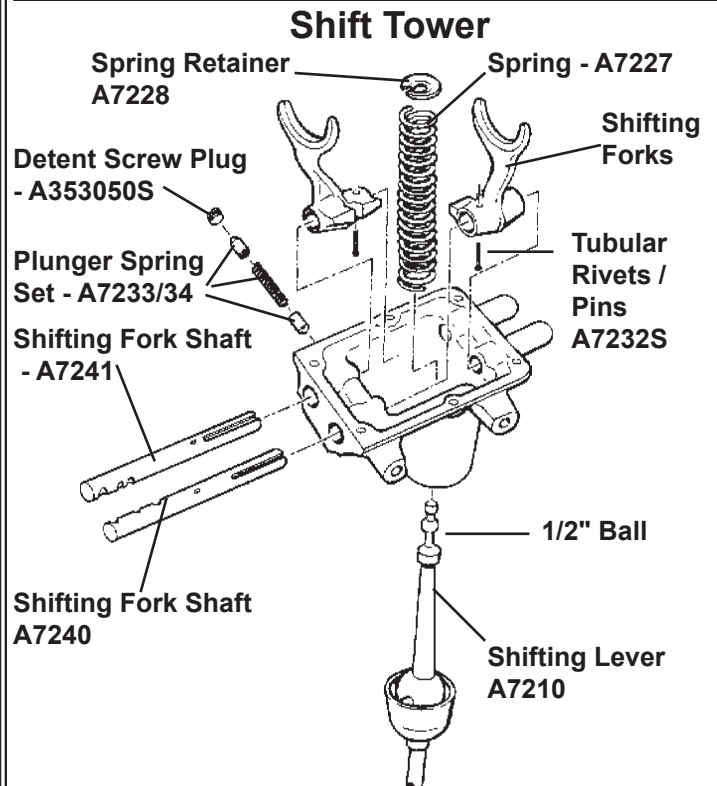

Mike's "A" FORD-ABLE Parts

Transmission Top Bolts

Complete set of bolts and lock washers to attach the transmission tower to the transmission. Torque to 11 Ft. Lbs.

4 5/16" - 18 x 3/4" 2 5/16" - 18 x 1 3/8"



A7222MB 28-31 Price Set/12 \$ 1.75

Transmission Gear Shift Lever Spring Removal & Installation Tool

This tool comes complete with instructions, for the removal or installation of your gear shift lever spring.



T7226T 28-31 Price Each \$ 37.95

Transmission Shift Lever Spring

The gear shift lever is held in place in the housing by this long spring.

6" Long.



A7227 28-31 Price Ea. \$ 2.95

Transmission Spring Retainer

Clip to hold the long spring in place on the gear shift lever.



A7228 28-31 Price Ea. \$ 2.25

Transmission Shifting Fork Pins

This holds the shifting forks on the gear shift shaft. 2 x 3/16 x 1 1/16 Tube Rivets.



A7232S 28-31 Price Pair \$ 0.95

Transmission Shifter Plunger/Spring

If your transmission slips out of gear, you probably need this set of two plungers and one spring. These fit in the transmission tower and slip into notches on the shifter shaft.



A7233/34 28-31 Price Set \$ 4.95

Transmission Gear Shift Housing Plug

This plug seals the hole where the plungers and spring (A7233/34) are inserted into the shift tower.

1/2 - 20 x 5/16".



A353050S 28-31 Price Ea. \$ 1.90

Transmission Shift Rail

This is the 3 detent shaft located in the transmission lid that secures the shifting fork so that it will slide the Low and Reverse gears.



A7240 28-31 Price Ea. \$ 12.00

Transmission Shift Rail

This is the detent shaft located in the transmission lid that secures the shifting fork so that it will slide the High and Intermediate gears.



A7241 28-31 Price Ea. \$ 12.00

Complete Transmission Tower Rebuild Kit

This kit contains all of the following needed to rebuild your Transmission Tower: A7233/34 - Shifter Plunger/Spring, A353050S - Gear Shift Housing Plug, A7232S - Shifting Fork Pins, A7240 - Shift Rail, A7241 - Shift Rail.

A7200K

Price Set \$ 30.00



Transmission Shift Rail / Bell housing Plug

Another Mike's original, this plug will help to eliminate oil leaks.

Need 2. See A7112S on Page Gen. 123.

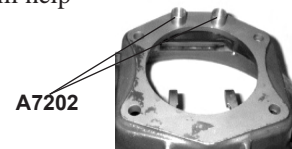

A7202

Price Ea. \$ 4.95

Transmission & Differential Hardware Kit

This set has all the exposed hardware needed to refurbish both the transmission and differential.

#36

28-31

Price Kit/85 \$ 8.75



Transmission Kit (Exposed)

This set has all the exposed hardware needed to refurbish the transmission.

#40

28-31

Price Kit/42 \$ 6.00



Differential Kit (Exposed)

This set has all the exposed hardware needed to refurbish the differential.

#41

28-31

Price Kit/42 \$ 5.75



Mike's "A" FORD-ABLE Parts

CLUTCH

Specifications:

Material:	Molded asbestos composition.
Pressure plate weight:	15 lbs.
Clutch disc weight:	2-1/2 lbs.
Pivot pedal pressure:	30 lbs.
Clutch facings:	9" diameter, 9/64" thick
Inside diameter:	5-3/4"
Total acting surface area:	75 sq. In.
Clutch pedal clearance (free play):	3/4" for multiple disc 1" for single
Clutch release bearing hub:	2.065" diameter
Clutch throw out bearing:	Bower 2065

Bell Housing to Flywheel Housing Bolts

Eleven 3/8 - 16 x 1 bolts.

Thick head with l.w.



A6380MB 28-31 Price Set/22 \$ 3.75

Clutch Housing to Transmission Case Bolts

Set of 4 bolts with lock washers to bolt the transmission to the clutch housing.

4 x 7/16 - 14 x 1 1/4 bolts and l.w.



A7006MB 28-31 Price Set/8 \$ 2.25

Clutch and Brake Pedal Mounting Shaft

For Multiple disc pedal shaft. Used from the beginning of production thru Nov '1928. Predrilled 3/4" diam. shaft.



A7506AR 28 - Nov. '28 Price Ea. \$ 17.85

Clutch and Brake Pedal Shaft

Made in the USA. This is the shaft for mounting the clutch and brake pedals. 7/8" Shaft.



A7506B Nov. 28 - 31 Price Ea. \$ 5.25

Clutch and Brake Pedal Shaft Collar

Fits at the end of the shaft - use pin A7509B.



A7507 28-31 Price Ea. \$ 3.65

Clutch and Brake Pedal Bushings

These bushings work on both clutch and brake pedals and the bell housing on the clutch release shaft. 4 Per Set.

Ream to .874

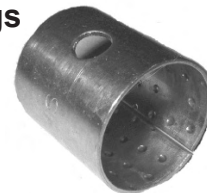

A7508A 28-31 Price Ea. \$ 1.20

A7508 28-31 Price Set/4 \$ 4.75

Pedal Bushing Reamer

This reamer will ream both bushings in each pedal or the bushings in the bell housing for the clutch release shaft. Ream to .874. See Mike's tips on Page 49.



T7508TR Price Ea. \$ 32.95

Pedal Shaft Pin

For Multiple Disc Clutch. Holds the collar onto the pedal shaft. Flat headed Pin.



A7509AR 1928 Price Ea. \$ 0.45

Pedal Shaft Pins

Holds the pedal shaft to the bell housing. Flat Rivet.

1/4 x 1 1/2 Headless groove Pin.



A7509A July '31 - End Price Ea. \$ 0.50

Pedal Shaft Collar Pin

Holds the collar to the 7/8" pedal shaft. Flat Headed Pin. 1/4" x 1 9/16"



A7509B June 29 - July '31 Price Ea. \$ 0.50

Brake and Clutch Pedal Shaft Set

Includes shaft, bushings, spring washer and collar pins. 7/8" Shaft.



A7506/09 Nov. '28-31 Price Set/8 \$ 10.95

Gen.128 Give us a call - 1-888-TRY-MIKE (879-6453) Have an "A" Day!

CLUTCH

CLUTCH ASSEMBLY

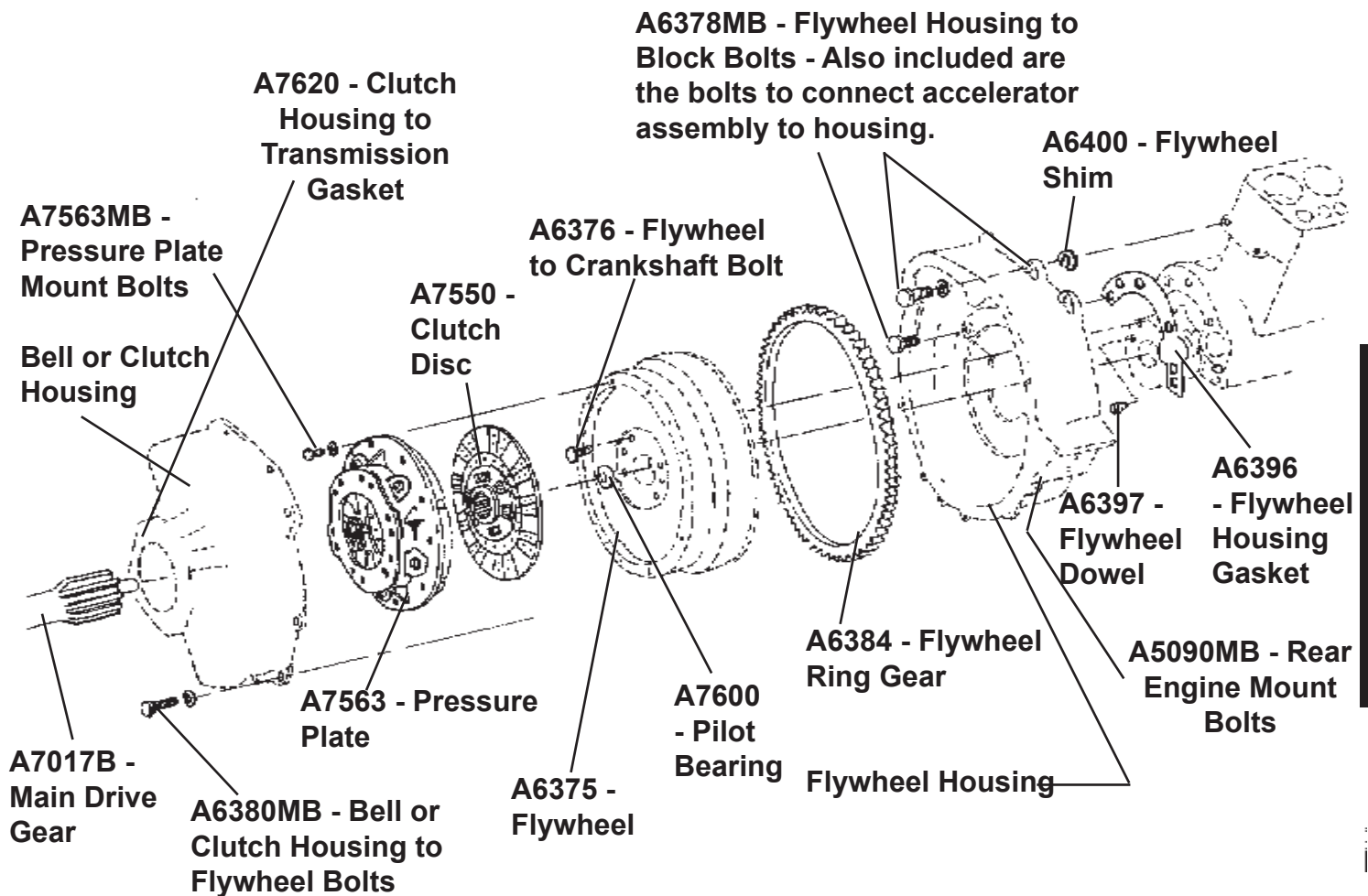

CLUTCH

Mike's "A" FORD-ABLE Parts

Clutch Release Shaft

Predrilled shaft. Keyed For the Early 1928 Multiple disc clutch.



A7510AR 1928 - June '29 Price Ea. \$ 26.25

Clutch Release Shaft

11" long but NOT for early '28 multiple disc clutch. Uses 2 bushings - A7508. .875" Dia.



A7510C June 29 - 31 Price Ea. \$ 5.95

Clutch Shaft Arm

Original style often cracked. This replacement goes on the end of the clutch release shaft.



A7511C 28-31 Price Ea. \$ 21.45

Clutch Release Shaft Plus Arm

These are made as a one piece unit - ready to install. The new design is made a little longer, reducing the clutch pressure by about 30%. This gives a softer pedal.

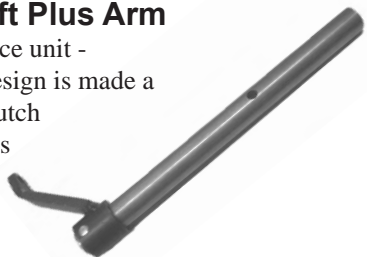

A7510WA Dec. 28-31 Price Ea. \$ 27.00

Clutch Shaft Spring Washer

This fits between the clutch and brake pedal on the clutch shaft.

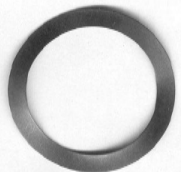

A7512 28-31 Price Ea. \$ 0.45

Clutch Shaft Release Pin with Key

This pin is used on the clutch shaft. 3/16 x 1 1/2 Plain Pin and #13 Woodruff Key.

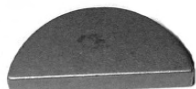

A7511A 1928 - June 29 Price Set \$ 0.70

Clutch Shaft Release Fork Pin

This pin serves two purposes - the clutch fork and also used for the clutch shaft arm. 5/16 x 1 1/4.



A7513 June '29 till End '31 Price Ea. \$ 0.60

Clutch Shaft Release Fork Pin with Key

3/16 x 1 1/4" Flat Headed Tubular Rivet with key # 13.



A7516A 1928 - June 1929 Price Set \$ 0.70

Clutch Release Fork

This is the fork that activates the throw out bearing when you depress the clutch.



A7515 June 29 till end Price Ea. \$ 15.00

Clutch Inspection Plate Bolts

Set of 2 machine bolts and lock washers to connect the inspection plate to the top of the bell housing.



A7518A 28-29 5/16 - 18 x 1/2 Bolts & lws. Price Set/4 \$ 0.40



A7518MB 30-31 5/16 - 18 x 3/8 Round Head Screw & Washers. Price Set/4 \$ 0.55

***** MIKE'S TIPS *****

Turn the Trunion Nut clockwise to decrease the clearance between the Clutch Disc and the Pressure Plate.

Adjusting Arm and Trunion

This adjusts the clutch. Pedal free play should be about 3/4" - 1". Connects to the clutch pedal and the clutch release shaft arm.



A7521-22 28-31 Price Set/2 \$ 7.95

Modern Adjusting Arm and Trunion

No need to pull out the clevis pin. Just loosen the jam nut, put wrench on adjusting nut and lengthen or shorten the rod, then tighten jam nut.



A7521/22MOD 28-31 Price Set/2 \$ 25.50

Mike's "A" FORD-ABLE Parts

Adjusting Arm

If your trunnion is still good, you can get the adjusting arm by itself.



A7521 28-31 Price Ea. \$ 6.00

Trunnion Nut

For the multi disc clutch on early '28's. 5/16" thread.

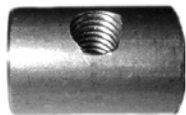

A7522AR 1928 - Nov. 28 Price Ea. \$ 2.00

Trunnion Nut

If your adjusting arm is still good, you can get the trunnion by itself. Special 3/8 - 24 Nut.



A7522 Nov. 28-31 Price Ea. \$ 1.80

Brake Clevis Pin

This special clevis pin is designed so you can hook the stop light switch to it. Used '28 thru July '29.

For July '29 to end, use Clevis Pin A2462 - See Page Gen. 50.



A2457 28-29 Price Ea. \$ 1.45

Clutch Disc

Excellent quality spring center type disc clutch.

No Exchange Needed.

PLEASE NOTE: The short side of the hub on the disc goes against the flywheel.

A7550 28-48



Price Ea. \$ 37.50

Clutch Align Tool

This helpful tool aligns the disc with the pilot bearing when you're installing a new clutch disc. Place the correct side of the clutch disc, (shortest side of hub) against the flywheel - install the pressure plate using 12 Bolts (A7563MB). Do not tighten the bolts - now - using your align tool, centre the clutch disc onto the pressure plate and carry on inserting the tool into the pilot bearing, then torque down the bolts to flywheel and remove the tool. See Page Gen. 5 for Torque Info.



T7550T 28-31 Price Ea. \$ 3.95

Clutch Inspection Plate

This is the plate that fits on the clutch housing, so that you can grease the throw out bearing.



M1007 28-31 Price Ea. \$ 10.95

Clutch Release Bearing Spring

This spring returns the clutch pedal and throw out bearing.



A7562 29-31 Price Ea. \$ 1.45

Pressure Plate

EXCHANGE ONLY.

Sorry, I must have your old one to send this rebuilt one.

Be sure to use Grade 5 bolts or better.



A7563 28-31 Price Ea. \$ 105.00
A7563CO Refundable Core Charge \$ 35.00

Pressure Plate Mounting Bolts

Set of 12 bolts and lock washers to attach the pressure plate to the flywheel. This is a Grade 5 bolt or better. Torque to 20 Ft - Lbs.



A7563MB 28-31 12 x 5/16" - 18 x 3/4" bolts & l.w. Price Set/24 \$ 2.25

1932 Modified Flywheel

This flywheel has been modified for a stock transmission. It includes the flywheel, clutch disc & pressure plate. They are resurfaced and balanced to reduce vibration. The ring gear and pilot bearing are also installed. Exchange Only. There is a \$100.00 core fee if this is shipped out before yours is received.



B6375C 28-32 Price Set \$ 435.00

Clutch Throw-out Hub

Your throw-out bearing mounts on this cast hub. These are imports. Sometimes reconditioned originals are available. Does not include grease fitting A353027 - see page Gen. 31.



A7561B 28-31 Price Ea. \$ 22.00

Clutch Throw-out Bearing

You should replace this permanently lubed bearing when you replace the clutch.



A7580 28-48 Price Ea. \$ 23.75

Mike's "A" FORD-ABLE Parts

Clutch Inspection Plate

Early '28's with the Emergency brake to the left had this plate installed in the floorboards to allow access to grease the clutch release bearing.



RAR230 1928 Price Ea. \$ 15.50

Flywheel Pilot Bearing

This sealed bearing presses in to the flywheel for the transmission shaft to fit into.



A7600 28-34 Price Ea. \$ 4.65

Flywheel Dowel Retainer

To keep the flywheel dowels in place, this plate fits between the flywheel bolts A6376 (See Page Gen .112) and flywheel.



A7609 28-31 Price Ea. \$ 1.85

Clutch Housing to Transmission Gasket

This gasket fits between the Clutch Housing and the Transmission. Use Permatex to seal - See Page Gen. 30.

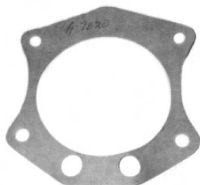

A7620 28-31 Price Ea. \$ 1.10

Do you need a
Discount on
your Parts??

Shop online at
www.mikes-afordable.com
and get a 5%
Discount!!

Gen.132 Give us a call - 1-888-TRY-MIKE (879-6453) Have an "A" Day!

CLUTCH

MODEL A IDENTIFICATION

1928 - 1929

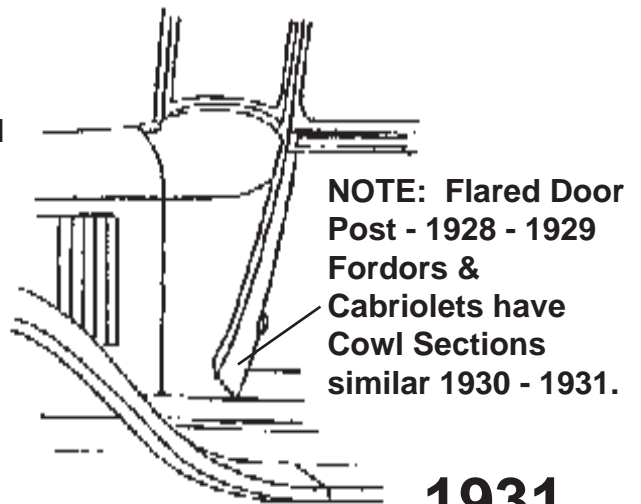
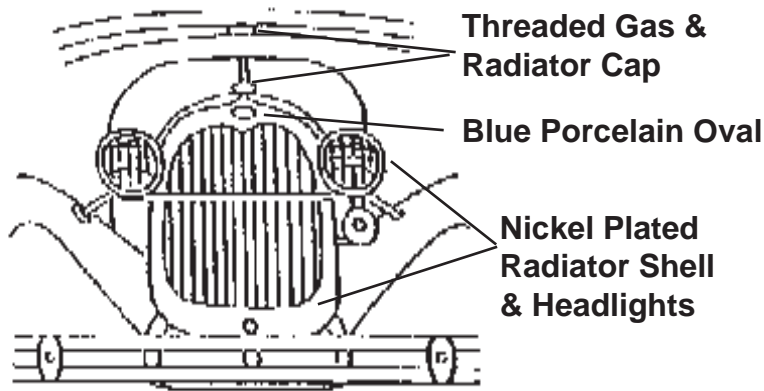

1930

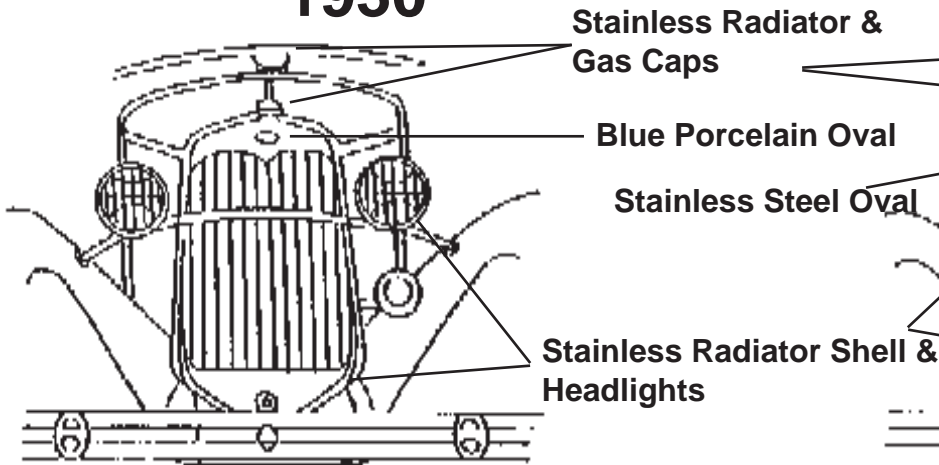

1931

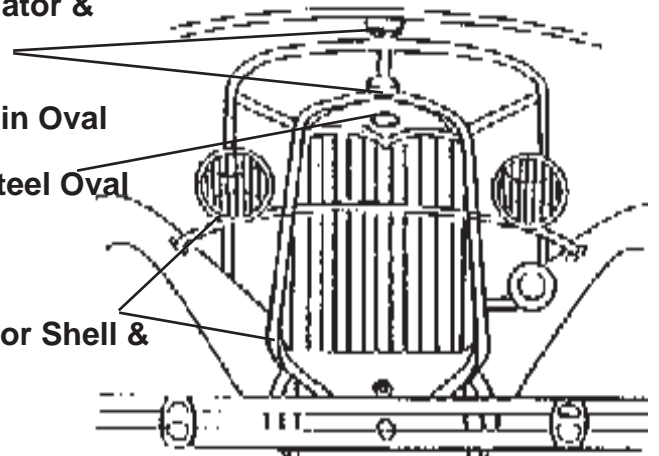

RADIATOR

RADIATOR

Specifications:

1928 Manufacturer:	Ford
1929 Manufacturer:	Flintlock, Long, McCord
Standard Radiators - 28-29	
Tubes:	Flat 1/2" Seamless
Number of tubes:	101 in 3 rows, staggered at 9/16" Centers
Number of fins:	5 Fins / Inch - 98 Fins
Core Size:	19-3/4 x 19-1/8 x 2-3/16"
1930-31 Manufacturer: Ford	
Standard Radiators - 30-31	
Tubes:	Flat 1/2" Seamless
Number of tubes:	95 in 3 rows, staggered at 9/16" Centers
Number of fins:	5 Fins / Inch - 100 Fins
Core Size:	20-1/8 x 18 x 2-3/16"
1928-29 Heavy Duty:	8 fins / Inch - 158 Fins
1930-31 Heavy Duty:	8 fins / Inch - 167 Fins

Radiator Brace Rod Bracket

Solder this bracket to the radiator to mount your brace rods to.

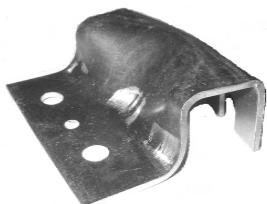

A8002TR 28-31

Price Ea. \$ 10.50

Radiator Necks

If your original neck has cracked, replace it with this brass neck and solder it into place.



A8001AN 28-29

Price Ea. \$ 23.75

A8001BN 30-31

Price Ea. \$ 23.75

Radiator Test:

1. Remove Bottom Hose
2. Plug outlet
3. Refill Radiator
4. Remove the plug. It should not take longer than 4 seconds to empty. If it does take longer, you know that you have clogged tubes.

For Quails, Locking Caps, MotoMeters See PageGen. 139 & Flags See Page Gen. 16.

Brassworks Radiator

The is the finest radiator available on the market - by far !!!

The '28 - '29 radiator is the only one on the market that has an exact duplicate of the original three piece top tank, correctly shaped threaded top filler neck, and unique wide mouth funnel shaped top inlet.

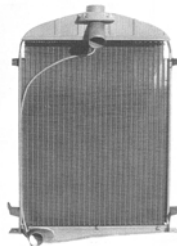
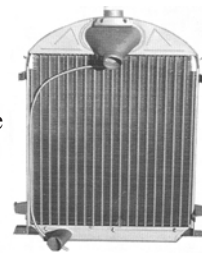

The '30-'31 radiator is the only one with an exact duplicate of the top filler neck that accepts all caps and quails (original or aftermarket), the one-piece top tank, top inlet, heavy - duty cowl rod bracket, and original bottom tank and bottom outlet.

Brassworks Radiators have 10 fins per inch, a 40% increase in fin surface and cooling capacity over the Standard. All radiators are equipped with hood rest brackets and have notched cores and three headlight wire harness tabs on the bottom tank to hold wires away from the fan.

A8005H	28-29	Price Ea.	\$ 600.00
A8005H1	30-31	Price Ea.	\$ 600.00

Radiator Shells

These are imports. The '28 and '29's are plated steel and are pretty good. Hood hinge clips are included, **NOT included** is A8200BS Screws (Page Gen. 136), A8210AS Grommet (Page Gen. 136), A8212A Emblem (Page Gen. 136), A16739A Lacing (Page Gen. 135) & A8216A Crank Hole Cover (Page Gen. 137).



A8200A	28-29	Primed - Black for Commercial Use	Price Ea.	\$ 115.00
A8200C	28-29	Chrome	Price Ea.	\$ 149.95
A8200N	28-29	Nickel	Price Ea.	\$ 165.00

Fan Shroud

A reproduction of an item that was originally supplied from the beginning of production thru **February 1929**. Optimizes the cooling efficiency of your radiator. It attaches to the back of the radiator and includes mounting hardware. Painted black enamel. These are fiberglass as steel are not available.



A8050A	28-29	Price Ea.	\$ 69.95
A8050B	30-31	Price Ea.	\$ 69.95

Radiator Cap

These are good reproductions of the original. Both caps include gaskets.

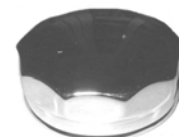

A8100A	28-29	Chrome over brass	Price Ea.	\$ 17.30
--------	-------	-------------------	-----------	----------



A8100C	30-31	Stainless Steel	Price Ea.	\$ 21.25
--------	-------	-----------------	-----------	----------

Mike's "A" FORD-ABLE Parts

Radiator Shell Lacing

Double beaded lacing - attaches to the radiator shell. Rivets included. 25 Rivets



A16739A	28-29	Price Set	\$ 6.75
A16739B	30-31	Price Set	\$ 9.00

Radiator Cap Gaskets

The '28 and '29 radiator caps use this treated leather gasket.



A8110A	28-29	Price Ea.	\$ 0.65
--------	-------	-----------	---------

Radiator Cap Gaskets

The '30 and '31 radiator caps use this treated leather gasket.

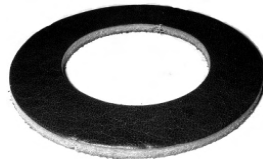

A8110B	30-31	Price Ea.	\$ 0.85
--------	-------	-----------	---------

Water Pipe Replacement Petcock

Unless you show your car, consider this solid brass petcock.



A8115RE	28-31	Price Ea.	\$ 5.75
---------	-------	-----------	---------

Water Pipe Original Style Petcock

If you are a purist, you'll want this excellent reproduction.



A8115OR	28-31	Price Ea.	\$ 8.75
---------	-------	-----------	---------

Radiator Mount Pads

You need these 2 rubber pads between the frame and radiator.

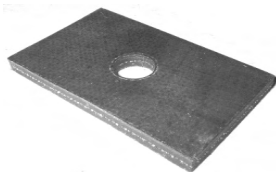

A8125	28-31	Price Pair	\$ 0.75
-------	-------	------------	---------

Radiator Mounting Springs

If you only need new radiator mounting springs, here they are.



A8130	28-48	Price Pair	\$ 1.00
-------	-------	------------	---------

Radiator Mount Kit

This complete authentic kit includes 2 each of pads, drilled bolts, castle nuts, spring and cotter pins.



A8130F	28-42	2 x 3/8 - 24 x 2" bolts	
		Price Kit	\$ 4.25

How to install A8130F

Mount Radiator with Bolt facing upwards, pad (A8125) between mounting ear and crossmember and spring (A8130) and Nut on top. Do Not overtighten bolt to fit cotter pin.

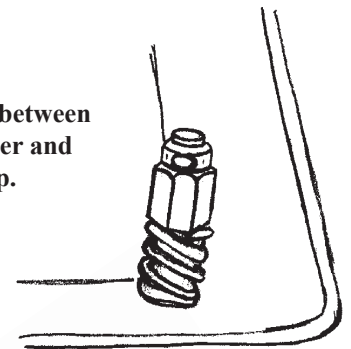

Radiator Brace Rods

In mid 1929, Ford switched to these solid rods. Nuts and washers included; should be painted black.

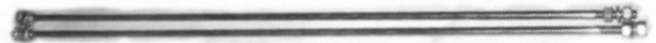

A8133A	28-31	Cadmium	
		Price Pair	\$ 8.50

Stainless Steel. Same as original.

A8133SS	28-31	Stainless Steel	
		Price Pair	\$ 24.50

B8133SS	1932	Stainless Steel	
		Price Pair	\$ 27.50

Radiator Brace Rod Brackets

These cadmium plated brackets attach to the firewall for the brace rods to hook onto. Painted body color. Order A8140MB (Page Gen. 136)



for Stainless Rivets.

A8140/41	28-31	Cadmium	
		Price Pair	\$ 2.95

Same as original except these are stainless steel.

A8140/41SS	28-31	Stainless Steel	
		Price Pair	\$ 12.95

Mike's "A" FORD-ABLE Parts

Stainless Steel Radiator Brace Rod Bracket Mount Set

Mount your brace rod brackets without riveting by using these 4 rivet headed bolts with 4 locking nuts.



A8140MB 28-31 Price Set/8 \$ 2.75

Radiator Shell Mount Set

This is a complete set of nuts, bolts and lock washers to attach the radiator shell to the radiator. '1928 Set includes 2 more Screws, l.w.'s and nuts for the fan shroud. '30-'31 used Cad. square nuts. 4 x 12-24" x 19/32" 1/2" wide square nut.



A8200AS 1928 Price Set \$ 2.50
A8200BS 29-31 Price Set \$ 1.70

Radiator Shell Grommet Sets

These 3 grommets fit the headlight and horn holes in the radiator shell.



1 Small and 2 Large.
A8210AS 28-29 13/16" Hole Price Set/3 \$ 2.25
A8210BS 29-31 15/16" Hole Price Set/3 \$ 2.25

Radiator Emblem

Original style blue porcelain emblem. Attaches to the radiator shell.



A8212A 28-30 Price Ea. \$ 19.95

Canadian Radiator Emblems

Original Style **Black** Porcelain Emblem. Limited Supply.



A8212CA 28-30 Price Ea. \$ 27.25

1931 Radiator Emblem

The '31 emblem is stainless steel with black lettering stamped on it.



A8212B 1931 Price Ea. \$ 17.50

Radiator Badge Screws

The long screws and nuts to mount the radiator badges to the radiator core.



A8213MB Any Year Price Set / 4 \$ 1.80

Hood Prop Kit

This stainless steel kit attaches to the radiator brace rods. Rubber coated levers flip out to set the hood on when open. Instructions Included.



A16613SS 28-31 Price Kit \$ 24.95

Hood Retainer (Front)

The center hood rod hooks onto this clip on the radiator shell.

Paint black.



A8220C 28-31 Price Ea. \$ 3.15

Hood Retainer Mount Set

A pair of tube rivets to mount the center hood rod brackets. Use rivet tool RA2022 on Page Gen. 28. 2 x 5/32 x 5/16".



A8220MB 28-31 Price Pair \$ 0.50

1932 Front Hood Retainer

You will need this special retainer for your radiator shell if you are using the 1932 style center hinge on your Model A.



B8220 1932 Price Ea. \$ 9.00

Hood Retainer (Rear)

This is the rear retainer for the hood. Paint body color.

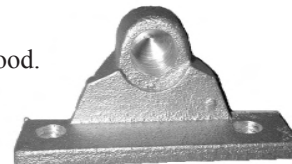

A16735A 28-29 Price Ea. \$ 5.10

Standard Hood Hinge Rod Retainer (Rear)

Same as above but for different years. Paint body color.

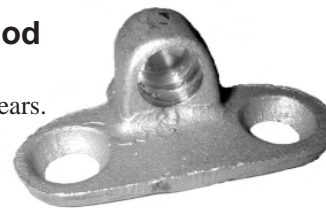

A16735B 30-31 Price Ea. \$ 4.95

RADIATOR

Mike's "A" FORD-ABLE Parts

Deluxe Hood Hinge Retainer (Rear)

This chrome retainer clamps over the cowl molding strip.



A16735C 30-31 Price Ea. \$ 7.95

1932 Style Rear Hood Retainer

When you use a 1932 style center hinge on your Model A, you will need this special hood retainer on the cowl. All hardware included.



B8221 1932 Price Ea. \$ 20.00

Retainer Mounting Screws (Rear)

Screws to mount the rear hood retainer to the firewall.



A16735AMB 28-29 2 x 12-24 x 5/8" round head
Price Set/6 \$ 0.95



A16735BMB 30-31 2 x 12-24 x 5/8" flat head
Price Set/4 \$ 0.95

Crank Hole Covers

These stainless steel cover are riveted to the radiator shell.

Rivets (A8216MB) Included.



A8216A 28-29 Price Set \$ 2.35



A8216B 30-31 Price Set \$ 2.35

Crank Hole Cover Mount Set

A tube rivet and lock washer to mount the crank hole cover. Use Rivet Tool RA2022 on Page Gen. 28.



A8216MB 28-31 Price Set/2 \$ 0.40

Water Outlet On Head

These are good quality cast water outlets.



A8250A 28-29 5 3/8" Price Ea. \$ 23.65

A8250B 30-31 6" Price Ea. \$ 20.05

Block Off Plate

If you are converting to a V8 Style Water Pump, then you will need to use this finned aluminum plate to block off where the outlet was on the head.



A8250BO 28-31 Price Ea. \$ 16.00

Water Outlet Gasket - Paper

This is a paper gasket for the water outlet.



A8255 28-31 Price Ea. \$ 0.50

Water Outlet Gasket - Copper

This is a copper-asbestos copper water outlet gasket.



A8255C 28-31 Price Ea. \$ 4.95

Water Inlet Bolts

This pair of black oxide dome headed bolts attach the water inlet to the block.

Torque to 40 Ft. Lbs.



A8255MB 28-31 2 x 7/16" - 14 x 1 3/8" bolt&l.w.
Price Set/4 \$ 3.90

Red Radiator Hose Set

Red, Like the original. Larger hose is for the top.

Bottom hoses are all 2 3/4" long.

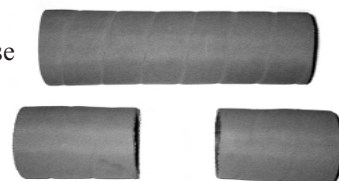

A8260/86A 28-29 6 1/4" Price Set/3 \$ 10.50

A8260/86B 30-31 8 1/2" Price Set/3 \$ 12.00

RADIATOR

Mike's "A" FORD-ABLE Parts

Black Radiator Hoses

Black with red rubber line. Larger hose is for the top.

Bottom hoses are all 2 3/4" Long.

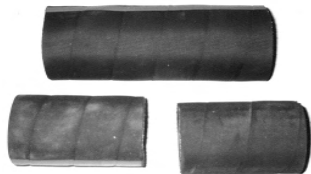

A8260/86AB 28-29 6 1/4" Price Set/3 \$ 10.50

A8260/86BB 30-31 8 1/2" Price Set/3 \$ 12.95

Radiator Hose Clamp Set

Set of 6 clamps. 2 larger ones are for the top. One set needed per car.



A8261/87 28-34 Price Set/18 \$ 5.75

Show Quality Radiator Hose Clamps

Set of Six clamps. Same gauge steel and cadmium plated as **A8261/87**, but die formed to the exact detail of the originals.

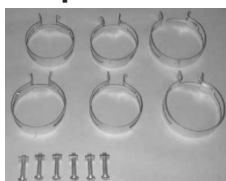

A8261/87OR 28-34 Price Set \$ 26.40

Radiator Hose Thermostat

This thermostat is welded to a 1" piece of thin-walled stainless pipe. Install at the top of the hose with the pointed end up. Will not cause leaks like the pronged ones can do.



A8270BR 28-31 160 temp Price Ea. \$ 12.60

Temperature Gauge

Stewart-Warner, black face.

90-100 Degrees Cold, 140-190 Degrees Driving temp, 190-250 Degrees - Danger.

Includes sensor line to gauge, either tap neck or use Pipe **A8273** or **A8273SS**.

Instructions included.



A8272 28-31 Price Ea. \$ 59.95

A6602AB Spare 6 Volt 4 Watt Bulb Price Ea. \$ 0.75

Temperature Probe Pipe

This 4" pipe has a nut welded in the center to fit the temp. Probe. Cut your upper hose and insert the pipe.

Set includes 2 clamps. Powder Coated.



A8273 28-31 Price Set/7 \$ 16.75

Temperature Probe Pipe

This 4" probe pipe does the same job as the **A8273** but is made of stainless steel to avoid rust, so it will not corrode your system. Comes with 2 hose clamps.



A8273SS 28-31 Price Ea. \$ 17.75

Dual Gauge Holder

This gauge holder mounts around the steering column. Chrome plated.



A6538AC 28-30 Price Ea. \$ 59.95

A6538BC 1931 Price Ea. \$ 59.95

Dual Gauge Holder

Holder to be used with both the oil and temp. gauges. Mounts under the dash. Chrome plated.



A6537C 1928 - Mid '30 Oval Speedo Price Ea. \$ 43.50

A6537D June 1930 - '31 Round Speedo Price Ea. \$ 36.50

Oil Pressure or Temperature Gauge Straps

Fits neatly underneath your instrument panel with your existing screws.



A6602OS 28-30 Oval Gauge Strap Price Ea. \$ 11.95



A6602RS 30-31 Round Gauge Strap Price Ea. \$ 11.95

Water Inlet Gasket

Copper Gasket for the water inlet.



A8280C 28-31 Price Ea. \$ 3.10

Water Inlet Gasket

Paper Water inlet gasket.



A8280 28-34 Price Ea. \$ 0.45

RADIATOR

Mike's "A" FORD-ABLE Parts

Water Pipes

Connects the bottom neck of the radiator with the water inlet on the sides of the block. Petcock does not come with Pipe. See **A8115RE** or **OR (Page Gen. 135)** for Petcock.

Powder Coated Black for durability.

A8291ARPC 28-29 Price Ea. \$ 12.50



A8291BPC 30-31 Price Ea. \$ 10.50

Show Quality Water Pipe

This unpainted stainless steel pipe has a mandrill that is bent just like the original. **The A8291 BOR and P will NOT work on the early powerhouse generator.**

A8291BOR 29-31 Price Ea. \$ 16.50

A8291P Powder coated Price Ea. \$ 22.00

A8291AOR Early 1928 - Stainless Steel Price Ea. \$ 16.00

A8291A Early 1928 - Powder coated Price Ea. \$ 22.00

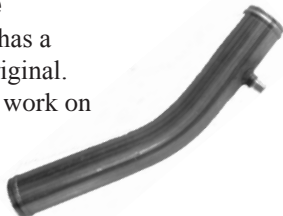

Heater Hook-Up Kit

Make your life a little simpler with the easy installation of a hot water heater in your Model "A". Replace your lower water pipe with the long pipe. Has a nipple for the original petcock as well as a nipple for the return hose with the fitting. The shorter pipe splices into your upper radiator hose and has a nipple for the temperature gauge as well as the water pickup connection. Pipes are all powder coated black and include clamps for the upper pipe. Upper fitting has a special scooped inlet to force water into the heater. See **Page Gen. 148** for heater.

A8274 28-31 Price Set \$ 49.95



Water Inlet

Use this aluminum inlet with an extra boss for heater hookup. Comes with plug and bolt for wire clip. Use this Inlet with the 6 or 12 Volt Heater (**A18480-6** or **A18480-12** - See **Page Gen. 148**) and the Heater Hook up Kit (**A8274**).

A8275ACC 28-34 Price Ea. \$ 59.95



See Page Gen. 15 & Gen. 148 for Heaters & Accessories.

MOTO METER

Motometers

Two styles, both chrome.

One is plain, the other has a wreath design. Ford used the wreath rim but both are correct. Includes Gasket **A18361MM (Page Gen. 141)** & Nut **A18361N (Page Gen. 141)**.

A18354CP 28-31 Plain rim Price Ea. \$ 45.10

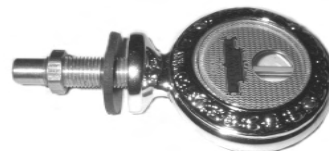

A18354CW 28-31 Wreath rim Price Ea. \$ 49.50

Motometer Locking Caps

Cap only. The early one was threaded while the latter has tabs but both lock in place with Allen screws.

A18360AR 28-29 Price Ea. \$ 44.00

A18360B 30-31 Price Ea. \$ 44.00



Locking Cap Repair Kit

Set includes two gaskets, two brass tabs and two allen screws.

A18360ARK 28-29 Price Set \$ 7.70

A18360BRK 30-31 Price Set \$ 7.70



Order Online Now and Save 5%

Visit our website for all your Model "A" needs.



www.mikes-afordable.com

MOTO METER

Mike Offers a 5% Discount on ALL online orders at www.mikes-afordable.com

Gen. 139

Mike's "A" FORD-ABLE Parts

Motometer-W-Locking Cap

These good quality MotoMeters with caps are available in all years in both the plain and wreath styles.

A18352AR
Shown



A18353AR	28-29 Plain rim	Price Ea.	\$ 85.00
A18353B	30-31 Plain rim	Price Ea.	\$ 85.00
A18352AR	28-29 Wreath rim	Price Ea.	\$ 85.00
A18352B	30-31 Wreath rim	Price Ea.	\$ 85.00

Motometer Wings

These are chrome-plated brass wings to mount on the motometer.



A18355WC	28-31 Chrome	Price Ea.	\$ 22.30
A18355WB	28-31 Brass	Price Ea.	\$ 22.30

Motometer or Quail Gasket

This special Red gasket (A18361R) goes between the locking cap base and the flip-up lid. The Black Washer (A18361B) seals the cap to the Radiator Neck.



A18361R	28-31 Red	Price Ea.	\$ 1.10
A18361B	28-31 Black Lower Washer	Price Ea.	\$ 1.10

Flying Quail

This is an excellent reproduction of the famous Ford accessory complete with locking cap.



A18385AR	28-29	Price Ea.	\$ 70.00
A18385B	30-31	Price Ea.	\$ 70.00

"Thermo" Quails

This design adds a thermometer which can hardly be seen from the front but is easily visible to the driver.



A18386AR	28-29	Price Ea.	\$ 85.00
A18386B	30-31	Price Ea.	\$ 85.00

Installation Instructions for Quail Locking Radiator Cap - 1930-31

These caps are the most authentic, most detailed reproduction of the famous "FLYING QUAIL" radiator cap ever made. To maintain your "Quail" in top condition, the following installation instructions should be followed.

1. NEVER open or close your "Quail" cap by grasping the bird and turning the cap. Use the ribbed cap edge for your gripping surface only.
2. Loosen the allen-head retainer screws and allow the brass retainers to drop from their seats. The retainers should have the long side facing the rim of the cap. If not, turn them into the correct position.
3. Test fit the cap to your radiator. Due to variances in radiator manufacturing, some radiators have slightly different neck construction from originals. You may have to file the neck slightly so the cap will seat properly.
4. Rotate the cap to properly align the rear hinge with the hood hinge rod. Hold in correct position and open cap to secure lock retainers. Again, check for proper fit in your radiator. If filing of inside lip is necessary, remove cap and do so.
5. Recheck fit, if all is OK, tighten allen head screws to lock retainers against the radiator neck. Make sure brass retainers are in proper position with long side facing the rim of the radiator neck so that they will lock properly.
6. Make final check of cap for tight fit, close cap, and admire your newly adorned "A".

It is recommended to periodically check the cap to be sure it stays tight on the radiator neck.

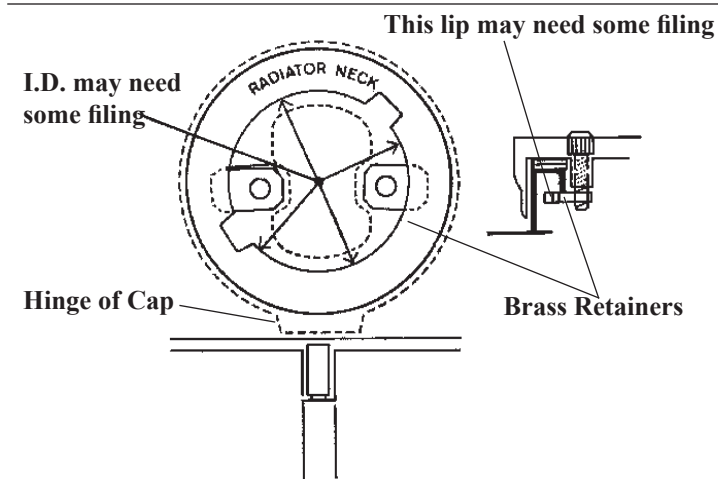

Replacement Quail Thermometers

This is a replacement thermometer for the thermo quail. Sorry these are not available for the Motometer.



A18355TQ	28-31	Price Ea.	\$ 21.25
----------	-------	-----------	----------

MOTO METER

Moto Meter Repair Kit

This repair kit includes all the lens, gaskets, and screws to rebuild your motometer.
12 Piece Set.

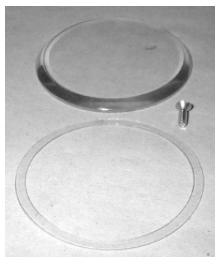

A18354RKSS 28-31 Price Set/12 \$ 16.45

Moto Meter Gasket

This gasket goes between the locking cap and the base of the motometer.

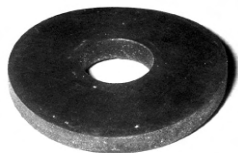

A18361MM 09-31 Price Ea. \$ 0.95

Moto Meter Nut

This is the brass nut that holds the motometer on the cap.



A18361N 09-31 Price Ea. \$ 1.05

Did you know that you qualify for a Discount?

Order online at www.mikes-afordable.com for 5% off.

This could add up to more than your shipping charges. Just imagine, FREE SHIPPING!!!

MOTO METER

Mike's "A" FORD-ABLE Parts

WATER PUMP

Specifications:

Water pump shaft:	5/8" diameter
Water pump shaft end play:	.006" to .010"
Radiator hose:	Upper, 2" diameter, 6-1/4" long ('28-'29), 8" long ('30-'31); Lower (2 pieces), 1-3/4" diameter, 2-3/4" long
4 blade fan:	At 1000rpm (fan), 62% increase in air flow, 82% increase in HP absorbed; at 2000 rpm, 55% increase in airflow, 47% increase in HP absorbed

In 2001 we totally redesigned our water pumps - so that they look like the original - with a unique feature - THEY ARE TOTALLY GREASELESS!! Fully guaranteed not to leak. No increase in price, comes with A8507A Gasket and A8510MB Fan Mounting Set.

Mike's Ultimate Water Pump

This is the finest pump available. Stainless steel shaft with leakless pack nut and pinned impeller. Brass for '28-'29 - Zinc for '30-'31. New Totally sealed unit - never needs greasing.



The front bearing is now increased to a sealed 1 1/2" Needle Bearing. All of the end play has been totally eliminated, pinned impeller and non Greasable Grease fittings are in place for show purposes only. Now has the ceramic rotating seal as in new cars. There cannot be a better water pump on the market today. Includes Gasket **A8507** and Fan Mounting Set **A8510MB** - Page 143. **NO EXCHANGE NEEDED**

A8501B	28-29	Brass	Price Ea.	\$ 140.00
A8501Z	30-31	Zinc	Price Ea.	\$ 140.00

Original Water Pump

This is the original style. Needs greasing every 500 miles. Includes Gasket **A8507** and Fan Mounting Set **A8510MB**.



A8501	28-31	Price Set	\$ 76.95
--------------	--------------	------------------	-----------------

Complete "B" Water Pump

Comes with gasket and nut, key and pin set. Used with 3 hole "B" heads.



B8501	B Pump	Price Set	\$ 159.00
--------------	---------------	------------------	------------------

Stainless/Leakless Rebuild Water Pump Kit

The best rebuild kit. Includes a stainless steel shaft, impeller installed and leakless pack nut. Gaskets and everything else you need to repair your old waterpump.



A8591SSB	28-29	Brass	Price Set/18	\$ 62.15
A8591SSZ	30-31	Zinc	Price Set/18	\$ 62.15
A8591RBK	"B" Pump - 1932		Price Set	\$ 90.05

Here is a list of what you get in our Pump Kits:

	"A"	"B"
A8510MB	\$ 1.10	\$ 1.10
A8511SS	\$21.00	\$48.00
A8507	\$.35	\$ 1.25
A8511C	\$ 3.50	\$ 3.50
A8513SS	\$ 1.30	\$ 1.30
A8520B	\$16.00	\$16.00
A8523LK or LKZ	\$17.95	\$17.95
A8540A x 2 @ \$0.40	\$.80	\$.80
A8530	\$ 2.85	\$ 2.85
A8535	\$ 2.50	\$ 2.50
A8542 x 2 @ \$0.30	\$.60	\$.60
A8554 x 2 @ \$0.30	\$.60	\$.60
A353027	\$.60	\$.60
A8501FIT	\$ 3.00	\$ 3.00
Total	\$72.15	\$100.05
You Pay	\$ 62.15	\$ 90.05

Water Pump Housings

Mike has the new water pump housings available in case yours have cracked or been damaged. For "B" rebuild kits see A8591RBK above.

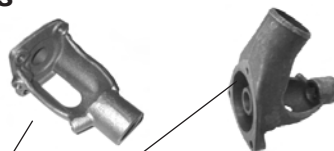

A8505BR	A Pump	Price Ea.	\$ 36.75
B8501CAST	B Pump	Price Ea.	\$ 70.00

Water Pump Adapter

This adapter is used if you are wanting to run a 3 bolt style V8 Water Pump on a 4 bolt style model "A" head. Aluminum. Will not work on "B" 4 cylinder pumps.



A8501ADP	Price Ea.	\$ 59.95
-----------------	------------------	-----------------

Mike's "A" FORD-ABLE Parts

WATER PUMP

Water Pump Cover

This will help keep your engine compartment clean from pump grease or water. Tight fitting leather.

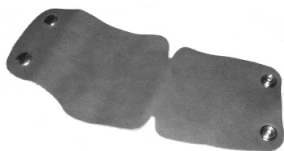

A8501COA	28-31	Tan	Price Ea.	\$ 9.50
A8501COB	28-31	Black	Price Ea.	\$ 9.50
A8501COG	28-31	Green	Price Ea.	\$ 9.50

Water Pump Studs, Nuts & Washers

Set of 4 studs, nuts and lock washers to mount water pump.

Studs screw into the head.

3/8" - 24 Nuts and Lockwashers



A8501MB	28-31		Price Set/12	\$ 3.00
---------	-------	--	--------------	---------

Water Pump Mounting Bolt Set

Try out this mounting set the next time that you need to remove your water pump. Water pump will slide up to eliminate moving your radiator. One of Mike's great ideas.



A8508	28-31		Price Set/8	\$ 6.40
-------	-------	--	-------------	---------

Water Pump Grease

Modern, multipurpose grease can be used for water pump and chassis. Water proof and withstands high temps.



A8500	Any Year		Price Ea.	\$ 6.25
-------	----------	--	-----------	---------

Water Pump Wrench

Specially designed for the water pump packing nut. Do not overtighten.

Not needed with Mike's Ultimate water Pump.

T8501W 28-34



			Price Ea.	\$ 1.60
--	--	--	-----------	---------

Water Pump Grease Fitting

Special brass fitting with a screw on cap for rear bushing assembly of the pump.



A8501FIT	28-31		Price Ea.	\$ 3.00
----------	-------	--	-----------	---------

Water Pump Impeller

Impeller only. Install so that base of impeller is 8 3/8" from the front end of the shaft.



A8501IMP	28-31		Price Ea.	\$ 5.75
----------	-------	--	-----------	---------

Water Pump Fan Mounting Set

Set of castle nut, woodruff key, and cotter pin to mount fan.

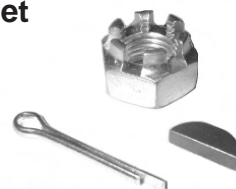

A8510MB	28-31	7/16" - 20	Castle nut 5/8" wide	
			Price Set/3	\$ 1.10

Water Pump Shaft with Impeller

These shafts already have the impeller pressed on and pinned.



A8511SS	28-31	Stainless	Price Ea.	\$ 21.00
---------	-------	-----------	-----------	----------



V8501SS	1932	"B"	Price Ea.	\$ 48.00
---------	------	-----	-----------	----------

Water Pump Gasket



A8507	28-31		Price Ea.	\$ 0.35
A8507A	28-31	Black - As Original	Price Ea.	\$ 0.50
A8507B	B Pump		Price Ea.	\$ 1.25

Water Pump Thrust Collar and Washer

This thin collar with a nylon washer goes on the front of the pump to keep the shaft and fan from moving back and forth.



A8511C	28-31		Price Set/3	\$ 3.50
--------	-------	--	-------------	---------

Water Pump Stainless Thrust Washer

As above, but made of stainless steel for long-lasting use.



A8513SS	28-31		Price Ea.	\$ 1.30
---------	-------	--	-----------	---------

Mike's "A" FORD-ABLE Parts

WATER PUMP

Water Pump Rear Bushing Assembly

Steel with brass insert. Mounts on rear of pump, pack nut screws into this. This is the original style.



A8520 28-31 Price Ea. \$ 7.50

Water Pump Rear Bushing Assembly-Brass

Same as A8520 but solid brass so it will never corrode. Also fitted with a double V ring seal to help prevent leakage.



A8520B 28-31 Price Ea. \$ 16.00

Water Pump Replacement Pack Nut

Not as good as original but it's the only steel replacement available right now. This is very much like the original.



A8523RE 28-31 Price Ea. \$ 2.95

Water Pump Nuts

Good quality, heavy nuts available in brass for '28-'29 or zinc for '30-'31. These are similar to the originals.



A8523B 28-29 Brass Price Ea. \$ 9.75

A8523Z 30-31 Zinc Price Ea. \$ 9.95

Water Pump Leakless Pack Nut

This nut uses modern seals and O rings to eliminate water pump leaks. This is the best way to go.



A8523LK 28-29 Brass Price Ea. \$ 17.95

A8523LKZ 30-31 Zinc Price Ea. \$ 17.95

Water Pump Roller Bearing

The shaft rides on this bearing in the nose of the pump. Need 1.



A8530 28-31 Need 1 Price Ea. \$ 2.85

Water Pump Bearing Sleeve

Press this sleeve into the nose of the pump for this bearing to ride in. Need 1.



A8535 28-31 Need 1 Price Ea. \$ 2.50

Water Pump Packing - Teflon or Lead

This is a 13" piece of teflon rope style packing that can be used with any original water pump.

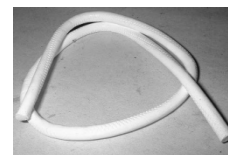

A8524T 28-31 Teflon Price Ea. \$ 3.60

Ford changed to Graphite Lead packing in 9/'29; it causes less friction and won't score the shaft. Split type is used if you're adding to existing packing.

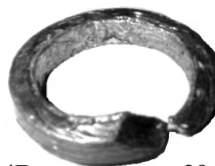

A8524B 29-31 Split Lead 1/8" thick Price Pair \$ 3.25

Water Pump Bearing Cup Washer

You need two of these cup-shaped washers, one on each side of the front roller bearing.



A8540A 28-31 Need 2 Price Ea. \$ 0.40

Water Pump Bearing Felt

Fits into the cup washer.



A8542 28-32 Need 2 Price Ea. \$ 0.30

Water Pump Bearing Flat Washer

This flat washer goes up against the roller bearing.

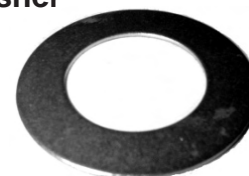

A8554 28-31 Need 2 Price Ea. \$ 0.30

Mike's "A" FORD-ABLE Parts

FAN

Specifications:

Fan belt width: 5/8"
 Fan belt length: 42 7/8"
 Fan cooling surface: 374 sq in
 Fan speed: 1-1/2" times engine rpm
 Fan delivers about 855 cfm at 1000 rpm, about 24 m.p.h.
 4 blade fan: At 1000 rpm, 62% increase in air flow, 82% increase in HP absorbed; at 2000 rpm, 55% increase in air flow, 47% increase in HP absorbed.

***** MIKE'S TIPS *****

For Fan Belt Removal - Remove the Pulley Bolt from the Generator Pulley. The shaft is tapered and should slide off to release the belt. For Installation of the Belt - Slide the Pulley onto the generator shaft and tighten the pulley bolt. Belt Tension should be 1/2" give between the fan and the Generator Pulley.

2 Blade Cast Aluminum Fans (Balanced)

One-piece construction makes this the best fan available.
Black Powder Coated.



A8600A 28-31 Price Ea. \$ 48.95

Four Blade Fan

This four-blade fan was not an original production item but it is possibly more efficient. It's steel with reinforcing ribbing.



A8600B 28-31 Price Ea. \$ 56.65

Plastic Fan (6 Blade)

Machined hub, modern style. Bolts onto hub. Bolts included. Perfect for long distance travel and extra cooling.



A8600P 28-31 Price Ea. \$ 61.25

Fan Knock Off Tool

This innovative little tool will help you to remove your fan. Simply thread this special nut onto the end of the shaft, hold the fan and give the tool a couple of good hits to brake the fan loose from the shaft.



T8600T 28-31 Price Ea. \$ 1.95

Fan Belts

Good quality black fan belt for your A. Have one handy before your old one breaks.



A8620A	28-31	Black	43" Long	Price Ea.	\$ 9.50
A8620F	28-31	Ford Script - Black - Show Quality		Price Ea.	\$ 13.65

Fan Mounting Set

Set of castle nut, woodruff key and cotter pin to mount fan.
 7/16" - 20 Castle Nut 5/8" Wide.



A8510MB 28-31 Price Set/3 \$ 1.10

Give Mike's your email address. Order confirmation and tracking info right at your fingertips.



Run about or Stripdown??



Hmmm, should I paint it red or green?



MANIFOLD

**** Mike's Tips ****

In order to prevent any cracks in the manifold, bolt your intake and exhaust together and check the surface with a straight edge. If the surface is not entirely straight, take your manifolds to a local machine shop and have them mill them flat.

Intake Manifold

This excellent quality manifold can be used on all A's. Has the boss in the casting to connect vacuum wiper to. All manifolds are drilled but do come with a plug if you do not need the hole for the earlier electric wiper. Paint Ford Engine Green.



A9425D

March 1929 till end 1931

Drilled and tapped
Price Ea. \$ 85.00

Intake to Exhaust Bolts

2 bolts with lock washers to attach the intake to the exhaust manifold.
2 x 5/16" - 18 x 3/4" bolts & l.w.



A9425MB

28-31

Price Set/4 \$ 1.00

Exhaust Manifold

Replace your leaking or warped manifold with this excellent one.

Torque to 50/55 Lbs.
See Page Gen. 147 for gasket.

A9430

28-31

Price Ea. \$ 89.95



Cast Iron Header

This header is designed to be used with the weber down draft carburetor - it gave our speedster an extra 10 m.p.h. This set comes with header pipe, collector and spacers.

See Page 165 for Down Draft

Carburetor.

A9430H

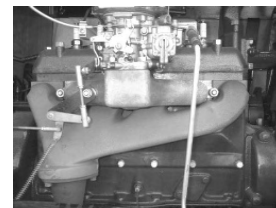

Price Kit \$ 250.00

Mike's "A" FORD-ABLE Parts

Engine Paint

You'll need one spray can of this Model A Ford green paint if you're touching up your engine; two if you are repainting. 11 Oz Can.



M200 28-31 Price Ea. \$ 4.65

Heat Resistant Spray Paint

Resists heat up to 1500 deg. for manifold and mufflers. Spray on clean metal, no primer needed. Spray only enough to cover metal, do not over paint. 11 Oz. can.



A5240 Black Price Ea. \$ 9.95
A5241 Cast Iron Gray Price Ea. \$ 9.95

Manifold Nuts

A nice set of 4 brass nuts to attach the manifold. Torque to **50 ft/Lbs.**
4 x 7/16 - 20 Nuts



A9430N 28-31 Price Set/4 \$ 3.95

Manifold Studs

Set of 4 studs to screw into the block to attach the manifold.



A9431 28-34 Price Set/4 \$ 3.25

Manifold Stud Washers

These extra heavy washers help hold the intake and exhaust manifolds in place. The crown of the washer goes away from the motor.



A9443 28-34 Price Set/4 \$ 4.50

Gland Rings - for New Exhaust only.

If you use the regular gasket, you'll want these which fit into the manifold to form a tight seal.



A9440 28-31 Price Set/4 \$ 2.00

Copper / Asbestos Manifold Gasket - A9433

Nuts - A9430N

Studs - A9431

Stud Washers - A9443

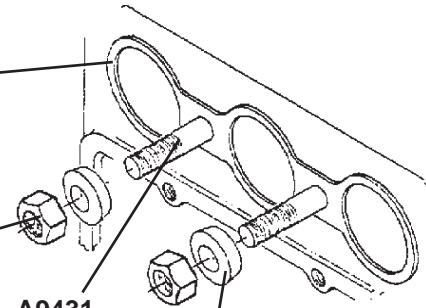

Thanks to Les Andrews for the use of his drawings.

Manifold Gasket

This is a one-piece asbestos with steel covering gasket.



A9433F 28-31 Price Ea. \$ 5.65

Manifold Gasket

This is a two-piece flat asbestos gasket.

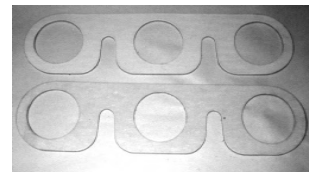

A9433 28-34 Price Pair \$ 2.65

Copper Manifold Gaskets

For the show car, these 2 piece gaskets are copper with asbestos in the middle.



A9433C Jan 29- May 31

Price Pair \$ 11.30

A9433C2 May 31 till End



Price Pair \$ 11.30

MANIFOLD

Mike's "A" FORD-ABLE Parts

Intake & Carburetor Gasket

This gasket fits between the carburetor and the intake manifold.



A9447 28-34 Paper

Price Ea. \$ 0.30



A9447C 28-31 Copper

Price Ea. \$ 3.10

Waffle Style Manifold Heater

This heater has two mounting holes that are 7 1/16" apart from center of holes. Heater door valve is not included.



A18478WS 28-31 Price Ea. \$ 79.95

Manifold Heater

This takes the chill off a morning. It bolts onto the manifold with no cutting or welding and has a firewall valve to control the heat. **The valve A18479S is included plus extra clamps for fitting.**



A18478S 28-31 Price Set \$ 72.50

Manifold Heater Valve

Replacement firewall valve only. It mounts directly on the firewall to let you control the heat coming through. Needs a 2" hole cut into the firewall. **No extra clamps. This is included with A18478S.**



A18479S 28-31 Price Set \$ 10.50

Manifold Heater Door Patch Panel

4 1/2 x 8" panel fills the area where the heater hole was usually cut. Original gauge steel, with the exact contour reinforced ribs.

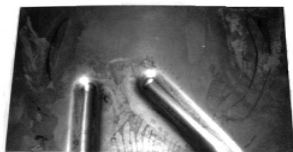

A18478P 1930 - May 31 Price Ea. \$ 12.95

Heaters

Do you get cold when you drive your car in the winter? Now there is a solution to keep you warm, so you can drive your car, year round. This universal aftermarket heater, uses the coolant system for its heat. You will need the Heater Hook Up Kit below (A8274) for installation.

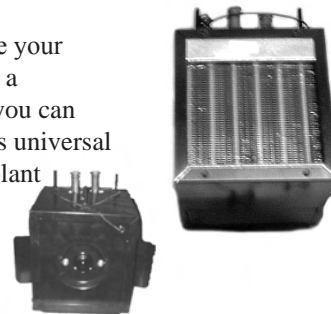

A18480-6 6 Volt Price Ea. \$ 160.00

A18480-12 12 Volt Price Ea. \$ 133.50

Heater Hose & Fittings Set

When installing the A18480-6 or 12 heater, you will need to install this kit. Kit includes 8' of 3/4" ID hose, an elbow shut off valve that has a 3/8" pipe thread on one side, and a 3/4" hose barb on the other, a 3/8" to 1/2" OD pipe adapter and 4 hose clamps. See A8274 for Heater Hook-up Kit.



A18480K 29-31 Price Kit \$ 27.00

Heater Hook-Up Kit

Make your life a little simpler with the easy installation of a hot water heater in your Model "A". Replace your lower water pipe with the long pipe. Has a nipple for the original petcock as well as a nipple for the return hose with the fitting. The shorter pipe splices into your upper radiator hose and has a nipple for the temperature gauge as well as the water pickup connection. Pipes are all powder coated black and include clamps for the upper pipe. Upper fitting has a special scooped inlet to force water into the heater.



A8274 28-31 Price Kit \$ 49.95

Water Inlet

Use this aluminum inlet with an extra boss for heater hookup. Comes with plug and bolt for wire clip. Use this Inlet with the 6 or 12 Volt Heater (A18480-6 or A18480-12) and the Heater Hook up Kit (A8274).



A8275ACC 28-34 Price Ea. \$ 59.95

ZENITH CARBURETOR ASSEMBLY

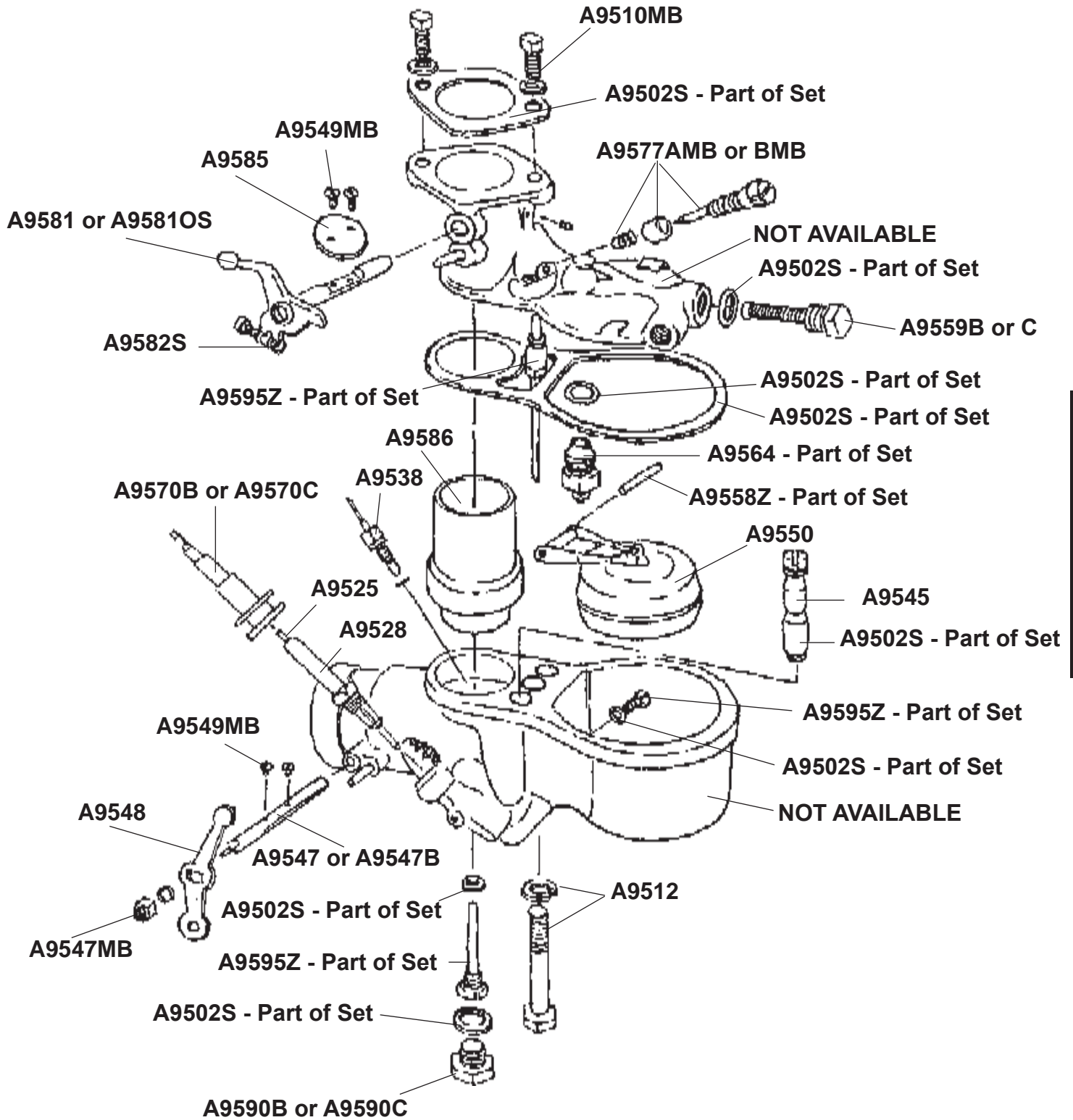

MANIFOLD

CARBURETOR

Specifications:

Throat size:	1"
Float level:	5/8" below upper body machined surface
Main jet:	.037" I.D. (#63 drill bit)
Cap jet:	.037" I.D.
Compensator jet:	.035" I.D. (#65 drill bit)
Idling jet:	.021" I.D. (# 75 drill bit)

For helpful books on Carburetors See Page 9.

Helpful Hints on Carburetors

Our new Zenith Carburetors and our rebuilt Zenith & Tillotson Carbs are tested on cars before they are shipped - and yet it is still the most frequent item to be shipped back to us.

99% Of the time, the problem is not in the carb, but the gas line fitting that fits into the carb. Either the ferrule is damaged or the line is just not fitted correctly, causing the gas to leak out and run down around the carb. This in turn gives the impression that the carb is leaking at the gasket.

If your ferrule is leaking order a new line - **A9240B or C** - See Page ____.

Another major problem is the condition of the Shut Off Valve, so often they are the original, and are in need of replacement or repair. Check to make sure that both of these areas are carefully looked at before blaming your carb, and un-necessarily starting a repair or rebuild job that could have been avoided.

Zenith Carburetor Gasket Kit

This gasket kit is for the Zenith carburetor. Including all correct small red gaskets.

Order **A9595Z** for complete kit.



A9502S 28-31 Price Set/8 \$ 1.50

"B" Carburetor Gasket Kit

Zenith 1932 B carburetor.

Complete with all gaskets.

Order **A9595B** for complete kit.



A9502B 1932 Price Set/6 \$ 1.50

Tillotson Carburetor Gasket Set

This gasket kit is for the Tillotson pot metal carburetor.

Complete with all gaskets.

Order **A9595T** for complete kit.



A9502T 28-31 Price Set/5 \$ 1.50

Marvel Carburetor Gasket Kit

This is the correct gasket set for the old Sears / Marvel Carb



A9502M Price Set \$ 8.00

Zenith Carburetor Kit

This kit contains the following items needed to rebuild the original Zenith

Carburetor:-

- A9502S** Gaskets
- A9525** Adjusting Needle
- A9532** Adjusting Needle Seat
- A9534B** Main Jet
- A9538** Cap Jet
- A9542** Idle Jet
- A9564BV** Float Valve
- A9575** Compensator Jet
- A9577BMB** Idle Mixture Screws
- A9590C** Drain Plug



PLEASE NOTE: You need to order **A9545** (see Page Gen. 152) Secondary Well Separately.

A9595Z 28-31 Price Set/20 \$ 19.50
A9595B 32 "B" Carb Kit Price Set \$ 41.25

Tillotson Carburetor Kit

This kit contains the following items needed to rebuild a Tillotson Carburetor:-

- A9502T** Gaskets
- A9525** Adjusting Needle
- A9558T** Float Pin
- A9590C** Drain Plug
- A9564** Float Valve

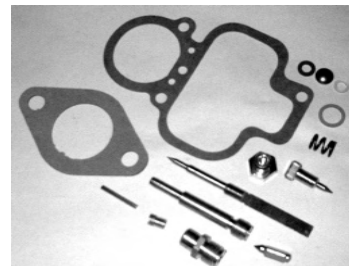

Bowl Jet, Clean out plug and Idle mixture Screw included in kit, but not sold separately.

A9595T 28-31 Price Set/15 \$ 15.00

Zenith Carburetor Complete Rebuild Kit

Everything you need except the housing to totally rebuild a Zenith 1 Carburetor. Can be used for Zenith 2, but the channel plugs may vary in size.



A9511ZKT 28-31 Price Set \$ 119.00

CARBURETOR

Tillotson Carburetor Complete Rebuild Kit.

Everything you need except the housing to totally rebuild a Tillotson Model X Carburetor.



A9595TKT 28-31 Price Kit \$ 77.50

Carburetor to Intake Bolts

Set of two bolts and lock washers to attach the carburetor to the intake. 2 x 5/16" - 18 x 3/4" bolts & l.w.



A9510MB 28-32 Price Set/4 \$ 0.50

Carburetor Stop Pins

These are special knurled pins that press into the carburetor to connect the choke and throttle to the driver controls.



A9506P 28-31 Price Pair \$ 1.10

Carburetor Rebuilding Wrench

This is a copy of the KR Wilson tool used to rebuild Zenith Carburetors, has a 5/16" deep socket on one end for the cap jet and a 9/32" socket for the idle jet.



T9511 28-31 Price Ea. \$ 11.50

"B" Zenith Adapter Kit

Everything you will need to run a "B" carb on your "A". The kit contains a gasket, specially machined bolts & fittings.



B9510K 28-31 Price Set \$ 23.75

"B" Choke Adapter Kit

This kit gives you a larger bore mounting gasket with machined bolts that allow the carb to pivot, which in turn allows the "A" choke rod to align.



B9510S 28-31 Price Set \$ 12.25

Carburetors - New or Exchanged

Please note that a refundable core charge will be added for rebuilt carburetors. This will be refunded if your core is received within 30 days of the shipping date.

This is a brand new exact copy of the original Zenith-1 carburetor. Paint Zenith Carb Bodies, dull black for show.

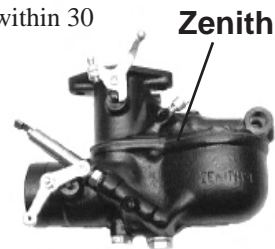

A9510 28-31 New Zenith Price Ea. \$ 335.00

A9510ZE 28-31 Rebuilt Zenith - Exchange Price Ea. \$ 200.00

A9510ZC Zenith Core Price Ea. \$ 95.00

Tillotson

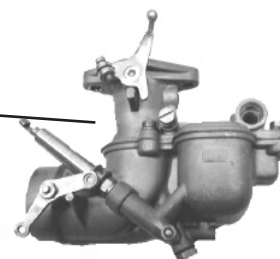

A9510TE 28-31 Rebuilt Tillotson - Exchange Price Ea. \$ 120.00

A9510TC Tillotson Core Price Ea. \$ 25.00

A Great Alternative Carburetor to use whilst doing a restoration or testing your Model A. These Marvel Carbs are all rebuilt and tested and run like a dream.

Marvel (Sears or Western Auto)

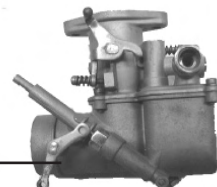

A9510ME 28-31 Rebuilt Marvel - Exchange Price Ea. \$ 90.00

A9510MO 28-31 Rebuilt Marvel - Outright Price Ea. \$ 105.00

A9510MC Marvel Core Price Ea. \$ 15.00

Two Barrel Down Draft Carburetor and Intake Manifold

A Great new alternative to those who would like some extra OOMPH.

Included in this kit is the Carburetor, Intake Manifold, a complete mounting kit, an air cleaner which stands an impressive 2 1/2" Tall and assembled linkage. If you feel a fuel pump is needed, order the A9510FP6 or 12. You will need to add a choke set up - See Page Gen. 152. Don't miss the Cast Iron Header on Page Gen. 146.

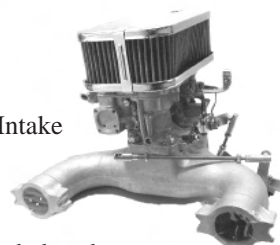

A9510DOW 28-31 Price Set \$ 495.00

Mike's "A" FORD-ABLE Parts

Replacement Air Filter for Weber Down Draft Carburetors

Top Quality filter for our Weber Down Draft Carburetors. See Page Gen. 151.



A9510DF Price Ea. \$ 12.50

Weber Down Draft Carburetor Gasket Set

This is the replacement gasket set for our Weber Down Draft Carburetors. See Page Gen. 151.



A9510DRK Price Set \$

Weber Choke & Adaptor for the Down Draft Carburetors

This set attaches to the original choke rod support under the tank.



A9510CA Price Set \$ 40.00

Electric Fuel Pump for Speedsters

This pump mounts below the carburetor with the bolt that mounts from the fender to the frame. Kit includes fuel pump, fuel filters, all gas lines, fittings, clamps and hoses. 12 Volt - Negative Ground.

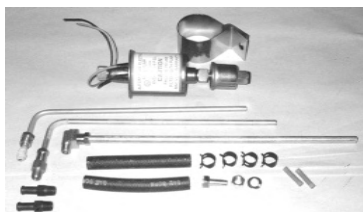

A9510FP6 28-31 6 Volt - Positive Ground Price Set \$ 80.00

A9510FP12 28-31 12 Volt - Negative Ground Price Set \$ 80.00

Carburetor External Hardware

This set contains an air shutter shaft, nut, 4 choke and throttle screws, idle stop screw and bowl bolt.



A9585X 28-31 Price Set \$ 1.65

"B" Carburetor Hardware Kit

1932 - 1934 Zenith Carburetor hardware kit.



B9585X 32-34 Price Set \$ 3.95

Carburetor Adjustment Needle Housing

Made for the Zenith & Tillotson carburetor to protect the adjustment needle. Correct 13/32" Hex Size.



A9528 28-31 Price Ea. \$ 7.60

Carburetor Adjustment Needle - Tillotson & Zenith

This brass adjustment needle works off your choke rod. It is critical for good performance - inserts into A9528. Push needle hard into housing and screw together.



A9525 28-31 Price Ea. \$ 3.30

Carburetor Adjustment Needle Seat

For the early Zenith carburetors, adjustment needles fit with this brass seat. See A9575 (Page Gen. 154) for Compensator Jet.



A9532 Jan '28 - Jan '30 Price Ea. \$ 2.20

Carburetor Main Jet - Zenith & Tillotson



A9534B 28-31 Zenith Price Ea. \$ 4.25



A9534T 28-31 Tillotson Price Set/2 \$ 6.95

Carburetor Cap Jet - Zenith

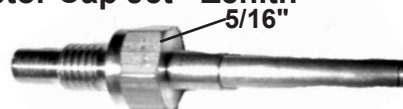

A9538 28-31 Price Ea. \$ 4.65

Carburetor Idle Jet - Zenith



A9542 28-31 Price Ea. \$ 3.65

Carburetor Secondary Well

For the Zenith carburetor.



A9545 28-31 Price Ea. \$ 4.90

CARBURETOR

Mike's "A" FORD-ABLE Parts

Carburetor Choke Shaft Lever - Zenith or Tillotson

This cadmium plated lever is for the choke shaft.



A9548 28-31 Price Ea. \$ 2.25

Carburetor Choke Shaft

The choke shaft is available in standard and oversize but you must ream the hole for the oversize.



A9547 28-31 Standard Price Ea. \$ 5.00

A9547B 28-31 Oversize Price Ea. \$ 4.00

Carburetor Choke Arm Nut & Washer - Zenith or Tillotson

Special thicker nut connects the choke arm to the choke shaft.

8-36 Thread - Includes a Star Washer.



A9547MB 28-31 Price Set/2 \$ 0.60

Carburetor Choke Plate (Zenith)

This stamped steel choke plate, or butterfly, is cadmium plated.



A9549 28-31 Price Ea. \$ 1.95

Carburetor Butterfly Screws

This is a set of four fine-threaded screws to attach the choke and throttle butterflies to the shafts.



A9549MB 28-31 4 x 5/40 x 1 9/64 Oval #4 Head
Price Set/4 \$ 0.65

Zenith Carburetor Float

This is an all brass float for the Zenith carburetor.



A9550 28-31 Price Ea. \$ 22.50

Tillotson Carburetor Float

This is a brass float for the Tillotson carburetor.

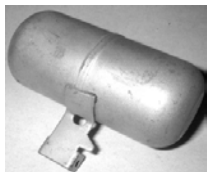

A9550T 28-31 Price Ea. \$ 16.35

Carburetor Float Hinge Bracket

This brass bracket holds the float in place. Includes two drive-in rivets.



A9554 28-31 Price Set \$ 3.00

Carburetor Float Pin



A9558Z 28-31 Zenith Price Ea. \$ 0.45

A9558T 28-31 Tillotson Price Ea. \$ 0.45

Carburetor Strainer

This gas strainer is available in either brass or cadmium plate for the Zenith carburetor.



A9559B 28-30 Brass Price Ea. \$ 6.15

A9559C 30-31 Cadmium Price Ea. \$ 5.75

Carburetor Float Valve / Gross Jet Style

Replaces the original needle and seat. This uses two balls to shut off the gas flow.



A9564GJZ 28-31 Zenith Price Ea. \$ 10.95

A9564GJT 28-31 Tillotson Price Ea. \$ 10.95

B9564Z "B" Carb Zenith Price Ea. \$ 14.25

Zenith Jet Gasket

An additional gasket may be needed for adjusting the level of gas in the bowl.



A9564G Zenith Only Price Ea. \$ 0.20

Tillotson Carburetor Inlet Needle & Seat

Brass Seat, Stainless Needle and Fiber Gasket.



A9533T 28-34 Price Set \$ 9.25

CARBURETOR

Mike's "A" FORD-ABLE Parts

Carburetor Driver - Zenith or Tillotson

This is the adjustment needle driver for the carburetor.



A9570C 28-31 Cadmium
 Price Ea. \$ 8.50

Carburetor Jet Tap

This special tap is to clean the jets on the Zenith carburetor. This is a 5mm 75 Pitch tap.



T9574 28-31 Price Ea. \$ 6.25

Carburetor Compensator Jet



A9575 28-31 Price Ea. \$ 1.95

Carburetor Passage Plugs - Zenith

You will need a new set of these when you clean the internal channels in a Zenith carburetor. Drill out old ones, then peen new ones in place.



A9576 28-31 Price Set / 4 \$ 1.65

Carburetor Idle Mixture Screws - Zenith

Screw with cap and stainless spring. The '28- Mid 1930 are brass with large heads, '30-'31 are cadmium.

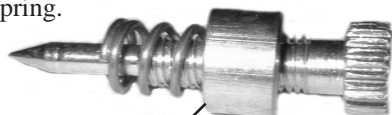

A9577AMB 28-29 Brass A9577BMB
 Price Set/3 \$ 3.45
 A9577BMB 30-31 Cadmium
 Price Set/3 \$ 2.95



A9577T 28-31 Tillotson - Brass
 Price Set/3 \$ 2.90

Carburetor Throttle Shaft & Lever - Zenith

If your shaft and lever are worn, replace it with a new oversized one. Standard size is .281 diameter, oversize is .294.



A9581 28-31 Diameter Standard 9/32"
 Price Ea. \$ 13.35
 A9581OS 28-31 Diameter Over Size 19/64"
 Price Ea. \$ 16.25

Carburetor Throttle Shaft Bushings - Zenith

Carburetor housings get worn where the throttle shaft goes through. These knurled bushings bring the holes back to size. Some machine work to be done.



A9581BU 28-31 Price Pair \$ 2.30

Carburetor Throttle Shaft End Plug

Some of the carburetors, the throttle shaft was drilled completely across the throat of the carburetor and a 9/32" brass end plug was taped into the housing to keep dirt from the shaft.



A9581P 28-31 Price Ea. \$ 1.30

Carburetor Idle Stop Screw

This fine-threaded screw goes on the throttle lever to set the idle. This is a 8-36 x 5/8 Screw.



A9582S 28-31 Price Ea. \$ 0.55

Carburetor Throttle Plate - Zenith

This is a heavy brass plate for the Zenith carburetor.



A9585 28-31 Price Ea. \$ 4.85

CARBURETOR

Mike's "A" FORD-ABLE Parts

Carburetor Double Venturi

Apply heat to free the venturi if it is stuck.



A9586A 1928 - Sept. 28 Price Ea. \$ 33.00

Carburetor Venturi

This is the single venturi used on the Zenith carburetor.



A9586 September '28 - End of '31
Price Ea. \$ 5.50

Carburetor Drain Plug - Zenith & Tillotson

The drain plugs are brass for 1928 - March 1930, cadmium for 1930-1931.



A9590B 28-29 Brass Price Ea. \$ 1.30
A9590C 30-31 Cadmium Price Ea. \$ 1.25

Carburetor Fuel Level Gauge

Remove the guesswork on your Zenith carburetor. This set shows the gas level in the carburetor bowl, so you can adjust float level. Gas should be 5/8" below gasket.



A9599 28-31
Price Kit \$ 5.00

"B" Zenith Carburetor Fuel Level Gauge

This fuel level gauge has been designed for the Zenith Carburetor. Used on the 1928 - 1934 4 Cylinder. The kit consists of a Tube, fuel sight, a Tube Assembly 3/16" U, and also a spare O ring.



B9599 28-34 Price Kit \$ 9.00

Tillotson Carburetor Choke Shaft

This does not work on the cast iron Zenith carburetors.



A9610 28-31 Price Ea. \$ 4.65

Tillotson Carburetor Choke Plate

This brass plate does not work on the cast iron Zenith carburetors.

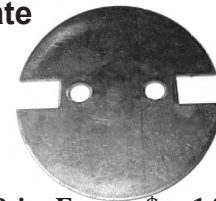

A9611 28-31 Price Ea. \$ 1.95

Tillotson Carburetor Throttle Shaft

The Tillotson throttle shaft comes with lever attached. Does not work on the cast iron Zenith carburetors.



A9629 28-31 Price Ea. \$ 11.95

Tillotson Carburetor Throttle Plate

This brass throttle plate will not work on Zenith cast iron carburetors.



A9631 28-31 Price Ea. \$ 1.35

Carburetor Air Maze with Original Metal Screen Filter

This acts as an air cleaner and a flame arrester in case of backfire. Fits Zenith Carbs. We are also now stocking an air maze that has been adapted to fit a Tillotson.



A9600Z 28-31 Zenith Price Set \$ 24.95

A9600T 28-31 Tillotson Price Set \$ 29.95

Carburetor Air Maze with Paper Filter

Same as the A9600 but with modern paper to clean air impurities instead of just a metal screen. For Zenith or Tillotson.

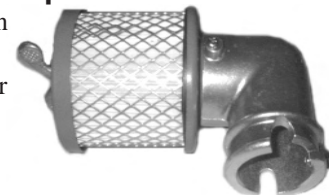

A9600ACCZ 28-31 Zenith Price Set \$ 34.95

A9600ACCT 28-31 Tillotson Price Set \$ 39.95

Carburetor Air Filter - Replacement Paper Filter

You can simply remove the metal screen from the air maze and fit this on. No modifications needed. For use on the Zenith or Tillotson Air Maze.



A9600F 28-31 Price Ea. \$ 12.50

CARBURETOR

CARBURETOR CONTROLS

Choke Rod Set

This choke rod has a chrome plated knob and comes complete with sleeve and spring.



A9700B	28-29	26"	Price Set/3	\$ 9.95
A9700C	30-31	28 1/2"	Price Set/3	\$ 9.95

Choke Rod Sleeve

This sleeve holds the choke rod on at the carburetor. Cadmium.



A9705	28-31	Price Ea.	\$ 2.10
--------------	--------------	------------------	----------------

Choke Rod Spring

Fits all models.

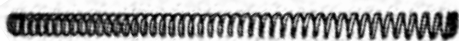

A9709	28-31	Price Ea.	\$ 0.60
--------------	--------------	------------------	----------------

Choke Rod Lower Grommet

This is the grommet that fits on the firewall



A9715	28-31	Price Ea.	\$ 0.60
--------------	--------------	------------------	----------------

Choke Rod Upper Grommet

This is the grommet that fits on the dash. TIP: An occasional drop of oil on the choke rod keeps this from being pulled out.



A9717	28-31	Price Ea.	\$ 0.70
--------------	--------------	------------------	----------------

Choke Rod Grommet Set

If you want your "A" exactly like they were made, you'll want this 4 piece set of both grommets plus a leather washer and a steel washer that fit on the engine side of the firewall.

Paint Washer black.



A9715/17	28-31	Price Set/4	\$ 1.65
-----------------	--------------	--------------------	----------------

Accelerator Cap (Authentic)

This cadmium plated accelerator cap is made just like the original.



A9725OR	28-31	Price Ea.	\$ 2.80
----------------	--------------	------------------	----------------

Footrest & Accelerator Cap Rubber Pad

This rubber pad fits the accelerator cap.



A9765P	28-31	Price Ea.	\$ 1.25
---------------	--------------	------------------	----------------

Fulton Accelerator Pedal

This is an exact copy of a popular accessory used with this accelerator by bolting onto the floorboard. Chrome pedal with rubber insert.



A9735F	28-31	Price Ea.	\$ 27.75
---------------	--------------	------------------	-----------------

Accelerator Spring

This is the spring that returns the gas pedal to the idle position. Mounts on the accelerator shaft and bracket.



A9737	April '30-31	Price Ea.	\$ 2.25
--------------	---------------------	------------------	----------------

Accelerator Spring

This is the straight cylindrical spring used in 1928 to early 1930. Includes pin.



A9737AR	28 - Early 30	Price Set	\$ 2.95
----------------	----------------------	------------------	----------------

Control Rod Sleeve

By cutting off 1/4" from your Spark Rod, and install the sleeve. This allows you to set your spark adjustment if necessary.



A9758	28-31	Price Ea.	\$ 8.50
--------------	--------------	------------------	----------------

CARBURETOR CONTROLS

Mike's "A" FORD-ABLE Parts

Control Rods

These cadmium plated rods have spring loaded ends.



A9742	28-31	Throttle 5 3/4"	Price Ea.	\$ 6.20
A9747	28-31	Accelerator 10 1/2"	Price Ea.	\$ 9.35
A9757	28-31	Spark 17"	Price Ea.	\$ 10.95
A9740S	28/31	Set of Three	Price Set/3	\$ 23.00

See Judging Standards for correct sizes - Page 1-7.

Accelerator Footrest

This footrest is cadmium plated with a rubber insert like the original.

Base A9770 and Screws A9770MB are not included.



A9765R	28-31	Price Ea.	\$ 3.95
--------	-------	-----------	---------

Accelerator Footrest Base

This is a cast aluminum base with screw holes.



A9770	28-34	Price Ea.	\$ 3.25
-------	-------	-----------	---------

Accelerator Footrest Base Screws

Use these to attach the footrest base (A9770) to the floorboard.



A9770MB	28-31	3 #6 x 3/4" oval wood screws	Price Set/3	\$ 0.40
---------	-------	------------------------------	-------------	---------

**See Page Gen. 14 for
Pedal Pads.**

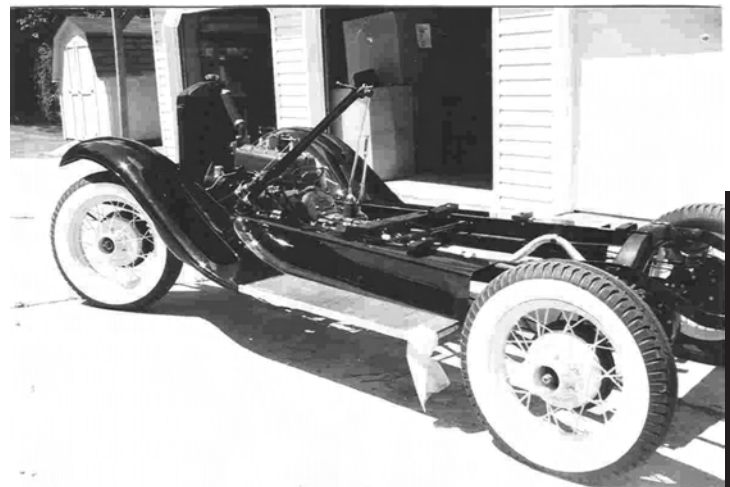
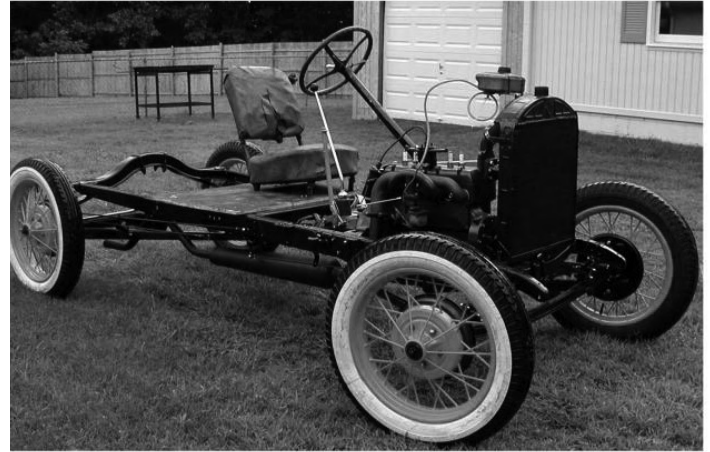

CARBURETOR CONTROLS

GENERATOR & ALTERNATOR

Specifications:

Type:	Two pole
Voltage regulation:	Fixed control
Brushes:	three (one adjustable)
Armature bearings:	1929-mid 1930 ball front and rear; after mid 1930, ball front, bushing rear
Armature speed:	1-1/2" of engine speed
Armature length:	7-9/16" (1928 to April 1930) - uses 1-5/32" wide pulley; 7-21/32" (after April 1930) - uses 7/8" wide pulley
Max. Normal charging rate:	12 amps @ armature 1600 rpm (car speed 25 m.p.h.)
Cutout closes:	about 9 m.p.h.
Cutout opens:	about 8 m.p.h.
Contact gap:	.015" to .020"
Core gap:	.010 (contacts closed)
Brush spring tension:	25 to 40 oz. each
Field coils:	100 turns of #17 copper wire
Armature:	14 coils, each with 6 turns of #17 copper wire
Commutator:	28 copper segments
Field current draw:	6.3 amps at 7 volts, generator (motoring draws 5.75 amps at 7 volts)
Maximum current:	18 to 22 amps at 6 volts
Motoring freely:	5 amps at 6 volts
Field test:	5.2 amps at 6 volts

***** **MIKE'S TIPS** *****

It is a very simple operation to increase or decrease the generator rate. Remove the Cover Band and shift the third brush (drivers side) - to increase amps move the brush in the direction of the rotation - to decrease move in the opposite direction. If you plan on doing any night time driving, I suggest you increase to 10-12 amps to compensate for the headlight usage. To increase the charging rate on your generator for night driving, pull the third brush away from the engine, then check your amps, and correct as necessary.

Rebuilt Generator - 6 Volt

New field coils, bushings, bearings and brush Armature rewound and turned. Painted - ready to install. Fully guaranteed. Does not include Pulley (**Page Gen. 161**) or Cut-Out (**Page Gen. 163**).



Exchange Only

A10000EL	28-30	Long Nose - 7/8" Tapered Price Ea. \$ 105.00
A10000ES	30-31	Short Nose - 1/2" Tapered Price Ea. \$ 105.00
A10000CGC		Core - Exchange Price Ea. \$ 100.00

Outright Only

A10000LO	28-30	Long Nose - 7/8" Tapered Price Ea. \$ 210.00
A10000SO	30-31	Short Nose - 1/2" Tapered Price Ea. \$ 210.00

***** **MIKE'S TIPS** *****

The advantage of an alternator is that it continues to charge even at idle - this gives you bright lights and a working horn at night. Alternators will not let your battery overcharge. When fully charged you will have an amp reading of approx. 1 amp.

Alternators - (Needed for Quartz Lights)

If your generator doesn't give the amps you need, this is what you want. High output pulley and mounting brackets **A10001B** are included. Mounting bolt and tension brace are also included. A \$24.40 value. No Exchange Needed.

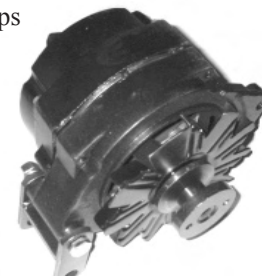

A10001AHD	28-31	6-volt - 60 Amp Price Ea. \$ 145.00
A10001A12	28-31	12-volt - 60 Amp - Negative Ground Price Ea. \$ 144.00

Alternator Bracket

This bracket is included when you purchase a new alternator.



A10001B	28-31	Bracket Price Ea. \$ 17.95
----------------	--------------	-----------------------------------

Mike's "A" FORD-ABLE Parts

GENERATOR / ALTERNATOR

A guideline to go by when converting from 6 Volt to 12 Volt electrical systems:

Battery - 12 Volt - Negative Ground (Not Stocked)

A10002A12 - 12 Volt Alternator - Negative Ground

A11081 - 12 Volt Starter Field Coils

A12000T - 12 Volt Coil (Not Stocked)

A12001 - 12 Volt Resister for Coil

A13007T - 12 Volt Head Light Bulb

A13308T - 12 Volt Parking, Dash, Cowl, Dome & Tail Light Bulb (Not Stocked)

A13465T - 12 Volt Stop Light Bulb (Not Stocked)

A13820B - Horn Resistor

A17585 - Electric Wiper Resistor (Not Stocked)

A10850C or CF Amp Meter for 60 Amp or 12 Volt

Power Inverter

Converts your 6 volt positive ground to 12 volt negative ground, to power radios, CB's or other 12 volt accessories. Works on positive ground systems only.



A10000CHD 7.5 AMP Price Ea. \$ 99.95

Generator Field Coils

Improve your weak generator with these good quality reproductions. 2 Pieces per Set.



A10000FC6 28-31 6 Volt Price Set/2 \$ 30.75

A10000FC12 28-34 12 Volt Price Set/2 \$ 32.75

Generator Armature

Armature is rewound and commutator turned for smooth finish.



A10005BO 28-30 7/8" tapered pulley end - Outright

Price Ea. \$ 84.95

A10005CO 30-31 1/2" tapered pulley end - Outright

Price Ea. \$ 84.95

A10005 Core Charge Price Ea. \$ 25.00

A10005BE 28-30 7/8" tapered pulley end - Exchange

Price Ea. \$ 66.00

A10005CE 30-31 1/2" tapered pulley end - Exchange

Price Ea. \$ 66.00

Generator External Hardware

This set includes the screws that hold the support bracket to the generator. The cut out and bolt for pulley. Also included is a screw and square nut for the band. 14 Pieces.



A10011S 1929 Price Set/16 \$ 9.25

A10012S 30-31 Price Set/16 \$ 5.60

Generator Brush Set

Set of three brushes for your A generator. Does not work on early '28.



A10043 28-31 Price Set/3 \$ 1.95

Generator Rebuild Kit

Comes complete except for armature and field coil. 84 Piece Set and Instructions.



A10020BS 28-31 Price Set/84 \$ 38.50

Generator Brush Holder Bushing

This bushing fits over the stud that the brush holder pivots on and slides inside the brush holder.



A10048 29-31 Price Ea. \$ 1.20

Generator Stop Pin Insulator

This slides onto the smaller stud on the 3rd plate brush plate assembly.



A10049 29-31 Price Ea. \$ 1.40

Generator Brush Holder

Brush secures to this holder. Zinc Plated.



A10051 29-31 Need 3 Price Ea. \$ 4.75

Generator Brush Spring

This is for the right hand spring for the 3rd Generator brush and Ground Brush.



A10057 29-31 Need 2 Price Ea. \$ 0.95

Mike's "A" FORD-ABLE Parts

Generator Main Brush Spring

This is for the Left Hand Main Spring.



A10068 29-31 Price Ea. \$ 1.15

Generator Third Brush Plate Assembly

This is the rotating plate to adjust the amp output.



A10072 29-31 Price Ea. \$ 5.10

Generator Third Brush Plate Retainer

This holds the brush plate (A10072) to the end plate.



A10075A 29-31 Need 2 Price Ea. \$ 3.25

Generator Stud Clip

This little clip secures the brush holder to the pivot stud.



A10076 29-31 Price Ea. \$ 0.45

Generator Front or Pulley End Bearing

For the early '28 powerhouse generator.



A10093AR 1928 - July '29 Price Ea. \$ 6.15

Generator Front or Pulley End Bearing

For the later '28 powerhouse generator through the end of production. This bearing goes in the pulley end.



A10094 28-31 Price Ea. \$ 4.65

Generator Rear End Plate Bearing

For late '28-'30 generators. This bearing goes in the rear of the generator.



A10095AR 28-30 Price Ea. \$ 5.50

Generator Front End Plate Bearing Screws

Used when installing A10095AR.

Stainless screw - rivet.

4 screw rivets and nuts.

You may need to cut rivets a little shorter.



A10096 29-30 Price Set/8 \$ 1.45

Generator Bearing Spacer

This spacer fits to the front of the bearing in the generator.



A10097 29-31 Price Ea. \$ 1.30

Generator Bearing Retainer Plate

This is riveted to the generator front plate (pulley end) to hold the bearing in place.



A10098 29-34 Price Ea. \$ 2.50

Generator Retaining Ring

This ring fits to the front of the spacer. Need 2.



A10099 29-31 Price Ea. \$ 1.00

Generator Terminal Wire

You'll need to solder the wire end of this to the head of the bolt that goes through the casing to the cut out.



A10102 29-30 Price Ea. \$ 1.60

A10102B 30-31 Price Ea. \$ 1.60

Generator Terminal Nut

2 10/32 x 7/16" hex nuts and l.w.s.



A10104B 28-30 Brass Price Pair \$ 1.35

A10104C 1931 Copper Price Pair \$ 1.55

Generator Post Washer

This fits over the bolt attached to the terminal wire inside the casing.

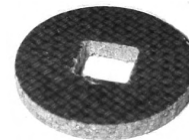

A10106 29-31 Price Ea. \$ 1.65

Mike's "A" FORD-ABLE Parts

GENERATOR / ALTERNATOR

Generator Terminal Post Components

Uses a modern terminal bushing and washer with original post.



A10104M 29-31 Price Set/9 \$ 5.30

Generator Ground Lead

This ground lead attaches to the generator main brush.



A10108 29-31 Price Ea. \$ 1.50

Generator Bearing Retainer Components

Retainer - Retainer Felt - Retainer washer 2 Retainer rings - Bearing spacer.



A10113A Felt Retainer Only Price Ea. \$ 1.30
A10113B 29-31 Price Set \$ 5.90

Generator Bearing Washer

This washer fits between the felt washer and the bearing.



A10114 29-31 Price Ea. \$ 1.30

Generator Rear End Plate Bushing

ID .626 O.D. .752 Length .965.

Replaces earlier style (A10095AR - Page 160) bearing. Installed April '30 till end.

Oil soaked for good wear.



A10128 30-32 Price Ea. \$ 0.95

Generator Rear End Plate Assembly

Plate includes bearing race - 2 brush holder studs, 2 brush holder stop pin studs and oil cover. All holes are drilled and tapped.

Used October 1928 - April 1930 - with ball bearing end plate



A10129BR 28-30 Price Ea. \$ 25.00

Generator Pulley

Cast iron pulley for the generator.



A10130B Oct. '28 till April '30 - Long Nose - 7/8" Price Ea. \$ 19.95

A10130A April '30 - till End - Short Nose - 1/2" Price Ea. \$ 24.45

Generator Pulley Adapter

If you have the earlier long nose generator and cannot find the correct pulley, you can now use the more common short nose pulley with this adapter.



T10144R 28-31 Price Ea. \$ 2.45

Alternator Pulley

This high output pulley has a smaller diameter than standard. Fits any alternator with a .670 shaft size.

This gives a 20% faster R.P.M, which allows a charging rate at a lower engine R.P.M.



A10131A 28-31 Price Set \$ 22.50

Generator Commutator Oil Cup

The '30-'31 A's used this cadmium oil cup on the end plate of the generators.



A10141 30-31 Price Ea. \$ 1.25

Generator Band

This is a good reproduction of the original band that covers the slots for getting to the brushes. Mounting hardware included.



A10142OR 28-31 Price Ea. \$ 3.95

Generator Cooler and Band

Extend the life of your generator by keeping your brushes and armature from overheating.



A10142 28-31 Price Ea. \$ 18.25

Generator & Starter Band Screw & Nuts

Round headed screw and square nut to hold either starter or generator bands on. 10/32 x 1 1/4" Screws.



A10142MB 28-31 Price Set/2 \$ 0.40

Mike's "A" FORD-ABLE Parts

Generator Pulley Bolts

Thin-headed bolts with lock washers. Two sizes were used so check yours before ordering.



A10143A	7/8" Taper - October '28 - April '30 1/4"-28 x 7/16" Bolt Price Set \$ 0.80
A10143B	1/2" Taper - April '30 till end 5/16"-24 x 1/2" Bolt Price Set \$ 0.90

Generator Wick/Spring

This fits on the rear end plate of the generator.



A10145	30-31	Price Set/2 \$ 1.90
--------	-------	---------------------

Generator Bearing Plug

This fits on the rear end plate of the generator.



A10149	30-31	Price Ea. \$ 0.95
--------	-------	-------------------

Pivot Bolt and Nut (Generator)

This is the bolt and nut that holds the generator on.

1/2-20 x 2 3/4 Bolt Lockwasher & Nut.



A10151	28-31	Price Set/3 \$ 1.50
--------	-------	---------------------

Pivot Bolt and Nut (Alternator)

Longer than the above, this bolt and nut is what you'll need when you add an alternator, due to the thick brackets.



A10151B	28-31	Price Set/3 \$ 1.50
---------	-------	---------------------

Generator / Alternator Tension Brace

This useful accessory holds the generator or the alternator tight against the fan belt. Free with purchase of Alternator.



A10152	28-31	Price Set/5 \$ 4.95
--------	-------	---------------------

Alternator Bracket - 6 or 12 Volt

This bracket comes with the alternator. Just in case you need a spare. See Page Gen. 158 for alternator.



A10001B	28-31	Price Ea. \$ 17.95
---------	-------	--------------------

Generator Cut-out Diode

This solid state diode improves the old cutout. Instructions included.

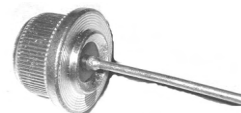

A10155D10	28-31	Price Ea. \$ 3.15
-----------	-------	-------------------

Generator Bearing Felt

This goes between the bearing washer and the bearing felt retainer on the front of the generator.

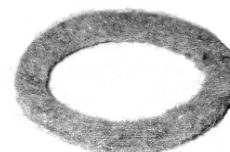

A10160	29-31	Price Ea. \$ 1.10
--------	-------	-------------------

Generator Through Bolt

These Bolts keep the ends in Place. 2 Needed per Generator. 1/4-20 x 6" Bolts & l/w's.



A10166	29-31	Price Ea. \$ 2.00
--------	-------	-------------------

Generator Field Insulator

This insulates the field coils in the generator.



A10193	29-31	Price Ea. \$ 1.00
--------	-------	-------------------

***** MIKE'S TIPS *****

If your cutout is not working properly, the ammeter will remain on the discharge position after the ignition switch is turned off. What you can do is tap the cover of the cut out, the points inside should release to allow the meter to return to zero. I suggest you replace with a new Diode type cutout. (A10505D).

Mike's "A" FORD-ABLE Parts

GENERATOR / ALTERNATOR

Generator Cut-Out (Semi-Conductor type) Positive Ground - 6 or 12 Volt

This semiconductor (state of the art) unit modernizes and replaces the original relay type of past years. It is identical to original exterior appearance and dimensions and is plated in cadmium as original. Also includes authentic insulators and hardware.

It is designed to continuously handle the maximum 20 ampere output of the original Ford DC third brush generator. It can be used on Model "A" and early V-8 positive ground systems. Comes complete with all electrical hardware and instructions for use.



THIS PRODUCT IS NONREFUNDABLE.

A10505D 28-31 Price Ea. \$ 48.95

Generator Cut-Out Mounting Screws

Set of two screws and lock washers to attach the cutout to the generator. 2 x 10/32 x 5/16.



A10505MB 29-31 Price Set/4 \$ 0.75

Starter or Generator Pole Screw

This is the screw that penetrates the generator casing to hold the heavy steel plates in place. Needed for Generator - 4 needed for Starter.

3/8" - 16 x 5/8".

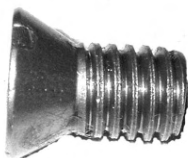

A11086 28-31 Price Ea. \$ 0.90

Generator Cut-Out Clip

This clip attaches to the side of the cut out and slips over the post of the generator. NOTE: Already on new cut outs.



A10550 28-31 Price Ea. \$ 0.60

Generator Cut-Out Insulators

Special fiber washers that fit where the bolts go through the cap on original cut outs. The thin one goes with A10550 connector - the thicker one has a special square to fit into the square hole in the cutout.



A10563 28-31 Price Pair \$ 1.25

Generator Cut-Out Screws

Set of two 10-32 x 1/2" thick headed hex screws with lock washers, that go through original cut out terminals.



A10564 28-31 Price Set/4 \$ 1.20

AMP Meters (Ford Script was not original)

This is the original style amp meter. You'll need the 30-30 if you have a high output generator or are running on a 12 Volt system. Nuts A10850N included.



A10850B	28-31	20-20	Price Ea.	\$ 8.00
A10850BF	20-20	Ford Script	Ea.	\$ 9.50
A10850C	28-31	30-30	Price Ea.	\$ 8.25
A10850CF	30-30	Ford Script	Ea.	\$ 9.75

AMP Meter Nut

This is an insulated nut to attach wires to the amp meter. Included with amp meter. 2 Used on amp meter and one used on original pop-outs.

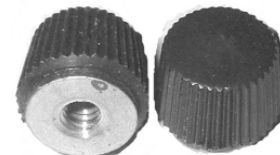

A10850N 28-31 Price Pair \$ 1.50

AMP Ford Script Plate (Ford Script was not original)

This face plate will fit on either the original or reproduction amp meters.

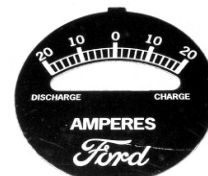

A10850P 28-31 Price Ea. \$ 1.95

AMP Meter Ring

This is a chrome plated trim ring for the amp meter. Included with amp meter.



A10864 28-31 Price Ea. \$ 3.25

STARTER

Specifications:

Type of drive: Bendix (except early 1928)
 Terminal grounded: Positive
 Rotation: Counterclockwise (viewed from commutator end)

Armature: 21 segments
 Brush spring tension: 35 to 40 oz.

Starter data:	Torque	RPM	Volts	Amps
Normal:	3	1500	5	175
Running Free:		4000	6	50
Locked:	15	0	3.2	550
Test Data:	4	1000	4.85	225
	8	540	4.15	360
	12	220	3.60	475

Rebuilt Starters - 6 Volt

Please remove your bendix if you are returning a core!

Includes rewind armature & field coils.
 Fully guaranteed. Does not include the Starter Switch A11450 (Page Gen. 166) and Bendix A11350 (Page Gen. 166).

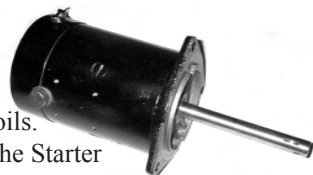

A11002E	28-31	Exchange	Price Ea.	\$ 120.00
A11002C		Core	Price Ea.	\$ 100.00
A11002	28-31	Outright	Price Ea.	\$ 220.00

Starter Armature Assembly

Armature is rewind and commutator is turned for a smooth finish.



A11005DE	28-31	Exchange	Price Ea.	\$ 71.00
A11005DC		Core	Price Ea.	\$ 15.00
A11005D	29-31	Outright	Price Ea.	\$ 86.00

***** MIKE'S TIPS *****

Do Not use a bolt longer than 1", as it will rub or lock up the flywheel

Starter Mount Set

Complete set of bolts and lock washers to mount the starter.



A11002MB	28-31	3 x 3/8" - 16 x 1" bolt & l.w.	Price Set/6	\$ 2.00
----------	-------	--------------------------------	-------------	---------

Starter Rebuild Kit

For the DIYer. Complete with all brushes, springs, etc., that you will need.
 Instructions Included.

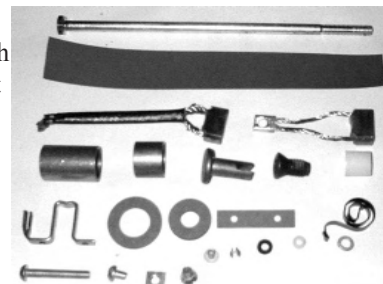

A11025S	28-31	Price Set/56	\$ 31.00
---------	-------	--------------	----------

Starter Armature Thrust Washer

This is a fiber washer that fits on the front end of the shaft, next to the commutator.

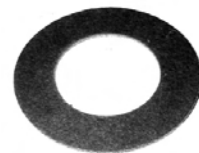

A11036	28-31	Price Ea.	\$ 0.40
--------	-------	-----------	---------

Starter Front End Bushing

This bushing fits on the starter drive end, brush end.



ID .640, OD .753 - Length .592

A11052	28-31	3/4" OD	Price Ea.	\$ 1.45
--------	-------	---------	-----------	---------

Starter Brush Set

2 Insulated Brushes and 2 ground Brushes.

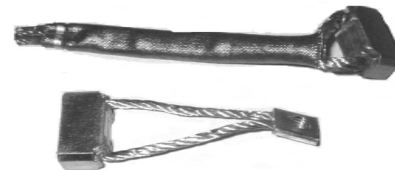

A11054S	28-31	Price Set/4	\$ 4.10
---------	-------	-------------	---------

Starter Brush Spring

This spring keeps the brush over the armature.



A11059	28-31	4 needed	Price Ea.	\$ 0.50
--------	-------	----------	-----------	---------

Starter Brush Holder

This holds the spring and brush in place



A11061	28-31	4 needed	Price Ea.	\$ 1.00
--------	-------	----------	-----------	---------

Mike's "A" FORD-ABLE Parts

Starter Brush Holder Insulator

This plate insulates the brush from the end plate.



A11062 28-31 Price Pair \$ 0.75

Starter Brush Holder Rivets

This 16 piece set includes the 4 short rivets for the ground brush holders, 4 long rivets, 4 fiber insulating spacers for the rivets, and 4 fiber insulators for under the rivet head.



A11063 28-31 Price Set/16 \$ 3.60

Starter Rivet Insulating Washer

You'll need four of these between the brush holder and the brush holder insulator.



A11072 28-31 Price Ea. \$ 0.35

Starter Brush Holder Rivet Insulator

These bakelite insulators go between the rivets and the brush holder insulator.



A11073 28-31 Price Ea. \$ 0.30

Starter Field Coils

Set of two high quality starter field units. 100 % Copper Wire and fabric wrapped for insulation.



A11082/85 28-31 6 Volts Price Set/2 \$ 31.00
A11082/8512 28-31 12 Volts Price Set/2 \$ 35.75

Pole Screw (For Starter and Generator)

This screw goes through the starter casing to hold the steel plates that hold the starter fields in place. 2 for Generator and 4 for Starter

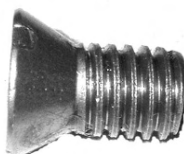

A11086 28-31 3/8" - 16 x 5/8" Price Ea. \$ 0.90

Starter Field Coil Insulator

This insulation wraps around the field coils to prevent shorts. Goes around brushes.



A11087 28-31 Price Ea. \$ 1.50

Starter End To End Bolt

You'll need two of these bolts with lock washer and nut. They go from end to end to hold the starter together.



2 x 1/4" - 20 x 6 3/4" & l.w.& nut
A11091 28-31 Price Ea. \$ 2.10

Starter Contact Button

This is the contact button at the top of the starter that the starter switch makes connection with. A11106, A11107 & A11108 should also be purchased.



A11102 28-31 Price Ea. \$ 3.85

Starter Field Terminal Insulator

The contact button sits on this insulator on the outside of the starter.



A11106 28-31 Need 2 Price Ea. \$ 0.75

Starter Field Terminal Bushing

The contact button sits inside this bushing through the starter casing.



A11107 28-31 Need 1 Price Ea. \$ 1.25

Starter Field Insulator

This insulator sits on the starter casing where the contact button enters.

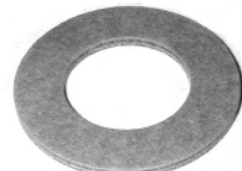

A11108 28-31 Need 1 Price Ea. \$ 0.75

Starter Band

This reproduction covers the slots for adjusting the brushes.

A11125MB comes with this.

1 x 10-32 x 1 1/4 screw and square nut.

A11125 28-31 Price Ea. \$ 3.95



Starter & Generator Band Screws

Spare screws & nuts for your A11125.

1 x 10-32 x 1 1/4 screw and square nut.

A11125MB Price Set \$ 0.40



STARTER

Mike's "A" FORD-ABLE Parts

Starter Shim (Paper Gasket)

These shims are used between the starter and the bell housing to adjust the gear meshing.



A11130SH 28-31

Price Ea. \$ 0.50

Starter Rear Armature Washer

This fits at the rear of the armature as a thrust washer.



A11132 28-31

Price Ea. \$ 0.50

Starter End Plate Bushing

This bushing goes on the rear end plate of the starter, opposite of the brush end. 1.155" Wide.



A11135A 28-29 .688 OD - .627 ID

Price Ea. \$ 0.95

A11135B 29-31 .753 OD - .627 ID

Price Ea. \$ 1.05

Bendix - Starter Drive

This is a complete starter drive. Don't forget to order the A11384 Key.



A11350 28-31

Price Set \$ 27.95

Starter Bendix Shaft # 6 Woodruff Key

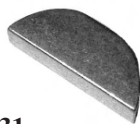

A11384 28-31

Price Ea. \$ 0.40

Bendix - Starter Drive Spring

These are the later 3/8" bolt eyelet. Early 5/16" no longer available.



A11375 28-31

Price Ea. \$ 6.75

Bendix Drive

This modern style starter device is more reliable, and perfect for 6 or 12 Volt applications. See T11350 for installation Tool.



A11350M

Price Ea. \$ 29.95

Modern Bendix Drive Installation Tool

A handy unit to help with the installation of the modern drive. Instructions Included.



T11350

28-31

Price Ea. \$ 17.50

Starter Drive Bolts/Washers

Thin headed bolts with special washers to hold the drive on the shaft and to hold the drive spring in place. Ford used two sizes so measure yours carefully.



A11382S 28-31 2 x 3/8"-24 & tab washer

Price Set/4 \$ 3.35

A11382SE 28-31 2 x 5/16"-24 & tab washer

Price Set/4 \$ 3.35

Starter Bendix Spring Bolt Washers



A11379A 2 - 5/16" Tabbed Washers

Price Pair \$ 0.85

A11379B 2 - 3/8" Tabbed Washers

Price Pair \$ 0.50

Starter Drive Spring Clips

Made and heat treated to original Ford specs. These are designed to stabilize the starter spring and help prevent bending and breaking of the starter spring screws. These are only made to use with the 5/16 size bolts, as explained in the Ford Service Bulletins.



A11383 28-31

Price Pair \$ 4.95

Starter Switch

Cadmium plated exact reproduction of the Ford original with copper terminal nut.



A11450 28-31

Price Ea. \$ 15.95

Starter Switch Gasket

This gasket fits between the starter switch and the starter.



A11450G 1928 - Early 1930

Price Ea. \$ 0.95

STARTER

Mike's "A" FORD-ABLE Parts

Starter Switch Bolts

Set of four each screws and lock washers to attach the starter switch.



A11450MB 28-31 4 x 10/32 x 5/16 & l.w.s
Price Set/8 \$ 0.75

Starter Switch Nut

This is the thin 5/8" nut for the starter switch Terminal. Includes Two nuts and one star washer.



2 x 3/8 - 16 x 5/8" wide

A11451N 28-30 Copper Price Set \$ 1.95
A11451NB Late 30 - 31 Brass Price Set \$ 1.45
A11451NS Feb. '31 - End Steel Price Set \$ 1.55

Safety Fuse Mount Set

If you've added a safety fuse, you'll need two of these longer screws with lock washers.



A11450SFMB 28-34 2 x 10/32" x 1/2" screw & l.w.
Price Set/4 \$ 0.50

Safety Fuses

Fuse for your safety fuse unit. Keep an extra on hand. Sold in 5's.



A11450FU 28-34 30 amps
Price Set/5 \$ 1.50

Safety Fuse

This safety accessory fits easily on the starter switch using the same holes.

Provides 30 amp protection.

Order A11450SFMB Screws.

Don't forget extra 30 Amp Fuses - A11450FU.

A11450SF 28-34
Price Ea. \$ 10.45

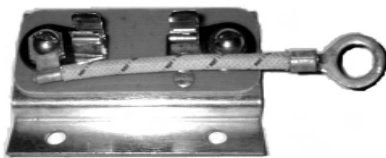

Sparky Start

This handy gadget attaches to your starter using the same mounting holes as your starter switch. When you retard your spark lever on the steering column, it automatically engages the starter switch to start the car. The starter button on the floor is still usable.



A11460 28-31 Price Set \$ 39.95

Hand Starter

This accessory mounts to your steering column and allows you to apply the starter button with a rod. You can still use your foot activated rod with this unit. It makes starting on a hill very easy.



A11470F 28-31 Price Set \$ 64.95

Starter Rod

This is a cadmium plated rod that screws into the starter switch. Order A11471P Cover.



A11470 28-31 Price Ea. \$ 1.95

Starter Rod Cover

This pad fits over the flat head of the starter rod so your foot won't slip off. Not originally used.



A11471P 28-31 Price Ea. \$ 1.25

Starter Rod Grommet

This original style grommet is made from hard rubber, has a resemblance to the original bakelite. No metal cover is used with this. Used from 1928 - August 1930.



A11480AR 28-30 Price Ea. \$ 4.80

Starter Rod Grommet & Cover

This style grommet and cover fits on your firewall and will have a D-nut on each side of the rod hole.

Used through 8/30.

A11480 28-30 Grommet Price Ea. \$ 1.50



A11481 28-30 Grommet Cover Price Ea. \$ 1.65

STARTER

Starter Rod Grommet & Cover

This style grommet and cover replaced A11480 in 9/30 through to the end of production. It used three rivets to mount. See A11481BMB.



A11480A 30-31 Grommet
Price Ea. \$ 0.75



A11481B 30-31 Grommet Cover
Price Ea. \$ 2.75

Starter Rod Grommet

This style grommet was used for about 6 months in 1930.

If your firewall has a single hole about 7/8" in diameter. No cover was used.



A11480C 1930 Price Ea. \$ 0.95

Starter Rod Cover Mount Screws

Use this pair of machine screws with lock washers to attach the starter rod cover (A11480/81).

2 x 12/24 x 1/2" Screws & lockwashers.



A11481MB 28-30 Price Set/4 \$ 0.50

Starter Rod Cover Mount Rivets

This set of three tubular rivets is used to attach the later starter rod cover (A11481B). Paint firewall color. Use Rivet tool RA2022 on Page Gen. 28.



A11481BMB 30-31 3 x 9/64" x 1/4" oval head
Price Set/3 \$ 0.60

SEE PAGE GEN. 156 FOR ACCELERATOR PARTS.

Do you like
the sound of
FREE
Shipping??

Order online
and get a 5%
Discount -
this could
cover your
shipping
costs!!

STARTER

IGNITION SWITCH

Ignition Switch On Off Plate

Refurbish your dash with this on-off plate. Reverse is plain black if you prefer that.



A11556 28-31
 Price Ea. \$ 1.25

Ignition Switch Plate Ring

This chrome ring holds the on-off plate in place.



A11557A 28-31
 Price Ea. \$ 2.60

Ignition Switch Data Plate

Make your original switch cable look factory fresh. For electralock cable.



A11557EL July '28 - Till June '30
 Price Ea. \$ 1.95



Make your original switch cable look factory fresh. For Briggs Stratton cable.



A11557BG June '30 - Sept. '30
 Price Ea. \$ 1.95

Ignition Switch Popout Rear Cup

This cup covers the back of the original Popout switch heads.



A11570 28-31
 Price Ea. \$ 5.90

Ignition Switch Popout Key Hole Cap

This nickel cap goes where the key goes into the switch assembly on the original Popout switches.



A11571AR 28-29 Price Ea. \$ 5.75



A11571BR 30-31 Price Ea. \$ 6.00

Ignition Switch Popout Key Hole Cap Bezel

This nickel bezel holds the key hole cap in place on the original Popout switch.



A11572AR 28-29 Price Ea. \$ 4.50

A11572BR 30-31 Price Ea. \$ 4.25

Electronic Ignition

This unit is easy to install, and undetectable after installation. Comes with all hardware, new coil and full instructions.

Will not work with original Popouts. See Page Gen. 174 for centrifugal Style.



A11574E6V 28-31 6 Volt Price Kit \$ 164.00

A11574E12V 28-31 12 Volt Price Kit \$ 164.00

For more Modern Distributors - See Page 173

Ignition Cables

These cables are for the electralock assembly. First style was used in '28-'29, second (a little longer) was used in early '30.



A11575RK1 28-29
 Price Ea. \$ 27.50



A11575RK2 1930
 Price Ea. \$ 27.50

Ignition Cables

This style was used for the '30-'31's with the round speedometers.



A11575RK3 30-31 Price Ea. \$ 18.95

IGNITION SWITCH

Mike's "A" FORD-ABLE Parts

Ignition Switch Assembly

This setup looks like the original Popout style cable but it uses the replacement style on-off switch. Now with a Top Quality Switch.

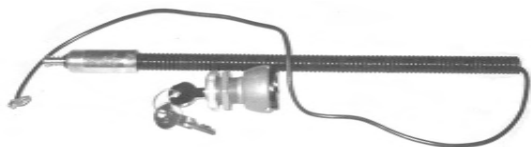

A11575ER 28-31 Price Set \$ 34.95

Ignition Switch Popout Mounting Set

Complete set to mount the Popout switch. Three screws for the head, one grommet for where the cable goes into the terminal box plus one wire nut.



A11575MB 28-31 Price Set/5 \$ 1.75

Ignition Cable Clamp

This clamp mounts on the head to hold the distributor cable. Clamps onto the #8 Head Stud - 3 11/16.



A11575CL March '29 - till End Price Ea. \$ 2.40

Ignition Switch Pop-Out Cable Clamp

The clamp located on the cylinder head stud to hold the Popout cable in place. Clamp only. Located on #8 cylinder head stud. Used on the 4 1/16" ignition stud.

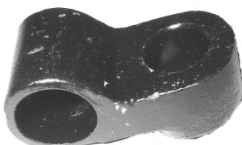

A11575CLA 28-29 Price Ea. \$ 7.75

Ignition Cable Only

The cable can also be used as an emergency jumper wire. This is the cable Only - use the A11575SW1 or A11575EM Switch.



A11575J 28-31 Price Each \$ 10.75

Ignition Reproduction Pop-Out & Keys

Very good on-off switch. Looks and mounts just like the original. Show Quality, but does not Pop Out.



A11575EM 28-31 Price Set \$ 52.75
A11575ERM 28-31 w/cable Price Set \$ 62.90

Ignition Switch

If part of your assembly is still good, you may want to replace only the bad. Excellent quality.



A11575SW1 Price Ea. \$ 16.95

Popout Switch Screws

If the screws and washers are needed - otherwise purchase A11575MB.



A11579 Price Set / 6 \$ 0.50

Ignition Cable Support & Terminal Box Grommet

This grommet holds the switch cable in the terminal box. Also see Page Gen. 197.



A14450GR 28-31 Price Ea. \$ 1.25

Ignition Emergency Jumper Cable

In an emergency, this can bypass some starter problems. Screw one end into the distributor, remove the red wire from the coil and clip jumper cable to that coil terminal where the red was attached. You will have to unhook the jumper wire from the coil, as the key will not stop the engine.



A11575EJ 28-31 Price Ea. \$ 18.50

SEE THE ACCESSORIES SECTION ON PAGE GEN. 18 FOR A SELECTION OF KEY FOBS

Ignition Key Blanks

These keys are the exact copies of the original Briggs & Stratton Ignition keys. Nickel Plated. Used on original locks only.



A11586C Ignitions from mid '30 - End of '31 - Round Speedo Price Ea. \$ 16.80

Door and Deck Lid Key - may not fit some crown style locks.
A11586D Late '28 - April '31 Price Ea. \$ 14.75

Mike's "A" FORD-ABLE Parts

Replacement Key Blank

A universal key blank for the original issue pop-out switches and handles. Special grooving permits dual usage. Round head as an inexpensive spare. Not for Crown door Locks.



A46123U

Price Ea. \$ 3.35

Lighting Wire Harness

Harnesses for both one and two bulb headlights. The 1-bulb harness also has a cowl light wire.



- | | | | |
|--------|-------|---------------------|--------------------|
| A11646 | 28-31 | One bulb cowl light | Price Ea. \$ 37.75 |
| A11647 | 28-31 | Two bulb | Price Ea. \$ 39.50 |

Lighting Wire Harness with Turn Signals

If you are considering putting Turn Signals into your "A" this would be the harness to get.



- | | | | |
|---------|-------|---------------------|---------------------|
| A11646T | 28-31 | 1 Bulb with Cowl | Price Ea. \$ 115.00 |
| A11647T | 28-31 | 2 Bulb without Cowl | Price Ea. \$ 123.00 |

Light Switch Body

Best available. This mounts on the bottom of the steering column and the light wire slips inside to control the lights. We have not found any of these bodies to meet with our standards. If at all possible use an original.



A11655/67 28-31 Price Ea. \$ 17.00

Light Switch Body Lower Half

The correct round shaped bottom for the lower Half of your Light Switch Body. Will fit the A11655/67 Repro's and original bodies. Short body - 1 7/8" Long.



A11655B 1928 - April 1930 Price Ea. \$ 13.05

Long Body - 2 1/8" Long.

A11655C April 1930 thru 1937



Price Ea. \$ 13.05

Instrument Panel

This chrome plated dash panel is for the oval speedometer. Includes screws A11805MBO.

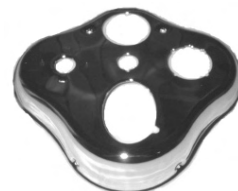

A11805AR 28-30

Price Ea. \$ 35.50

Instrument Panel

This chrome plated dash panel is for the round speedometer. Includes screws A11805MBR.



A11805E 30-31

Price Ea. \$ 32.50

Instrument Panel Screws

These chrome bolt sets are used to mount the dash panel.



Round Speedo has a larger head

A11805MBR 30-31 4 x 10/32 x 1/2" Screws Price Set/4 \$ 1.50

Oval Speedo
A11805MBO 28-30 4 x 10/32 x 1/2" Screws Price Set/4 \$ 1.50

Dash Rail Pad Set Only

These rubber discs fit between the dash rail and body. These pads are included with A11900C and A11950.

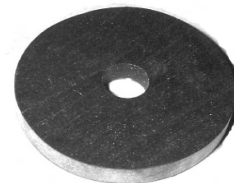

A11900P 28-31 Price Set/6 \$ 2.20

Belt Rail Screws & Rubber Washers

For Back of Dash Rail

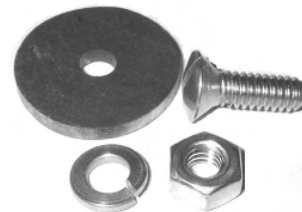

6 x 1/4-20 x 11/16" Oval head Screws, rubber washers, lws nuts.
A11900C 28-29 Chrome Price Set/24 \$ 2.50

5 x 1/4-20 x 11/16" oval head Screws & Rubber washers.
A11950 30-31 Chrome Price Set/10 \$ 2.50

IGNITION SWITCH

Mike's "A" FORD-ABLE Parts

Dash Belt Rail Side Screws

These two thin screws and lock washers are used to attach the lower corner of the dash rail to the door post.



12/24 x 19/32 Head Screws & l.w.s

A11952BR

28-31

Price Set/4 \$ 0.85

Dual Gauge Bracket (Water & Oil)

This gauge holder mounts around the steering column. Chrome Plated. Order the 1931 style for cars which have a column brace extending underneath the dash rail. An excellent copy of the old APCO gauge Bracket.



A6538AC

28-30

Price Ea. \$ 59.95

A6538BC

1931

Price Ea. \$ 59.95

Dual Gauge Holder

Holder to be used with both the oil and temp. gauges. Mounts under the dash. Chrome plated.



A6537C

1928 - Mid '30

Oval Speedo

Price Ea. \$ 43.50

A6537D

June 1930 - '31

Round Speedo

Price Ea. \$ 36.50

Oil Pressure Gauge Strap

This bracket is mounted using the two lower instrument panel screws. No drilling required. Black painted steel.



A6602OS

28-30

Oval Speedo

Price Ea. \$ 11.95



A6602RS

30-31

Round Speedo

Price Ea. \$ 11.95

IGNITION SWITCH

Order Online Now and Save 5%.

Visit our website for all your Model "A" needs.



www.mikes-afordable.com

DISTRIBUTOR

Specifications:

Rotor revolution direction:	counterclockwise
Point Gap:	.018" to .022"
Point spring tension:	16 to 18 oz.
Condenser capacity:	.20 to .25 MFD
Yellow wire ignition circuit:	12 gauge
All other wiring (except high tension circuit):	16 gauge
Cam shaft to bearing clearance:	.001" to .002"
Spark control manual advance:	20 degrees (28 degrees camshaft travel)
Rotor end cap to distributor body terminal:	.020"
Ignition circuit:	.62 amps at 6.2 volts - engine at 1500 rpm 4 amps at 6.2 volts (engine stopped)

The following new parts are required to complete a restoration of your Distributor and Ignition. This is only a guide - do not assume that this is all that is needed, all other parts need to be thoroughly checked and rebuilt if necessary. If rebuilding is something that you do not wish to do, new or rebuilt units are available at Mike's "A" Ford-able Parts.

1. Ignition coil - **A12000, A12000SC or CO**
2. Coil Brackets & Screws - **A12000CB**
3. Distributor Rebuild Kit (with original or modern points and condenser) - **A12127RK or RKM**
4. Spark Plug Connectors - **A12275A or B**
5. Spark Plugs - **A12405, RE or 3X**
6. Coil Wire - **A14302 or A14302M**
7. Terminal Box to Coil Wiring - **A14305**
8. Terminal Box to Dash Wiring - **A14401B**
9. Generator to Terminal Box Wiring - **A14406 or A14406A**
10. Terminal Box - **A14560**
11. Terminal Box Lid and Wing Nuts - **A14561A & A14561WN**

Distributor (New)

High quality new distributor for your A.

All Distributors include Cam, Rotor & Lower Shaft.

Totally Original as was first used on Model "A's".



A12100	28-31	Standard Price Ea.	\$ 121.50
---------------	--------------	---------------------------	------------------

New Distributor with Modern Upper Plate with Wireless Modern Lower Plate (eliminates Pigtail Problems).

Includes **A12150**.

A12100ML	28-31	Price Ea.	\$ 139.95
-----------------	--------------	------------------	------------------

Distributor (Rebuilt) Original

Excellent rebuilt distributors - **Includes Cam, Rotor & Lower Shaft.** Core charge is only refundable if returned within **30 days** of ship date and is in restorable condition.

Standard Rebuilt Distributor

A12131SE	28-31	Exchange Price Ea.	\$ 85.00
A12131SC		Refundable Core Charge	\$ 25.00
A12131SO	28-31	Outright Price Ea.	\$ 110.00

Rebuilt Distributor with Modern Upper Plate with Wireless Modern Lower Plate (eliminates Pigtail Problems).

Includes **A12150**.

A12131ME	28-31	Exchange Price Ea.	\$ 105.00
A12131MC		Refundable Core Charge	\$ 25.00
A12131MO	28-31	Outright Price Ea.	\$ 130.00

Distributor Housing Only

Completely new machined housing. Does not include any fittings or bushings.



A12100H	28-31	Price Ea.	\$ 50.00
----------------	--------------	------------------	-----------------

Distributor Puller

This will safely remove the distributor from the head without breaking the distributor casting.



T12130DP	28-31	Price Kit	\$ 31.50
-----------------	--------------	------------------	-----------------

DISTRIBUTOR

Distributor Heat Shield

Stainless steel shields clamp to head with head stud nuts to keep manifold heat from distributor condenser. Not an original item.

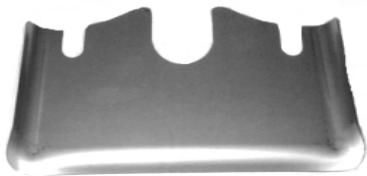

A12127 28-31 Chrome Price Ea. \$ 5.75

The Ultimate Distributor - The Zipper

The "Zipper" has all of the reliability of an electronic ignition but with the stock appearance. The "Zipper" is only 1/4" taller than stock distributor. Use your standard plug connectors to keep stock look. The "Zipper" works similar to the "B" distributor with weights and springs but has twice the advance and pertronix coil or points. Comes with 6 or 12 Volt Pertronix Coil.

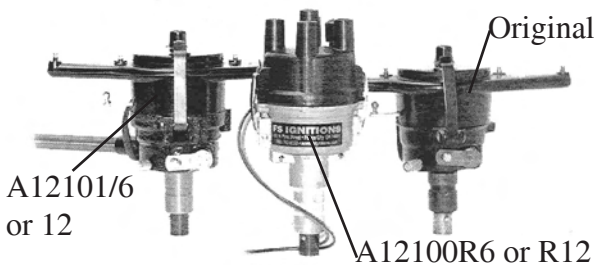

A12101/6 6 Volt Price Ea. \$ 430.00
A12101/12 12 Volt Price Ea. \$ 430.00

FS Centrifugal Modern Distributor (6 or 12 Volt)

Ignition system built right into the unit with automatic centrifugal advance. **6 Volt Positive Ground or 12 Volt Negative Ground.**

Dedicated line, no pop out needed. This is a complete modern style distributor that is a direct replacement for the stock A distributor. Coil Included.



A12100R6 28-31 6 Volt Price Ea. \$ 280.00
A12100R12 28-31 12 Volt Price Ea. \$ 275.00

Replacement Ignitor for Electronic Ignition

This is a replacement Ignitor for the **A12100R6** Electronic Ignition. **If you leave your key turned on for more than 30 seconds without the engine running you will need to replace the Ignitor.**



A12100R6MOD 6 Volt Price Ea. \$ 85.00

This is a replacement Ignitor for the **A12100R12** Electronic Ignition. Has a bypass so if the key is left on it will not pop the ignitor.

A12100R12MOD 12 Volt Price Ea. \$ 85.00

Wire Kit for FS Centrifugal Distributor

This is the wire connector that goes onto the FS Distributor **A12100R6** or **A12100R12**, and attaches to your plugs.



A12100W Price Set \$ 27.00

Distributor Body

High quality. Now available in Steel or Brass electrodes. The Brass is not original but will help avoid the corrosion problem that steel can cause. Ford Script not available.



A12105 28-31 Steel Price Ea. \$ 15.25
A12105B 28-31 Brass Price Ea. \$ 19.00

Distributor Body - Show Quality

These have the correct notches at the base. One for the index pin and the other for the spark control arm. Contacts are cadmium plated as original.



A12105S 28-31 Price Ea. \$ 22.75

Distributor Cap

Script caps no longer available. Bakelite like the original.

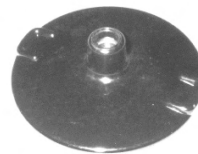

A12115 28-34 Price Ea. \$ 3.50

Clear Distributor Cap

A clear distributor cap is now available. Non Ford Script. Coming Soon!!



A12115C 28-31 Price Ea. \$

Modern Distributor Cap

Replace the original distributor cap with this modern cap with plug wires and wire boots. Fits like the original.

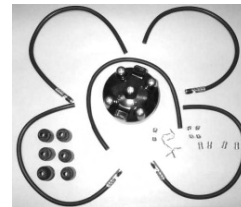

A12105M 28-34 Price Ea. \$ 23.95

Distributor Rotor

For the A distributor. Black bakelite as original.



A12200 28-31 Price Ea. \$ 3.35

Mike's "A" FORD-ABLE Parts

Distributor Body Kit

Enjoy the confidence of a moisture sealed system. This product is a must for the GO Car, An extremely well made body, cap and rotor. The body has been machined for the exact clearance for the rotor. Heavy duty posts on the body for the Modern Wire Kit. Especially designed for our A12405 or A12405RE Spark Plugs. A12450W 28-31 Price Set \$ 79.95



Distributor Spark Plug Connectors

These brass strips connect the spark plugs to the distributor.



A12275A 28-30 Straight Price Set/4 \$ 1.80



A12275B 30-31 Offset style. June 30 till end Price Set/4 \$ 1.80

Distributor Cam

An excellent cam that has been precisely machined. This is a "B" cam used on the "A". Creates a hotter spark; therefore longer plug life. Comes with lubricant.



A12210 28-31 Price Ea. \$ 10.75

Distributor Cam Wrench

Holds the cam in place, so you can tighten the cam screw, after you set the ignition timing.

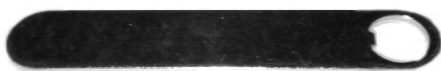

T12210CW 28-31 Price Ea. \$ 1.15

Z Distributor Cam Wrench

Quick Adjust Wrench. No distributor body or lead removal required. Cadmium plated with hang up hole.



T12210Z 28-31 Price Ea. \$ 2.40

Distributor Cam Lube

A special grease with silicone for your distributor cam. 7/8 Oz. Tube A12210L Any Price Ea. \$ 7.25



Distributor Cam Screw and Washer

This special screw with washer holds the cam to the shaft. Now has an oil hole, especially made for A12178M, but no problem being used on original upper shaft.



A12211/13 28-31 Price Set/2 \$ 1.25

Distributor Steel Cam Shaft Thrust Washer

Thin steel washer located at the top hole of the distributor. This item is included in kit A12127MB (Page Gen. 179). The collar on the upper shaft rides on this washer so that the collar does not wear the dist. housing.



A12180 28-31 Price Ea. \$ 0.30

Distributor Shaft Sleeve Fiber Washer

Located at the base of the distributor. This item is included in kit A12127MB (Page 179). Use this to take up end play.

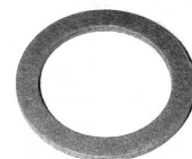

A12194 28-31 Price Ea. \$ 0.35

Distributor Upper Shaft Sleeve

This is pinned on the upper shaft to hold it in place at the base of the distributor.



A12195 28-31 Price Ea. \$ 1.50

Distributor Shaft Pin

This pin holds the sleeve on the upper shaft.



A12196 28-31 1 x 1/8" x 25/32 Roll Pin Price Ea. \$ 0.25

Distributor Upper Shaft With Oil Hole

Has a small hole drilled down the center about 1" from the top to shaft hole to create oil passage for upper bushing. Cam screw is included with a hole drilled through it. 3 Piece Set.



A12178M 28-31 Price Set/3 \$ 9.50

DISTRIBUTOR

Mike's "A" FORD-ABLE Parts

How to Time Your Model "A"

1. First place the spark rod in the fully retarded (up) position.
2. Next remove the timing pin (1/2 inch open end wrench) and place the non-threaded end in the hole the pin was removed from. The timing pin is located on the passenger side at the very front of the engine.
3. Now take your hand crank and slowly turn the engine over while holding inward pressure on the timing pin. When you feel the pin fall into a slight recess the #1 piston is at TDC (top dead center). This recess is very small and may be difficult to find. TDC can be verified by removing the #1 spark plug (closest to the fan) and looking at the piston inside the head. The piston should be at the top of the block. Replace timing pin.
4. Now remove the distributor cap and body as well as the rotor.
5. Loosen the cam screw and turn the cam so that the points are fully open. The points should now have a .020 gap. If the gap is too large or too small, adjust them at this time.
6. Turn the notch in the cam to roughly the passenger side Headlight. Place a cam wrench on the cam and turn it counterclockwise until the points just start to open, then tighten the cam screw while holding the cam from moving.
7. Replace the rotor and distributor cap and body.
8. You have just timed a Model "A" Ford.

HAVE AN "A" DAY!!

DISTRIBUTOR ASSEMBLY A12127MB - Part of Set

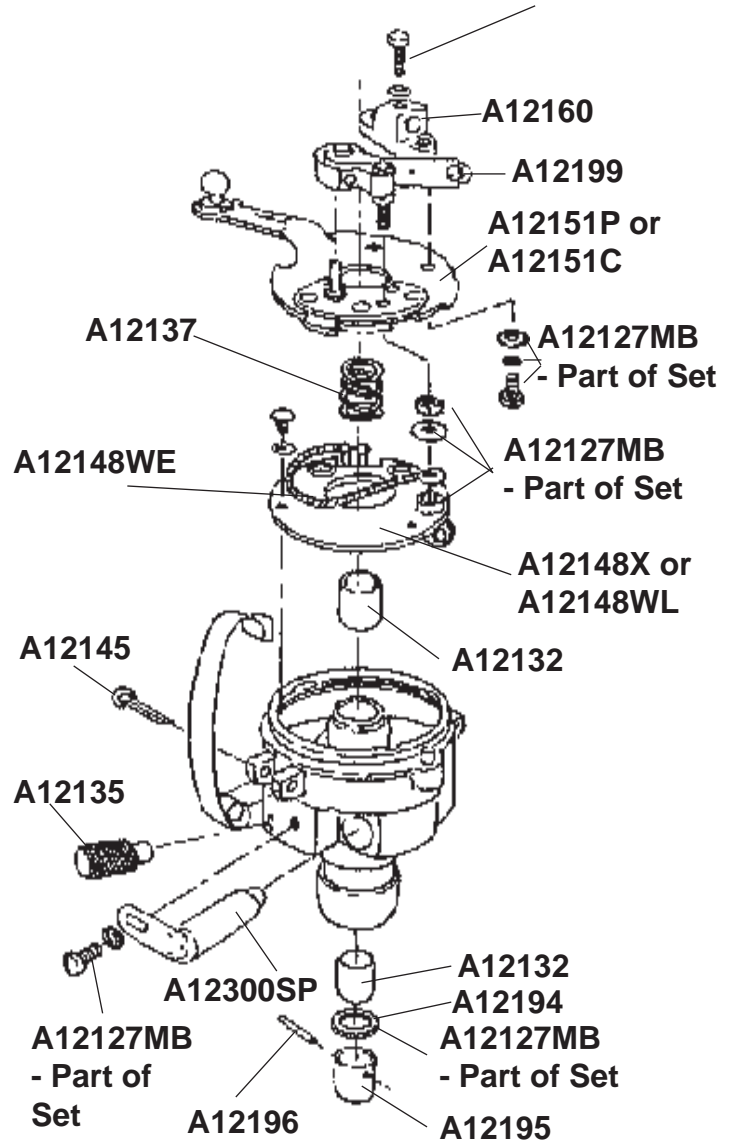
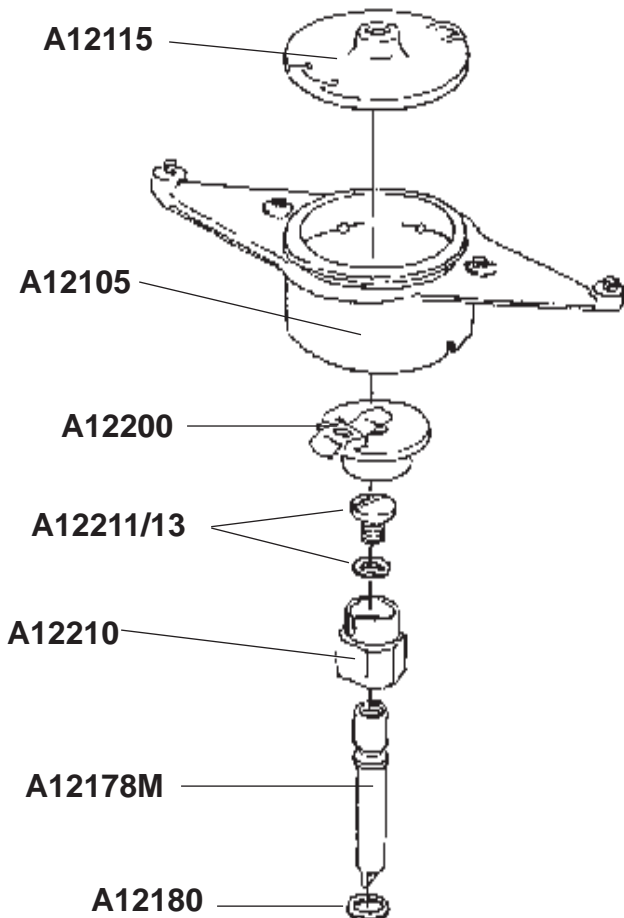

DISTRIBUTOR

Mike's "A" FORD-ABLE Parts

Distributor Lower Shaft

This is the lower shaft that extends from the oil pump drive gear to the upper shaft.



A12249 28-31 Price Ea. \$ 3.55

Coil to Distributor Wire (High Tension Wire)

This is the black lacquered wire with two brass ends which runs from the coil to the distributor. (Original Design.)



A14302 28-31 Price Ea. \$ 1.25

Modern Coil to Distributor Wire (High Tension Wire)

This modern coil wire has the ends crimped in place so you will get a good connection. Also has rubber boots to protect the connectors.



A14302M 28-31 Price Ea. \$ 4.00

Coil (6 Volt)

You must use the coil bracket with this replacement coil. Make sure your coil is positioned correctly on firewall. + passenger / red wire - driver / black wire.

Does not include bracket.

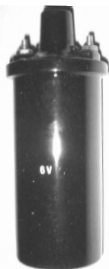

A12000 28-34 Price Ea. \$ 14.95

Coil Bracket

Bracket for mounting your coil. Paint black.



A12000CB 28-34 Price Ea. \$ 3.40

Coil Bracket Mounting Set

Set of screws and lock washers to attach the coil bracket to the firewall. 2 1/4 - 20 x 1/2" & l.w.s



A12000MB 28-31 Price Set/4 \$ 0.45

Script Coil (6 Volt)

This is the metal-enclosed coil with the Ford script. Bracket included.

Script coils were originally used until **March '28** and then again from **July '31** till end.



A12000SC 28-31 Price Ea. \$ 49.95

Coil Resistor

Allows you to use your old 6 Volt coil on a 12 Volt system. The Resistor will dissipate considerable heat.

Instructions Included.



A12001 28-31 Price Ea. \$ 7.95

Coil High Tension Wire Nipples

Set of two wire nipples for the wire that goes from the coil to the distributor. Keeps moisture out and helps align the coil wire.



A12000B2 28-31 Price Pair \$ 0.75

Coil Nut

Two 10/32 slotted round nuts with l/w's and flat washers. Nickel plated.



A12000N 28-29 Price Pair \$ 1.00



Two Raven Hex Nut and Cadmium l/w's and flat washers.

A12003 30-31 Price Set/6 \$ 0.75

Polarity Tester

Put this between the distributor cap and the coil wire to insure everything is working properly. Complete with instructions.



T12116 28-31 Price Ea. \$ 22.95

DISTRIBUTOR

Mike's "A" FORD-ABLE Parts

Spark Tester

Test your ignition voltage by placing this between the distributor cap and the coil wire. Can also help start flooded engines. Complete instructions. This shows how much voltage the system is generating.



T12117 28-31 Price Ea. \$ 18.00

Ignition Tester

Hold this handy tool against the spark plug while the car is running, to see if you are getting spark to the plug.

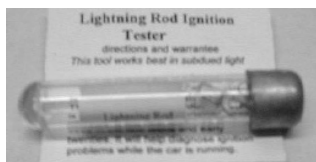

T12118 28-31 Price Ea. \$ 10.75

Timing Kit

Set your own timing with this complete kit with instructions. A timing light is needed for this kit.



T6252 28-31 Price Kit/5 \$ 31.50

EZ Timing Pin Setter

Shown without timing pin (not included). This is an amazing little tool - once you have used it you will tell all your friends.



T6254 28-31 Price Set \$ 9.50

Modern Upper Distributor Plate -

This improved upper plate uses modern Ford points and condenser. Keeps the condenser away from extreme heat and points can be changed without re-timing.



A12151C 28-31 Price Ea. \$ 21.75

Clip for Modern Upper Distributor Plate

This clip allows you to use the modern upper plate A12151C with the modern lower plate A12148WL. Comes with instructions.



A12150 28-31 Price Ea. \$ 1.65



A12150

Wireless Lower Distributor Plate

This improved lower plate eliminates the wire from the lower distributor plate. It has a brass contact ring and a brass contact for the point stud.



A12148WL 28-31 Price Ea. \$ 10.95

Upper Distributor Plate

Excellent reproduction of the upper distributor plate.

See also point block
A12160 - Page Gen. 180.

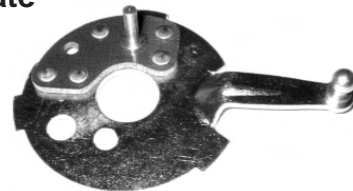

A12151P 28-31 Price Ea. \$ 6.75

Lower Distributor Plate Wire

The cloth-covered wire only for the distributor lower plate. This is the extra length needed for use with the standard lower plate A12151C.



A12148WE Price Ea. \$ 1.35

Distributor Lower Plate

Excellent reproduction of the lower distributor plate with wire pigtail. To be used on a Standard Lower Plate.



A12148X With Long Wire Price Ea. \$ 6.00

Distributor Modern Plate Point & Condenser

Replacement points for the modern upper plate.



A12199MP Points Price Ea. \$ 5.95



A12300MP Condenser Price Ea. \$ 4.25

Distributor Points (Original Style)

Points for the A distributor, complete with the piece that mounts on the point block.



Set gap .018 - .022.
A12199 28-31

Price Set \$ 7.95

DISTRIBUTOR

Mike's "A" FORD-ABLE Parts

Point Mounting Kit

Use with original style points only. This kit contains a thick steel washer, a thin insulating washer and hex nut.



A12199MB 28-31 Price Set \$ 0.75

Distributor Point Washer

This washer goes under the wire terminal on the lower plate wire where it attaches to points. Keeps terminal from shorting out on the plate.



A12199W 28-31 Price Ea. \$ 0.25

Distributor Short-Proof Condenser

This is the improved condenser which won't short out as easily.



A12300SP 28-31 Price Ea. \$ 4.50

Distributor Condenser to Bus Bar Screw & Insulating Washer

Included in the A12127MB Kit. Washer should be glued to the tab of lower plate for easier installation. 1928 thru early 1930 used a 10-32 x 3/8" cad. screw and fiber washer.



A12302A 28-30 Price Set/2 \$ 0.65

Distributor Condenser to Bus Bar Screw & Insulating Washer

Copper plated screw and insulating Washer. Can be seen through the 1/2" hole in the dist.

10-32 x 3/8 Cad. Screw and Fiber Washer.



A12302 30-31 Price Set/2 \$ 0.75

Distributor Hardware Kit

All the screws, rivets, and insulators you need to rebuild the distributor.



A12127MB 28-31 Price Kit/24 \$ 4.25

Distributor Hardware Kit

A very comprehensive and clearly marked set. A more exact set than A12127MB.



A12310A 28-31 Price Set \$ 5.95

Distributor Kits

For the DIYer, everything needed to rebuild with your own distributor housing. Except body, cap & housing.

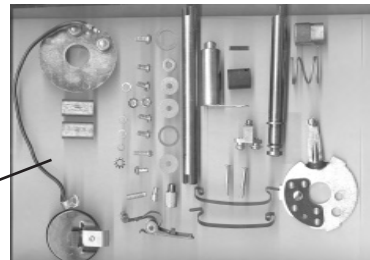

Original

A12127RK 28-31 Price Set \$ 61.95

Modern



Everything you need for a Modern Upper Plate - Except body, cap & Housing.

A12127RKM 28-31 Price Set \$ 69.95

Distributor Base Index Pin

Fits on the bottom of the housing and aligns the distributor to the head.



A12126 28-31 Price Ea. \$ 0.85

Distributor Screw and Lock Nut

This screws into the side of the head to attach the distributor. Do not overtighten - can distort lower bushing causing lockup.



A12127L 28-31 Price Set/2 \$ 1.55

Distributor Bushings

These are the correct bronze type with dimples to hold oil. They press into the distributor housing and should be reamed .500" before installing the dist. Short shaft.



A12132 28-32 Price Pair \$ 2.20

DISTRIBUTOR

Mike's "A" FORD-ABLE Parts

Distributor Bushing Reamer

A quality made spiral piloting reamer. Aligns both bushings while reaming. Not a cheap import. See Mike's Tips on Page 49.



T12132R 28-31 Price Ea. \$ 68.95

Distributor Reamer

This is a cheaper import, but will not do both bushings at the same time. See Mike's Tips on Page 49.



T12132TR 28-31 Price Ea. \$ 21.50

Distributor Oiler

This presses into the side of the distributor. It's spring loaded and nickel plated.



A12135 28-31 Price Ea. \$ 3.40

Distributor Plate Spring

This spring fits between the upper and lower plate.



A12137 28-31 Price Ea. \$ 0.75

Distributor Clamps

These spring clamps hold the body on the housing. Rivets included.



A12144S 28-31 Price Set/4 \$ 4.85

Distributor Clamp Rivets

The special rivets to hold the distributor clamps to the distributor.



A12145 28-31 Price Pair \$ 0.55

Distributor Point Block

This excellent reproduction holds the adjustable half of the points.

Includes 8-32 x 5/16 Screws & Washers and 1 6-32 x 7/16 Screw & Lw.



A12160 28-31 Price Set/7 \$ 4.65



Don't forget Grandfathers Day!! The first week end of every June!! See the back of the general section for your personal invitation.



Gen.180

Give us a call - 1-888-TRY-MIKE (879-6453) Have an "A" Day!

DISTRIBUTOR

SPARK PLUGS

Specifications:

Spark Plugs: Champion 3X, 7/8 - 18 thread
 Spark Plug Gap: .035" (A-6050A head), .030" (B-6050 head), .025" (A-6050B head)

Spark Plugs

Autolite plugs for the A are the best priced plugs.
 Torque to 25 Ft. Lbs.



A12405RE **Need 4** **Price Ea. \$ 3.65**

Spark Plug Terminal Nuts

Used on our A12405RE Autolite Plugs.



A12405REN **Need 4** **Price Ea. \$ 1.80**

Champion "Go" Spark Plugs

For the everyday car, these Champion plugs are excellent.
 Torque to 25 Ft. Lbs.
 Need 4.



A12405 **28-31** **Price Ea. \$ 8.40**

"Show" Spark Plugs

This is the original take apart type plug for those of you who show your car.
 Need 4.



A124053X **28-31** **Price Ea. \$ 26.90**

3X Spark Plug Base

Used only for national judging. This has the correct hex and diamond knurl. Black Oxide finish - correct for the later style 3X plugs.



A12406 **28-31** **Price Ea. \$ 15.75**

Spark Plug Adapters

These adapters screw into the head to allow you to use any modern 14mm plugs.
 8 Piece Set.



A12405ADP **28-31** **Price Set/8 \$ 29.50**

We sell adapters as singles for compression gauge use.

A12405ADPC **28-31** **Price Ea. \$ 7.50**

Spark Plug Nuts

These are the original brass nuts that go on top of the Champion A12405 plug.



A12409 **28-31** **Price Set/4 \$ 1.95**

Spark Plug Gaskets

Copper gaskets with asbestos for the show car.



A12410 **28-31** **Price Set/4 \$ 2.75**

Model "A" Ford Original Wiring

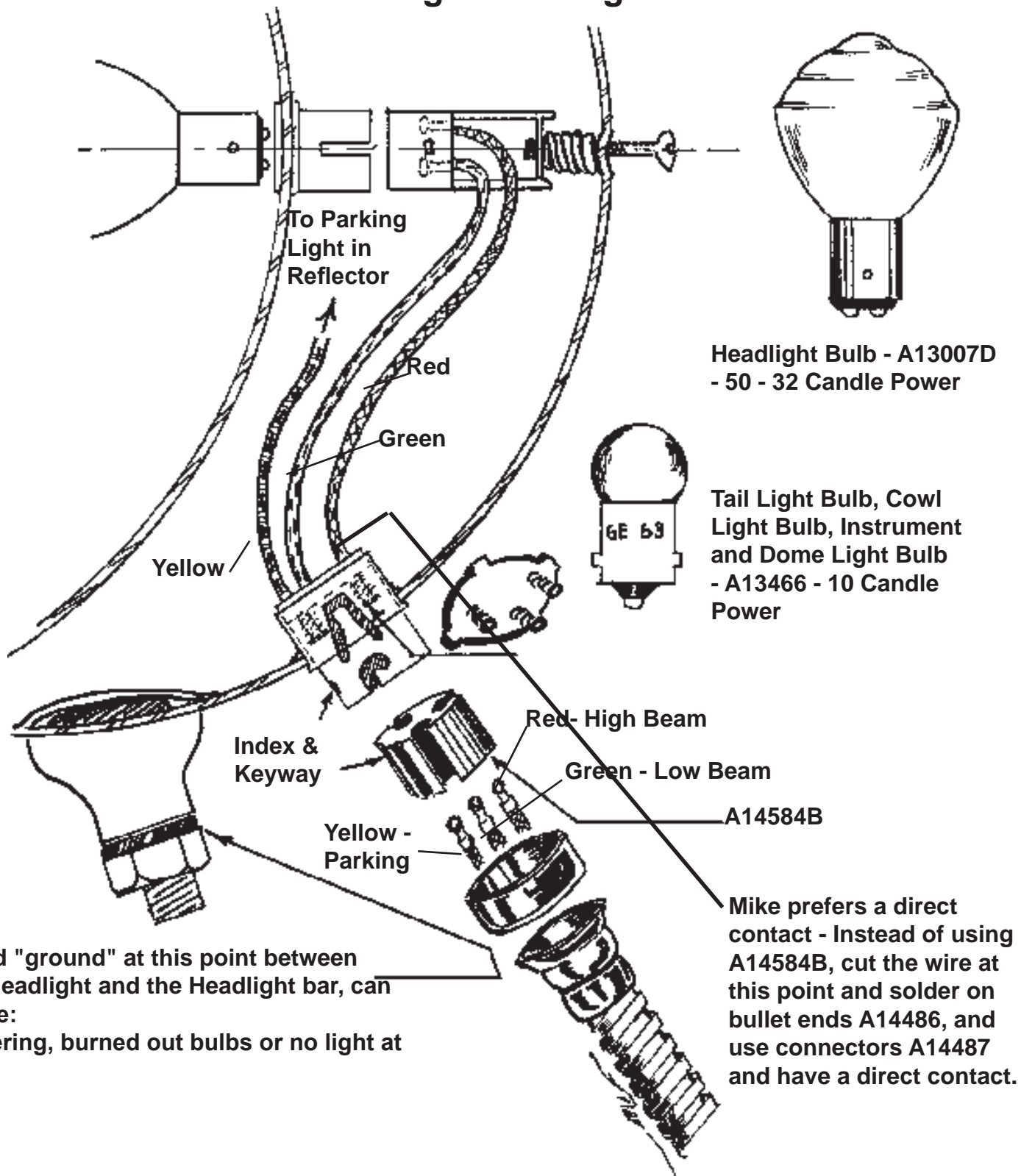

A bad "ground" at this point between the Headlight and the Headlight bar, can cause:
flickering, burned out bulbs or no light at all.

HEADLIGHT

Specifications:

Headlights: 21-21 CP, double contact base, Mazda 1110 (Some 32-21 CP starting in Feb. 1929); 32-32 CP from Nov 30 to end of production 50-32 CP 28-34 6-volt

The following new parts are required to complete a restoration of your Headlights. This is only a guide - do not assume that this is all that is needed, all other parts need to be thoroughly checked.

1. Headlight Mount Bolts-A13002 & Nuts A13003MB
2. Horn and Light Conduit - A14578, AR & SS
3. Headlight Rims - A13001RMAR & RMB
4. Headlight Inner Rings - A13001AIR & BIR
5. Headlight Mounting Bolt Retainer - A13115
6. Headlight Shell Screws - A13011MB
7. Reflectors - A13025B or C
8. Lens - AR13060S & A13060S
9. Latch Repair Kit - A13060
10. Focus Set - A13101/2A or B
11. Bucket Rim Clips - A13021A or B
12. U Clips - A13047
13. Rim Latch Bracket - A13058A or B
14. T Bar - A13046A or A13059
15. Lens Retainer Clips - A13061S
16. Gaskets - A13066
17. Sockets - A13075AR, B1, C1, BR or CR
18. Socket Holder - A13073SA or S
19. Plugs - A14584A or B
20. Bulbs - A13007D or T

Headlight Bulbs

50 candle power for the high beam and 32 candle power for the low beam. The Model "A" came originally with a 32 candle power for the high beam but the 50 candle power will give you better light.

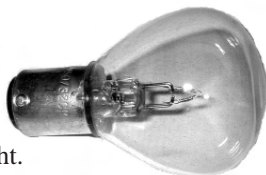

A13007D	28-34	50-32 C.P. Bulb - 6 Volt	
		Price Ea.	\$ 1.55
A13007T	28-31	50-32 C.P. Bulb - 12 Volt	
		Price Ea.	\$ 1.45

Headlight Quartz Bulbs

Replacement quartz bulbs for those who have converted.



B13007Q6	6-Volt	Price Ea.	\$ 16.75
B13007Q12	12-Volt	Price Ea.	\$ 9.35

Headlight Sealed Beam Bulb

This is the bulb you will need if you convert to sealed beams. 7" Across.



A13007SB	6 Volt	Price Ea.	\$ 13.20
A13007SB12	12 Volt	Price Ea.	\$ 8.00

Headlight Sealed Beam Adapter

This kit lets you use modern sealed beam headlights which fit behind the original lens. 8 Piece Set.



A13000ADP	28-31	Price Kit/8	\$ 59.50
-----------	-------	-------------	----------

Headlight Assembly

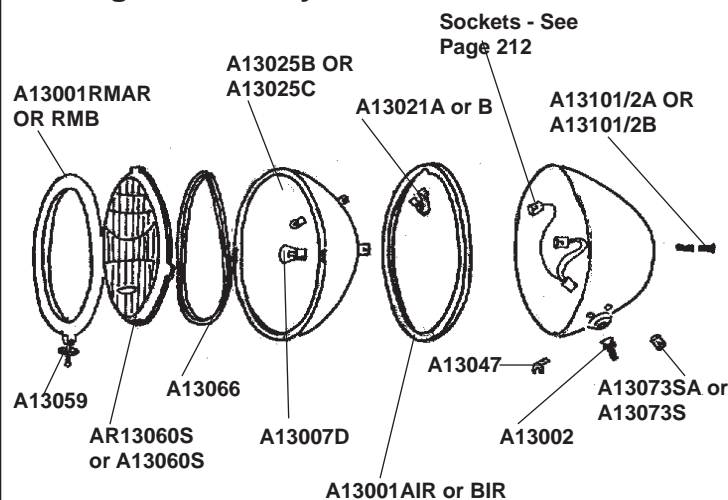

Mike's "A" FORD-ABLE Parts

HEADLIGHT

1928-1929 Headlights

Excellent quality imports ready to bolt on.

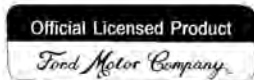

A13000N2	28-29	Nickel 2-Bulb	Price Pair	\$ 335.00
A13000A1S	28-29	Stainless 1-Bulb	Price Pair	\$ 335.00
A13000A2S	28-29	Stainless 2-Bulb	Price Pair	\$ 335.00
A13000AQS6	28-29	Stainless 6 V Quartz	Price Pair	\$ 335.00
A13000AQS12	28-29	Stainless 12V Quartz	Price Pair	\$ 335.00
A13000AQSTS	28-29	12 Volt with Amber Bulb Turn Signal	Price Pair	\$ 363.00

1930-1931 Headlights

Complete stainless steel headlights.
Excellent Quality.



A13000B1S	30-31	Stainless 1-Bulb	Price Pair	\$ 335.00
A13000B2S	30-31	Stainless 2-Bulb	Price Pair	\$ 335.00
A13000BQS6	30-31	Stainless 6V Quartz	Price Pair	\$ 335.00
A13000BQS12	30-31	Stainless 12V Quartz	Price Pair	\$ 335.00
A13000BQSTS	30-31	12 Volt with Amber Bulb Turn Signal	Price Pair	\$ 363.00

Headlight Bar to Fender Patch

A 5" x 7" sheet of metal with the dimple around the holes. A replacement panel for the area that's rusted out on the fender where the headlight bar bolts to the fender.

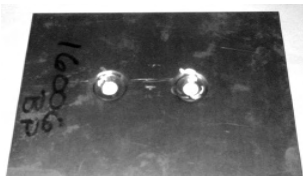

A16006AP	28-29	Price Ea	\$ 9.75
A16006BP	30-31	Price Ea	\$ 9.75

Dropped Headlight Bars

For the Street Rodder, we have these stainless steel dropped headlight bars. **PLEASE NOTE:** Cannot be used with 1932 shells. '30-'31 Shown.



A13114AD	28-29	Price Ea.	\$ 149.95
A13114BD	30-31	Price Ea.	\$ 149.95

Headlight Bonnets

Protect your lenses and lights when not in use with these.



A13050AB	28-31	Black	Price Pair	\$ 28.95
----------	-------	-------	------------	----------

Headlight Mount Bolt

This is the special zinc plated bolt that sticks out of the bottom of the headlight.
1/2" - 20 x 1 1/2".



A13002	28-31	Price Set/3	\$ 6.55
--------	-------	-------------	---------

Headlight Mount Set

Set of two nuts and lock washers to attach the headlight to the cross bar.
Paint Black.



A13003MB	28-31	2 x 1/2" - 20 nuts & l.w.	Price Set/4	\$ 1.10
----------	-------	---------------------------	-------------	---------

Headlight and Horn Conduit Set

These are the chrome conduits for the wire to go through from the radiator shell to headlight and horn. AR fits the early '28 with the 1/2" hole in the back of the headlight.

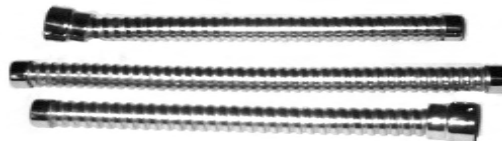

A14578AR	1928	1/2"	Price Set/3	\$ 18.25
A14578	28-31	9/16" Chrome	Price Set/3	\$ 8.50
A14578SS	29-34	9/16" Stainless	Price Set/3	\$ 32.00

Mike's "A" FORD-ABLE Parts

HEADLIGHT

Radiator Shell Grommet Sets

These 3 grommets fit the headlight and horn holes in the radiator shell.



A8210AS	28-29 13/16" Hole	Price Set/3	\$ 2.25
A8210BS	30-31 15/16" Hole	Price Set/3	\$ 2.25

Headlight Conduit Ferrule

Slip this ferrule onto your headlight wire conduits to hold the conduits to the headlight sockets. Stainless Steel. This is included with a conduit set.



A14581	29-31	Price Ea.	\$ 2.40
---------------	--------------	------------------	----------------

Headlight Visors

Jeweled style visors that mount under the rim. See the **body Specific Sections** for Cowl and Tail Light Visors.



A13004J	28-31	Price Pair	\$ 21.95
----------------	--------------	-------------------	-----------------

Headlight Bar Bolts

Cad plated. Used to bolt headlight bar to front fenders. Paint black.



A13130MB	28-31	4 x 3/8" - 16 x 1 3/4" Carriage bolt L.w. & nut	Price Set/12 \$ 3.30
-----------------	--------------	--	-----------------------------

Stainless Steel with polished heads.			
A13130MBSS	28-31	4 x 3/8" - 16 x 1 3/4" Carriage bolt L.w. & nut	Price Set/12 \$ 8.75

Headlight Bar Rubber Pads

These thin rubber pads fit between the headlight bar and the fender. These pads should not be seen when installed.

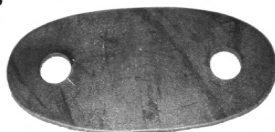

A13130AS	28-29	Price Pair	\$ 1.95
A13130BS	30-31	Price Pair	\$ 1.95

Headlight Quartz Adapter Kit

This lets you modify your headlights to quartz Headlights with the minor job of enlarging the center hole in the reflector and installing this kit.



A13026QH6	6 Volt	Price Kit	\$ 44.00
A13026QH12	12 Volt	Price Kit	\$ 38.50

Complete Headlight Quartz Adapter Kit

Kit comes with sockets, bulbs, reflectors and gaskets for both headlights. Installs in any Model A headlight. Requires an alternator. Looks totally original. You will need 2 of the A13075S. See **Page Gen. 187.**



A13027QK12	28-31	12-volt	Price Kit	\$ 84.65
A13027QK6	28-31	6-volt	Price Kit	\$ 93.50

Headlight Rim

This is a good quality stainless rim for the '28 and '29 A's.



A13001RMAR	28-29	Price Ea.	\$ 52.80
-------------------	--------------	------------------	-----------------

Headlight Rim

This is a good quality stainless steel rim for the '30-'31 A's.



A13001RMB	30-31	Price Ea.	\$ 38.50
------------------	--------------	------------------	-----------------

Headlight Inner Ring

The reflector sets in this ring, must be spot welded to the headlight bucket.



A13001AIR	28-29	Price Ea.	\$ 11.95
A13001BIR	30-31	Price Ea.	\$ 14.70

Mike's "A" FORD-ABLE Parts

HEADLIGHT

Headlight Mounting Bolt Retainer

Holds A13002 (see page Gen. 184) in place inside the headlight bucket with this retainer. Rivet on.

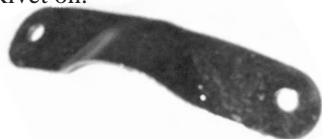

A13115 28-31 Price Ea. \$ 3.35

Headlight Shell Screws

You can use this 36 piece set of smooth screws to replace the original rivets on the bottom plate of the headlight shell. One set does both headlights.



A13011MB 28-31 Price Set/36 \$ 4.85

Headlight Reflectors

Excellent quality with a high shine finish for good reflection.



A13025B 28-31 2-Bulb Price Each \$ 35.75

A13025C 28-31 1-Bulb Price Each \$ 32.50

Fluted Headlight Lens

An exact copy of the fluted lens which was used until 3/29.

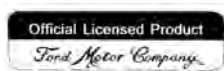

AR13060S 1928 Price Ea. \$ 19.25

Headlight Lens

From March '29 on, Ford used this lens with the Ford script.

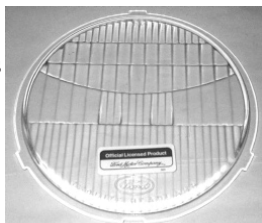

A13060S 29-31 Price Ea. \$ 19.65

Headlight Latch Repair Kit

Repair two damaged rim latches with this all-chrome kit. 6 Piece Set and Instructions.



A13060 28-31 Price Set/6 \$ 3.95

Headlight Focus Set

Screw and spring to adjust the beam; the screw goes through the hole in the back of the headlight and the spring goes between the socket and the back of the light.



10/32 x 1 " for 28-29.
10/32 x 11/16 for 30-31.
A13101/2A 28-29 Price Set/4 \$ 1.40

A13101/2B 30-31 Price Set/4 \$ 1.40

Headlight Latch Springs

This cadmium plated spring is for the headlight latch.



A13017 28-32 Price Pair \$ 0.60

Headlight Bucket Rim Clips

This steel spring clip snaps into the top of the headlight bucket that holds the rim on top.



A13021A 28-29 Price Ea. \$ 2.25

A13021B 30-31 Price Ea. \$ 1.75

Headlight Bucket "U" Clip

The T-bar hooks onto this to hold the rim on at the bottom of the bucket.

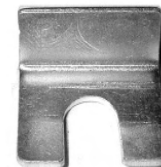

A13047 28-31 Price Ea. \$ 2.15

Headlight Rim Latch Bracket

The latch pivots on this bracket that sticks through the bottom of the headlight rim.



A13058A 28-29 Price Ea. \$ 1.90

A13058B 30-31 Price Ea. \$ 1.90

Mike's "A" FORD-ABLE Parts

HEADLIGHT

Headlight Rim "T" Bar

This is the bar that clips to the U-clip to hold the rim in place.



A13046A	28-29	Nickel	Price Ea.	\$ 2.00
A13059	30-34	Stainless Steel	Price Ea.	\$ 2.00

Headlight Lens Retainer Clips

Set of six wire clips to hold the lens onto the rim.



A13061S	28-31		Price Set/6	\$ 2.25
---------	-------	--	-------------	---------

Headlight Gaskets

These neoprene or cork gaskets set into the reflectors to seal the lens.



A13066	28-31		Price Pair	\$ 2.85
--------	-------	--	------------	---------

Sealed Beam Headlight Socket

If you are converting to sealed beam headlights, you'll need this socket that plugs into the bulb and have a wire pigtail. Need 1 per headlight.



A13075SB	28-31		Price Ea.	\$ 3.30
----------	-------	--	-----------	---------

Sealed Beam Headlight Ferrule

You'll need these if you convert to sealed beam lights; press into the old hole where the socket stuck out to fasten the conduit to.



A13075S	28-31	Not AR	Price Ea.	\$ 5.25
---------	-------	--------	-----------	---------

Headlight Bucket Socket Holder

This piece sits on the shoulder between the headlight bucket and the base plate to hold the headlight socket in place.



A13073SA	1928	3/4" OD Hole	Price Ea.	\$ 3.85
A13073S	29-31	7/8" OD Hole	Price Ea.	\$ 4.85

Headlight Sockets

This is a complete socket assembly for the A's. The earliest '28's had a 5/8" hole in the back, all others had 3/4" holes.

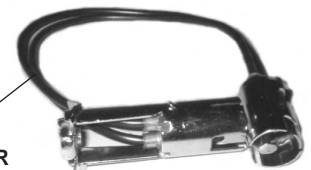

A13075AR	1928		Price Pair	\$ 16.00
----------	------	--	------------	----------

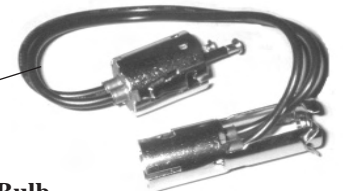

A13075B1	28-29	1-Bulb	Price Pair	\$ 15.75
A13075C1	30-31	1 Bulb	Price Pair	\$ 15.75
A13075BR	28-29	2-Bulb	Price Pair	\$ 16.75
A13075CR	30-31	2-Bulb	Price Pair	\$ 16.75

Headlight Plugs

These plug in at the base of the headlight to keep the wires apart. The '28 includes special brass terminal & screws.



See Page Gen. 182 before purchasing these.



A14584A	1928		Price Pair	\$ 8.50
---------	------	--	------------	---------



A14584B	29-31		Price Pair	\$ 1.65
---------	-------	--	------------	---------

Headlight Bar License Brackets

These brackets attach to the headlight bar to hold your front license.



A13145BK	28-31	Plain steel	Price Set/10	\$ 7.70
A13145SS	28-31	Stainless steel	Price Set/10	\$ 13.70

Mike's "A" FORD-ABLE Parts

HEADLIGHT

License Frames

Show your pride and let others know what year you've got with these aluminum frames with blue lettering on white.

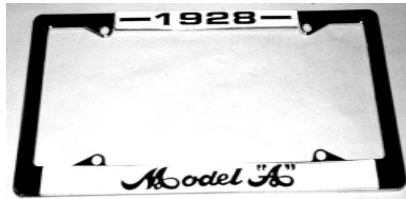

A13146A	1928	Price Ea.	\$ 7.50
A13146B	1929	Price Ea.	\$ 7.50
A13146C	1930	Price Ea.	\$ 7.50
A13146D	1931	Price Ea.	\$ 7.50

License Plates

Show your pride with these blue Ford script with red model year license plates. Mount on the headlight bar or as an extra on the right side.



A13147A	1928	Price Ea.	\$ 8.50
A13147B	1929	Price Ea.	\$ 8.50
A13147C	1930	Price Ea.	\$ 8.50
A13147D	1931	Price Ea.	\$ 8.50

Mike's "A" FORD-ABLE Parts

Horn Assembly

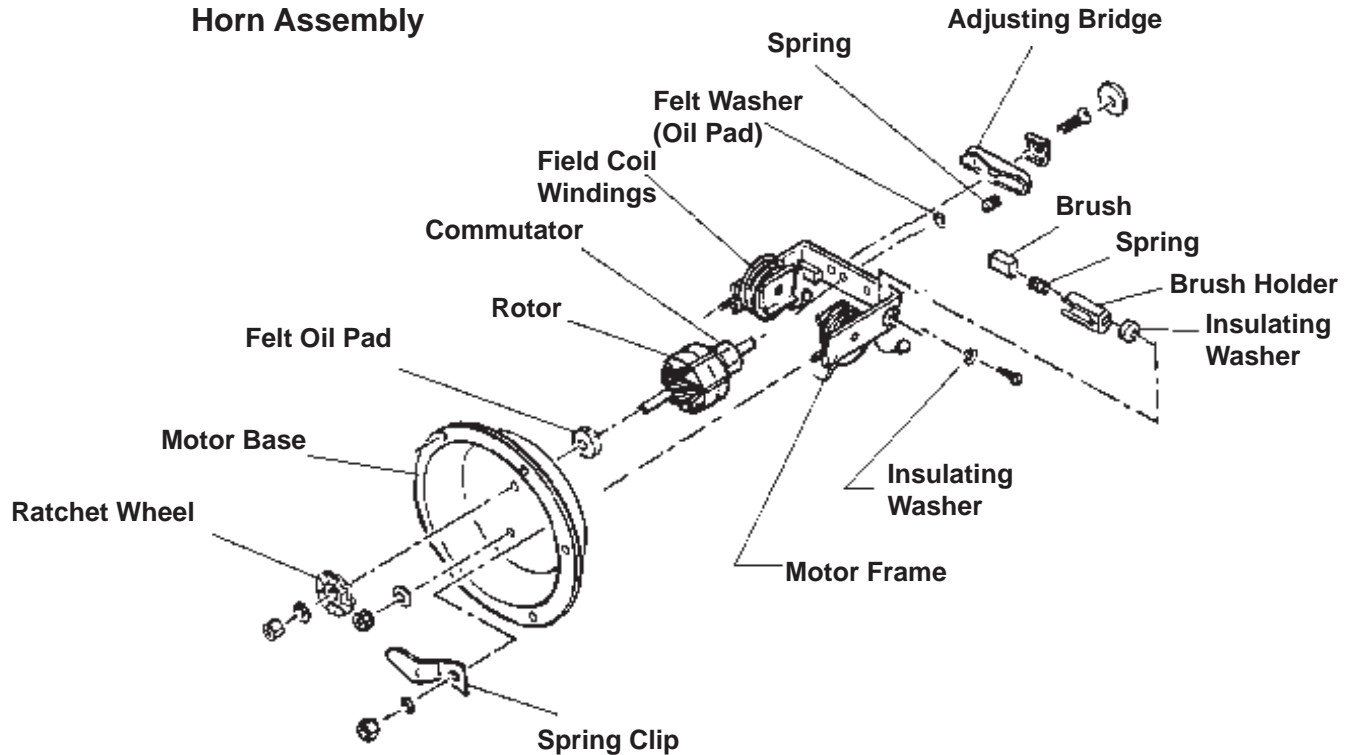

HORN

Having Horn Problems?? Here are a couple of steps to check where the problem could possibly be located, be it wiring, horn rod or ground circuit of the horn.

1. Inspect the wiring - look at your wiring harness, if it does not appear to be in brand new or excellent condition, then replace the wiring harness. The cost of the harness is less than \$40.00, which is much less than the price of a new horn, or even a repair job.
2. Before installing the horn, test the horn with a 6 Volt Battery. Use 2 short pieces of wire to run directly from the battery to the two terminals of the horn. This will assure the horn is working properly. You may be able to use a 6 Volt heavy duty battery charger to perform this test. Do not use any 12 Volt Source.
3. Check for chassis ground this is especially important if you are using the horn relay that mounts inside the horn. The horn relay is depending on a good ground from the frame of the car to the metal frame inside the horn. To complete this circuit, the point where the fender bracket mounts to the frame, the point where the headlight bar mounts to the fender bracket, and the point where the horn mounts to the headlight bar, must all be cleaned of all rust and paint. A good ground must be achieved to complete this circuit. Use sandpaper or steel wool to clean these areas to the bare metal. Use new bolts to mount the headlight bar to the fender.
4. Mount the horn to the headlight bar (without the relay in place), hook up the yellow and blue horn wires to the contacts of the horn. The horn should work. If the horn worked when you tested it with the battery, but it does not work now, find out where the problem is before going any further. Is the horn rod in the steering column in good condition? You can check this by running a test wire from the frame of the Model A to the blue connection on the horn. If the horn works with the

jumper wire, but not with the horn button, then you have a problem with your horn rod.

5. Attach the Relay. The relay will only work if the wiring of the car and the horn rod, and the ground circuit to the horn are all in good condition. Do not attach the relay until you are sure that the horn is working properly.
6. Still won't work - send your horn in to Mikes and we will take a look at it for you.
7. Maintain your horn - use a drop of 3-in-1 oil on the felt washers on the ends of the horn armature. Use alcohol or contact cleaner to clean the brush contact surface. Clean and lube the horn each season or any time the performance of the horn seems to have changed.

Wiring Without Relay

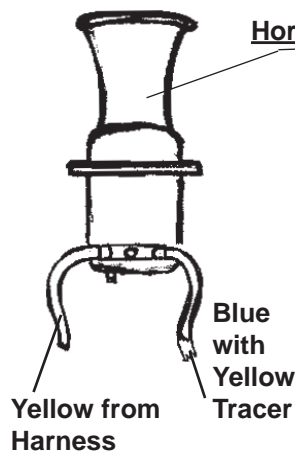

Wiring With Relay

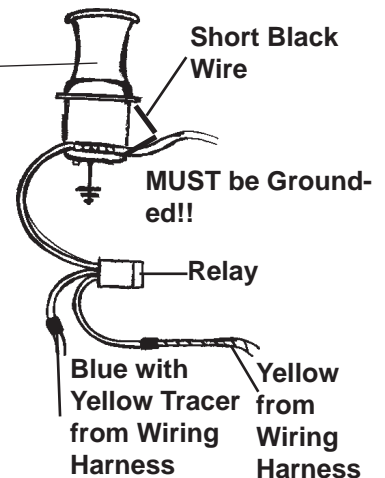

Mike's "A" FORD-ABLE Parts

HORN

Sparton Horn

This is the best quality Sparton horn with mounting bracket. Comes with horn plate. Show Quality. Please note: The 12 Volt horns come with a 6 Volt plate for originality.



A13802 - 6	28-31	6V	Price Ea.	\$ 250.00
A13802 - 12	28-31	12 V	Price Ea.	\$ 255.00

Explosion Whistle, Adapter & Cable Kit

This is a very loud air horn. Especially designed for Model A's. Perfect for Parades. Comes with cable.



A13803	28-31	Price Set	\$ 79.95
--------	-------	-----------	----------

Horn Rebuild Master Kit

If you are needing to rebuild your horn, this kit will do the trick. Includes: Diaphragm, screen, bracket, gaskets, brushes, springs, adjusting cover and flange bolts and nuts.



A13804RK	28-31	Price Set/30	\$ 20.50
----------	-------	--------------	----------

Sparton Horn Plate

If your's is lost or illegible, get this new Sparton horn plate and put it on the back cover of your horn.



A13802P	28-31	Price Ea.	\$ 0.95
---------	-------	-----------	---------

Horn Drive Rivets

This kit has all the drive rivets needed for the Model A.



#100	28-31	Price Set/12	\$ 1.50
------	-------	--------------	---------

Horn Adjustment Screw

This special serrated screw adjusts the tone of the horn.



A13804	28-31	Price Ea.	\$ 1.20
--------	-------	-----------	---------

Horn Bracket

Heavy duty steel bracket, bolt it to the flange on the horn and attach to the headlight bar.



A13805	28-31	Price Ea.	\$ 3.45
--------	-------	-----------	---------

Horn Bell

High quality reproduction with flange with Sparton stamped on it. Screen comes with horn bell (A13840). Powder Coated.



This is not the entire horn.

A13807B	28-31	Price Ea.	\$ 61.95
---------	-------	-----------	----------

Horn Cover Screw

These screws hold the motor cover on. 8-32 x 13/16.



A13809SC	28-31	Price Set	\$ 0.50
----------	-------	-----------	---------

Horn Flange Bolts

Special set of black screws and nuts to attach the horn flanges. Two of the screws are longer to go through the bracket.



A13808BT	28-31	Price Set/14	\$ 2.60
----------	-------	--------------	---------

Horn Motor Cover

This is the correct cover for early '28 Sparton and Stewart-Warner horns but will fit all originals. Has only "adjust" on it.



A13809	1928	Price Ea.	\$ 9.75
--------	------	-----------	---------

Horn Motor Cover

Early to late '28; has "adjust" stamped on it and "Ford" and "Sparton" in raised letters. Will fit other originals as well.



A13809AR	1928	Price Ea.	\$ 11.50
----------	------	-----------	----------

Mike's "A" FORD-ABLE Parts

Horn Motor Cover

From late '28 onward, this cover with "Sparton" in raised letters and "adjust" stamped on it was the one used.



A13809SP Late 28-32 Price Ea. \$ 10.50

Horn Diaphragm

This steel spring diaphragm is the reason the A's had their own sweet sound.

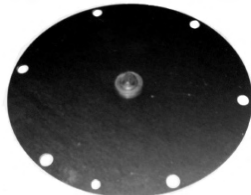

A13811 28-32 Price Ea. \$ 5.80

Horn Gaskets

You'll need a gasket on each side of the diaphragm.



A13812 28-32 Price Pair \$ 1.65

Horn Brush and Spring Set

Brush and springs for the original A horns. 2 Brushes & 2 Springs.

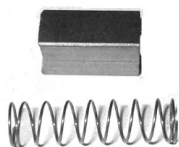

A13817/18 28-31 Price Set/4 \$ 1.95

Horn Terminal Connectors

These terminal connectors go inside the horn and receive the wires from the main wire harness.



A13819 28-31 Price Pair \$ 6.50

Horn Relay

This relay goes inside the horn to boost the power going to it. Instructions Included.

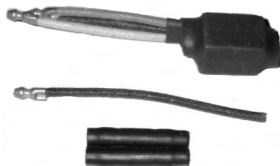

A13820 28-31 Price Set/2 \$ 20.35

Horn Resistor - Voltage Reducer

If you are converting your system to 12 Volt, there is no need to purchase a new horn or going to the additional expense of having yours rewound. Mounts inside the frame rail by the generator and reduces the voltage to 6 Volts to the horn. Instructions Included.



A13820B 28-31 Price Ea. \$ 17.25

Horn Terminal Insulator

This insulator goes inside the horn motor where the wires connect. Set consists of two phenolic brackets, 2 washers, screws, l/w and nuts.

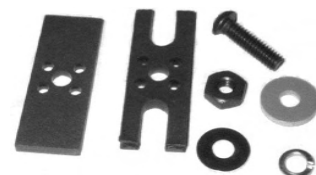

A13821 28-31 Price Set \$ 4.50

Horn Adjusting Bar Cup

To be used on a Sparton horn.



A13823 28-31 Price Ea. \$ 2.60

Horn Ratchet Lock Washer

Special Wide Lockwasher. Holds the round ratchet to the motor base.



A13827 28-31 Price Ea. \$ 1.20

Horn Brush Holder

This secures the spring and brush. Set includes one holder, one tension bus bar, one flat & one cupped insulation washer and one screw. You will need 2 sets per horn. Sparton Horn Only.

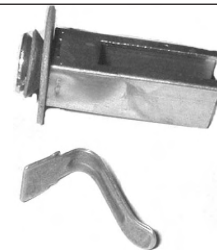

A13829 28-31 Price Set/5 \$ 6.00

Horn Tension Bar

This bar holds the tension on the horn motor brushes.



A13830 28-31 Price Each \$ 1.50

Horn Screen

This screen fits inside the end of the horn bell to keep bugs out.

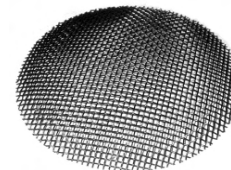

A13840 28-32 Price Ea. \$ 1.75

1928 Horn Screen

For the show car, this has the wire reinforcement inside this flat style screen.



A13840AR 28- Dec. '28 Price Ea. \$ 4.95

HORN

Mike's "A" FORD-ABLE Parts

Horn Motor Ratchet



A13908 28-31 Price Ea. \$ 1.75

Horn Tension Spring

This spring fits inside the horn to maintain tension on the ratchet end.



A13909 28-31 Price Ea. \$ 2.95

Horn Adjusting Bar - Short Style

This short bar fits most but not all horns. This is what the adjustment screw contacts to, to change the tone of the horn. Does not fit all horns.



1 7/16" Long.

A13912 28-31 Price Ea. \$ 4.25

Horn Adjusting Bar

This style bar was specifically produced for Spartan Horns.

1 11/16" Long.



A13912S 28-31 Price Ea. \$ 4.25

Horn Adjusting Bar Spring

This spring maintains the tension on the adjusting bar.



A13916 28-31 Price Ea. \$ 0.95

**Did you know that
you
qualify for a
Discount?**

**Order online at
[www.mikes-
afordable.com](http://www.mikes-afordable.com) for
5% off.**

**This could add up
to more than your
shipping
charges. Just
imagine,
FREE
SHIPPING!!!**

WIRING

The following new parts are required to complete a restoration of your Wiring. This is only a guide - do not assume that this is all that is needed, all other parts need to be thoroughly checked.

1. Wire Harness - either the one bulb harness which is used for 1 bulb in each headlight, the parking lights are the Cowl Lights. The two bulb harness is for two bulbs in each headlight - one main bulb and one parking bulb. No Cowl Lights - **A11646 or A11647**
2. Wire Connector - **A14487**
3. Bullet Ends - **A14486**
4. Frame Rail Wire Clips - **A14585L**
5. Battery Cable - **A14300 or F**
6. Ground Cable - **A14301**
7. Ground Cable to Frame Bolts - **A14301BT**
8. Coil to Distributor Wire - **A14302 or M**
9. Coil to Terminal - **A14305**
10. Terminal to Dash - **A14401B**
11. Cut-Out to Terminal - **A14406 or A**
12. Battery Cable Support - **A14450A or A14450**
13. Terminal Box Grommets - **A14450GR**
14. Terminal Box - **A14560**
15. Headlight Grommet Set - **A8210A or B, A14600AS or BS**
16. Conduits - **A14578, AR or SS**

Voltage Reducer - 12 Volts to 6 Volts

This is a non returnable product - READ INSTRUCTIONS CAREFULLY.

Designed for low amperage loads - 4 Amp maximum and 2 Amp minimum load.



V12873 **28-31** **Price Ea. \$ 12.75**

Battery Cable

This is the correctly braided fabric cable that runs from the battery to the starter. **19" Long.**



A14300F **28-31** **Price Ea. \$ 11.85**

Battery Ground Strap

This is the braided steel ground strap for the A.



A14301 **28-31** **Price Ea. \$ 6.95**

Copper Battery Ground Strap

Ford started out using this flat copper ground strap.



A14301B **28-31** **Price Ea. \$ 12.95**

Battery Ground Cable to Frame Bolt

Here's a bolt, nut, and lockwasher to connect the ground strap to the cross member.

3/8" 24 x 3/4 bolt lockwasher & nut

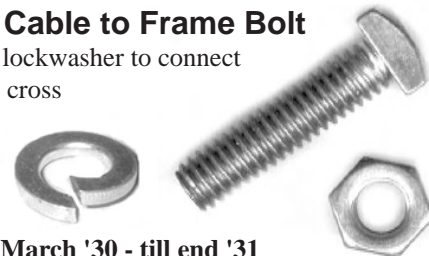

A14300MB **March '30 - till end '31**
Price Set/3 \$ 0.55

Battery Ground Strap to Frame Bolt

This is the special headed bolt with nut and lockwasher that was used from '28 until March '30.

3/8" 24 x 3/4" hex bolt & l.w.



A14301BT **28-30** **Price Set/3 \$ 3.40**

WIRING

Mike's "A" FORD-ABLE Parts

Wiring Harness Installation:

Use wiring diagram to make all connections.

The tail light portion of the wiring harness will run along the left side of the frame, and be held to the frame with 3 clips - A14585L

If the harness is going on a 28-29 with the brake light switch on the transmission, you will have to add about 10" of wire to the brake light wires. These are the two green wires in the middle of the tail light portion of the harness.

The tail light portion of the harness will end at the back cross member of the frame. The tail light wires should be long enough to connect to the harness.

If you are using two tail lights, you will need a tail light crossover wire to make the connection - A14423XO.

If you are using cowl lights, you will need the cowl light cross - A13302C.

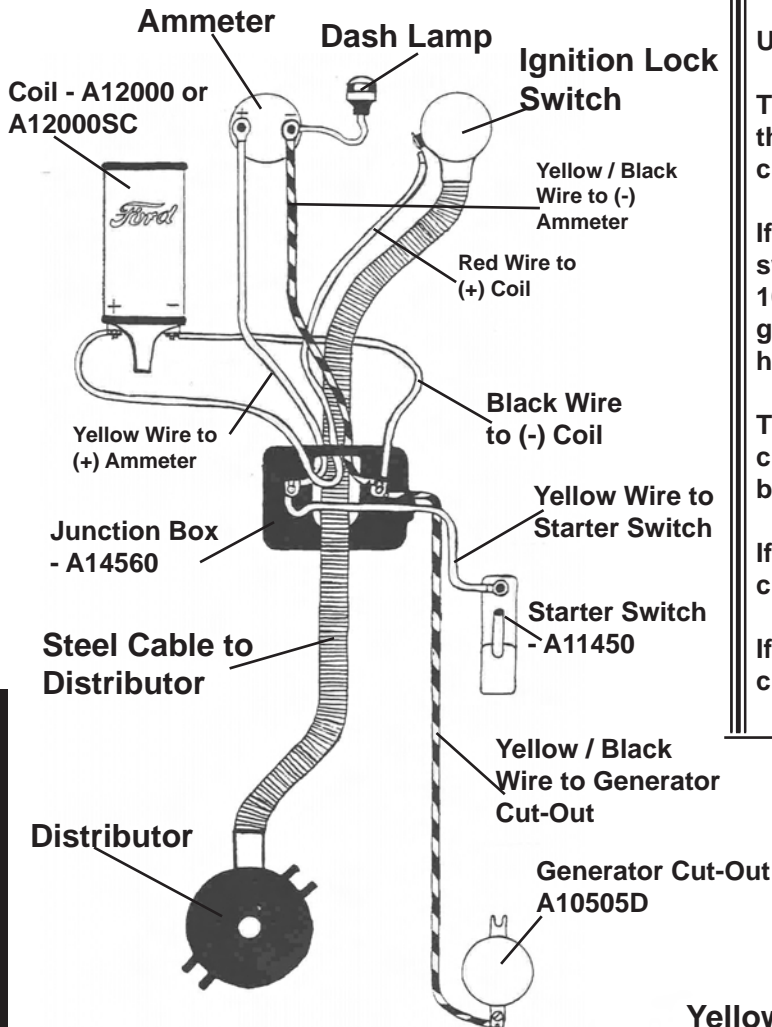

IGNITION WIRING DIAGRAMS

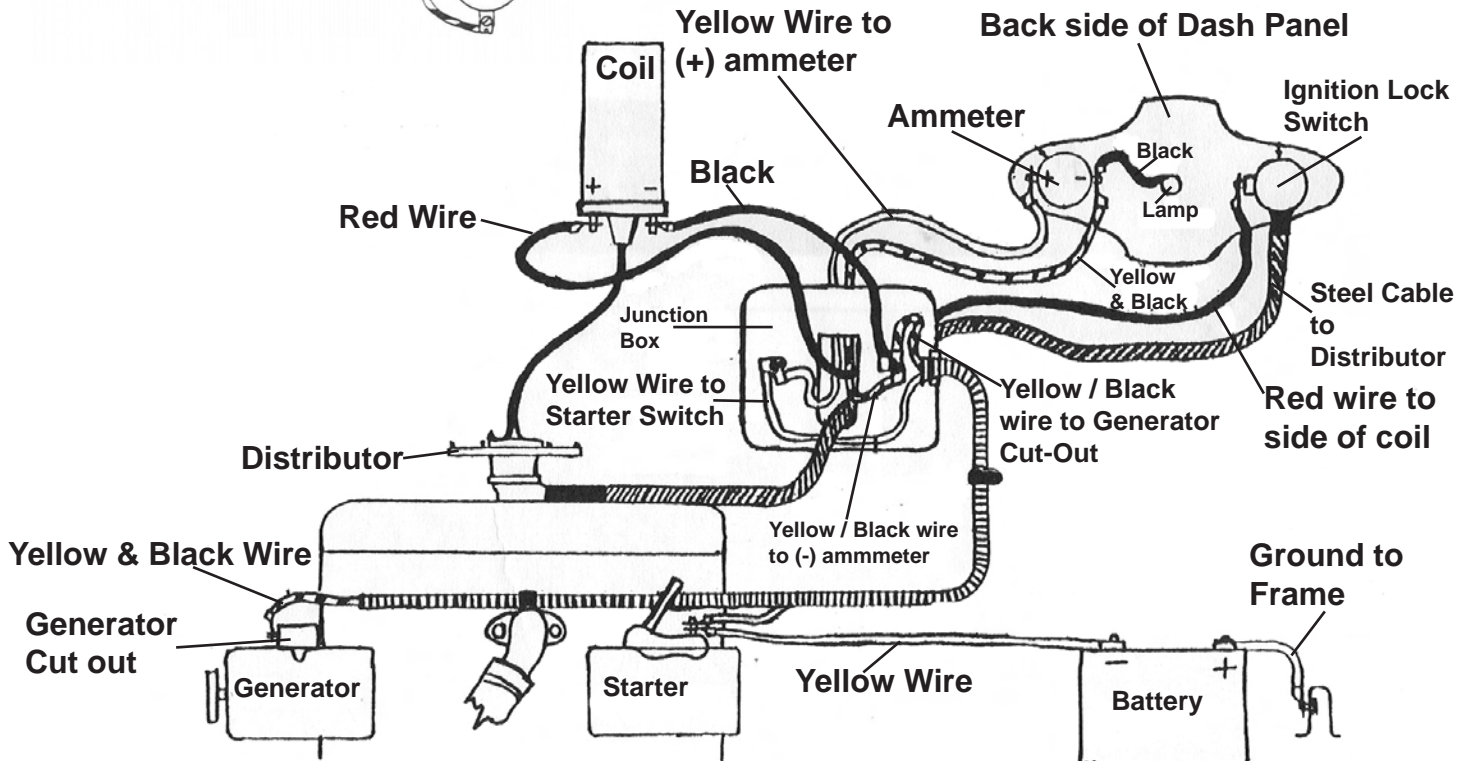

WIRING

Mike's "A" FORD-ABLE Parts

Wiring Diagrams

If you need to do any rewiring, don't take a chance on doing it wrong. These are color-coded and good for all years.

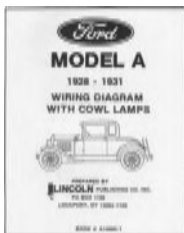

A14350A 28-31 **With cowl lights**
 Price Ea. \$ 8.00

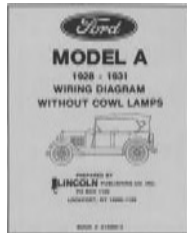

A14350B 28-31 **Without cowl lights**
 Price Ea. \$ 8.00

Bullet Ends

You need to crimp your wires to these terminals to plug into the wire connector (A14487).



A14486 28-31 **Set of 10**
 Price Set/10 \$ 3.05

Bullet Ends - A14486



Connector - A14487

Wire Connector

Set of 10 double female connectors to join one harness to another. Will work with the bullet style wire ends.

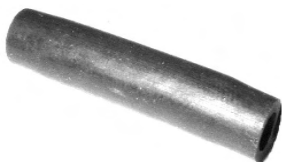

A14487 28-31 **Price Set/10 \$ 4.95**

Electrical Disconnect Switch Cable

No. 1 gauge wire, with eyes on each end. 16" Long. One end goes onto the disconnect switch and the other onto the starter switch.



A14300C 28-31 **Price Ea. \$ 11.95**

Disconnect Switch

This emergency disconnect can be mounted in front of the seat riser on the steel cross member. The battery/starter switch wire is the one spliced into this so you can kill all power if you have electrical problems. Also prevents a thief starting your car. Use cable A14300C & A14300DMB



A14300D 28-31 **Price Ea. \$ 24.30**



A14300SR 28-31 **Same as above, but with plastic Removable Key**
 Price Ea. \$ 19.75

Disconnect Switch Clamp

When purchasing a disconnect switch A14300D you will need to purchase this clamp. It simply bolts onto the bottom bolt on the starter motor, then fit the switch to it. This is the most convenient place for your switch.



A14300DMB 28-31 **Price Ea. \$ 7.95**

Battery Disconnect

This disconnect attaches to the negative pole on your battery. Unscrew the disconnect to cut all power.



A14300DB 28-31 **Price Ea. \$ 12.95**

Coil to Distributor Wire (High Tension Wire)

This is the black lacquered wire with two brass ends which runs from the coil to the distributor. (Original Type). 11 3/4" Long.



A14302 28-31 **Price Ea. \$ 1.25**

Modern Coil to Distributor Wire (High Tension Wire)

This modern coil wire has the ends soldered in place so you will get a good connection. Also has rubber boots to protect the connectors.



A14302M 28-31 **Price Ea. \$ 4.00**

WIRING

Mike's "A" FORD-ABLE Parts

Coil To Terminal Wire

Fits any year A.
See diagram on **Page Gen. 194 & Gen. 195.**



A14305 28-31 Price Ea. \$ 1.95

Terminal Box to Dash Wire

This reproduction is correct in every detail from the correctly colored wire to the correct end clips.
See diagram on **Page Gen. 194 & Gen. 195.**



A14401B 28-31 Price Ea. \$ 7.95

Cut-Out To Terminal Wire

Beginning in February '30, Ford began using this fabric covered wire with flexible black loom.
See diagram on **Page Gen. 194 & Gen. 195.**



A14406 30-31 Price Ea. \$ 7.85

Cut-Out To Terminal Wire

From the beginning of production Feb. '30, Ford used this wire encased in steel conduit.
See diagram on **Page Gen. 194 & Gen. 195.**

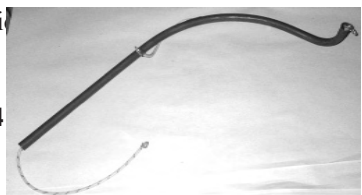

A14406A 28-30 Price Ea. \$ 15.25

Lighting Wire Harness

Harnesses for both one and two bulb headlights. The 1-bulb harness also has a cowl light wire.



See diagram on **Page Gen. 194 & Gen. 195.**

A11646 28-31 One Bulb cowl light Price Ea. \$ 37.75

A11647 28-31 Two bulb Price Ea. \$ 39.50

Lighting Wire Harness with Turn Signals

If you are considering putting Turn Signals into your "A" this would be the harness to get.



A11646T 28-31 1 Bulb with Cowl Price Ea. \$ 115.00

A11647T 28-31 2 Bulb without Cowl Price Ea. \$ 123.00

Water Inlet Wire Clip Bolt (Hex)

This short, fine-threaded bolt with lock washer is used to attach the wire clip (A14577A) to the water inlet.



A14576MB 28-31 1/4" - 28 x 1/2" hex bolt Price Set/2 \$ 0.35

Water Inlet - Speedo Cable & Cut-out Wire Clip

This wire clip was used in several places by Ford: for the water inlet and speedometer cable inside the firewall for all years; for the cutout wire on the firewall in 30-31.



A14577A 28-31 Price Ea. \$ 1.50

Firewall Wire Clip

This wire clip was used only for the early steel conduit style of cutout to terminal box wire; attaches on the firewall.



A14577B 28 - Feb. '30 Price Ea. \$ 1.55

Firewall Wire Clip Bolt (Round)

This is the correct round head screw with lock washer to attach the wire clip to the firewall. Paint Black. Use with A14577A & B.



A14577BR 28-31 12/24" x 1/2" screw & l.w. Price Set/2 \$ 0.40

Light Wire Harness Clip

This clip holds the main lighting wire harness onto the left frame rail under the hood latch.



A14598 28-31 Price Ea. \$ 1.75

Wiper and Dome Lamp Wire Support

This clip was held in place by a bolt that held the gas tank to the cowl. It served as a grommet holder for the wiper and or dome lamp wire, and the other part of the clip held the top of the kick panel in place.



Grommet included. 2 Required.
A14591 28-29 Price Ea. \$ 4.30
A14591GR Grommet Only Price Ea. \$ 0.70

Mike's "A" FORD-ABLE Parts

Battery Cable Support

This support bolts onto the bell housing to ensure your battery cable doesn't rub against the pedals and short out.

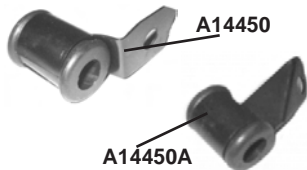

A14450A	28-29	Price Ea.	\$ 5.00
A14450	30-31	Price Ea.	\$ 3.00

Terminal Box Cable Support Grommet

This is an extra grommet for the cable support or terminal box.



A14450GR	28-31	Price Ea.	\$ 1.25
----------	-------	-----------	---------

Authentic Terminal Box Cable Grommet

For the show car buff, this exact copy of the original Battery Grommet with two grooves inside for the cable end to pass through.



A14550OR	28-31	Price Ea.	\$ 14.50
----------	-------	-----------	----------

Terminal Box (Junction Box)

Bakelite like original. This is a complete terminal box with mounting hardware, wing nuts, and cover.

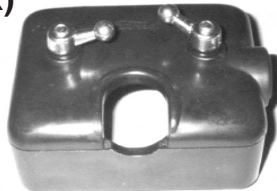

A14560	Ford Script	Price Ea.	\$ 10.95
A14560P	No Script - Plain	Price Ea.	\$ 8.50

Terminal Box Lid

Bakelite like original. This is the terminal box cover only.



A14561A	Ford Script	Price Ea.	\$ 3.05
A14561P	No Script - Plain	Price Ea.	\$ 3.10

Terminal Box Brass Wing Nuts

Here are two wing nuts for the terminal box; brass so they won't rust. 2 x 10-32 Brass Plated Nuts.



A14561WN	28-31	Price Pair	\$ 1.35
----------	-------	------------	---------

Wing Nut Kit

For the show car, these insulated terminal box wing nuts are the correct dull brass color. Kit includes 4 fiber washers to be used as needed under each nut so the nuts cover the studs.



A14561X	28-31	Price Set	\$ 3.95
---------	-------	-----------	---------

Terminal Box Screws

These are the 4 screws with lock washers needed to mount the terminal box to the firewall.



4 x 10-32 x 3/8 Screws and Lockwasher.

A14560MB	28-31	Price Set/8	\$ 0.75
----------	-------	-------------	---------

Radiator Shell Grommet Sets

These 3 grommets fit the headlight and horn holes in the radiator shell.



A8210AS	28-29	13/16	Price Set/3	\$ 2.25
---------	-------	-------	-------------	---------

A8210BS	30-31	15/16	Price Set/3	\$ 2.25
---------	-------	-------	-------------	---------

Headlight Conduit Set

These are the chrome conduits for the wire to go through from the radiator shell to headlight and horn. AR fits the early '28 with the 1/2" hole in the back of the headlight.



A14578AR	1928	5/8" Chrome	Price Set/3	\$ 18.25
----------	------	-------------	-------------	----------

A14578	29-31	9/16" Chrome	Price Set/3	\$ 8.50
--------	-------	--------------	-------------	---------

A14578SS	29-31	9/16" Stainless Steel	Price Set/3	\$ 32.00
----------	-------	-----------------------	-------------	----------

Headlight Conduit Ferrule

Slip this ferrule onto your headlight wire conduits to hold the conduits to the headlight sockets. Stainless Steel. This is included with a conduit set.



A14581	29-31	Price Ea.	\$ 2.40
--------	-------	-----------	---------

Mike's "A" FORD-ABLE Parts

Headlight Plugs

Here are the black plastic inserts that fit in the base of the headlight where the wires come together. This keeps the wires from shorting out. See **Page Gen. 182** before purchasing these.

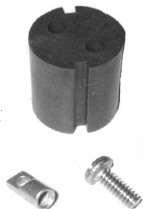

2 wire only Includes special brass terminal and screws
A14584A 1928 Price Pair \$ 8.50



A14584B 29-31 Price Pair \$ 1.65

******* MIKE'S TIPS *******

Mike recommends a slight deviation on wiring your headlights. The original wiring has a tendency to create shorts where the two wires join. Rather use an empty socket assembly and connect the wires directly eliminating the plastic plug all together. See Page 182.

Frame Rail Wire Clips

Here's a pack of 10 wire clips to hold the wires onto the frame rails.

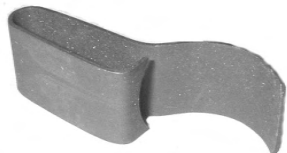

A14585L 28-48 Price Set/10 \$ 2.50

Firewall Grommet Set

Here is a complete set of grommets you need for the firewall. The late '31's had an indented firewall for the gas valve.



A14600AS 28-31 Price Set/6 \$ 4.00



A14600BS 1931 Price Set/7 \$ 5.50

Wire Sold by the Foot

Authentic cloth covered 14 Gauge Wire. As this is cut to order, we do not accept returns.



A14303BL	Black	
A14303B	Blue	
A14303G	Green	
A14303R	Red	
A14303Y	Yellow	
A14303BG	Black with Green Tracer	
A14303BR	Black with Red Tracer	
A14303BY	Black with Yellow Tracer	
		Price per Ft. \$ 0.55

WIRING

FIBERGLASS FENDERS

Please read carefully before purchase.

A complete line of fiberglass fenders are available. Welled fenders refers to those with the tire well for the spare. These are all hand laminated with fiberglass matte and special resins to achieve the optimum in strength. **Please Note: Additional shipping will apply due to large boxes.** These are special orders, please allow three to four weeks for delivery. Front Fenders may be shipped via a Freight line due to size. Rear fenders will be shipped by UPS.



1928 - 1929 Front Fenders

F16006A	Plain Left	Price Ea.	\$ 230.00
F16005A	Plain Right	Price Ea.	\$ 230.00
F16036A	Standard Well - Left	Price Ea.	\$ 360.00
F16035A	Standard Well - Right	Price Ea.	\$ 360.00

1930 - 1931 Front Fenders

F16006B	Plain Left	Price Ea.	\$ 230.00
F16005B	Plain Right	Price Ea.	\$ 230.00
F16036B6	Standard Well - Left	Price Ea.	\$ 360.00
F16035B6	Standard Well - Right	Price Ea.	\$ 360.00

1928 - 1929 Coupe, Roadster, Pickup Rears

F16161A	Left	Price Ea.	\$ 199.00
F16160A	Right	Price Ea.	\$ 199.00

1930 - Early 1931 Coupe, Roadster & Narrow Box Pickup Rears

F16161B	Left	Price Ea.	\$ 199.00
F16160B	Right	Price Ea.	\$ 199.00

1928 - 1929 Sedan and Phaeton Rears

F16311A	Left	Price Ea.	\$ 199.00
F16310A	Right	Price Ea.	\$ 199.00

1930 - 1931 Sedan and Phaeton Rears

F16311B	Left	Price Ea.	\$ 199.00
F16310B	Right	Price Ea.	\$ 199.00

FIBERGLASS FENDERS

STEEL FENDERS

Please read carefully before purchase.

It is important when fitting sheet metal to your car to **FIRST** fit before painting or drilling any holes. Many times it is necessary to use C-Clamps, vise grips or a drift pin to locate holes for alignment. In order to secure a proper fit and alignment, it is normally necessary to loosen all attaching sheet metal parts. Some reworking may be necessary as mating parts many come from different suppliers or new parts versus 80 year old parts are placed together. Some metal parts may have been treated with oil or may still have residue from forming oils. It is necessary to thoroughly clean the metal with a metal prep or solution to remove all oils and / or fingerprints before painting.

NO RE-WORKED OR PAINTED PARTS ARE ACCEPTABLE FOR RETURN.

Front Fenders

PLEASE NOTE: All fenders are sold "AS IS" with absolutely NO guarantee. The best available. Original gauge steel with the serrated wire bead edge. **Can now be shipped by Couriers.** Average shipping charge is \$90.00 - \$130.00 per fender.

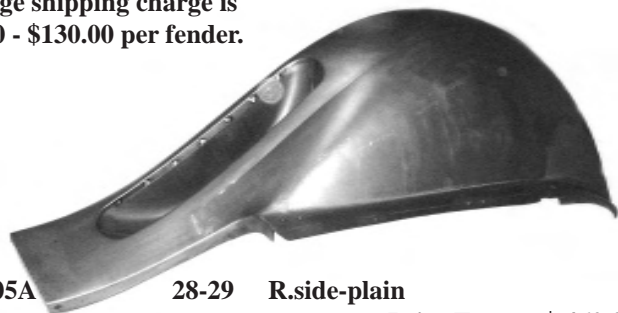

A16005A	28-29	R.side-plain	Price Ea.	\$ 460.00
A16005C	30-31	R.side-plain	Price Ea.	\$ 460.00
A16005AW	28-29	R.side-welled	Price Ea.	\$ 560.00
A16005CW	30-31	R.side-welled	Price Ea.	\$ 560.00
A16006A	28-29	L.side-plain	Price Ea.	\$ 460.00
A16006C	30-31	L.side-plain	Price Ea.	\$ 460.00
A16006AW	28-29	L.side-welled	Price Ea.	\$ 560.00
A16006CW	30-31	L. side-welled	Price Ea.	\$ 560.00

Rear Fenders

These are very well-made reproductions using the same gauge steel as Ford used. They fit the **Coupe, Roadster and Pick-Up. NOT FOR THE WIDE BED PICKUP. SOLD IN PAIRS ONLY!**

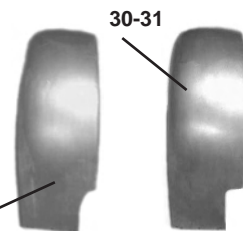

A16160/61A	28-29	Left & Right	Price Pair	\$ 560.00
A16160/61B	30-31	Left & Right	Price Pair	\$ 560.00

Sedan Rear Fenders

These well-made fenders fit the **Victoria's**. Same gauge steel that Ford used.

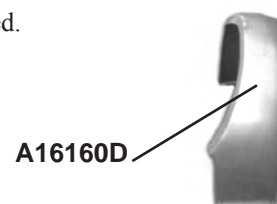

A16160/61C	30-31	Left & Right	Price Pair	\$ 620.00
A16160/61D	28-29	Left & Right	Price Pair	\$ 620.00

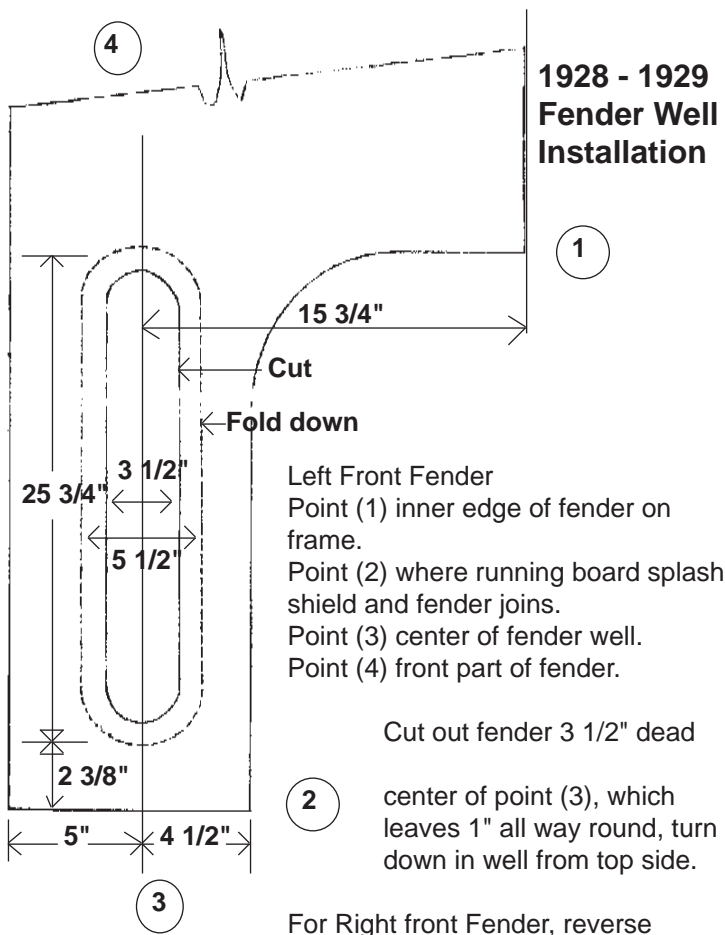

Mike's "A" FORD-ABLE Parts

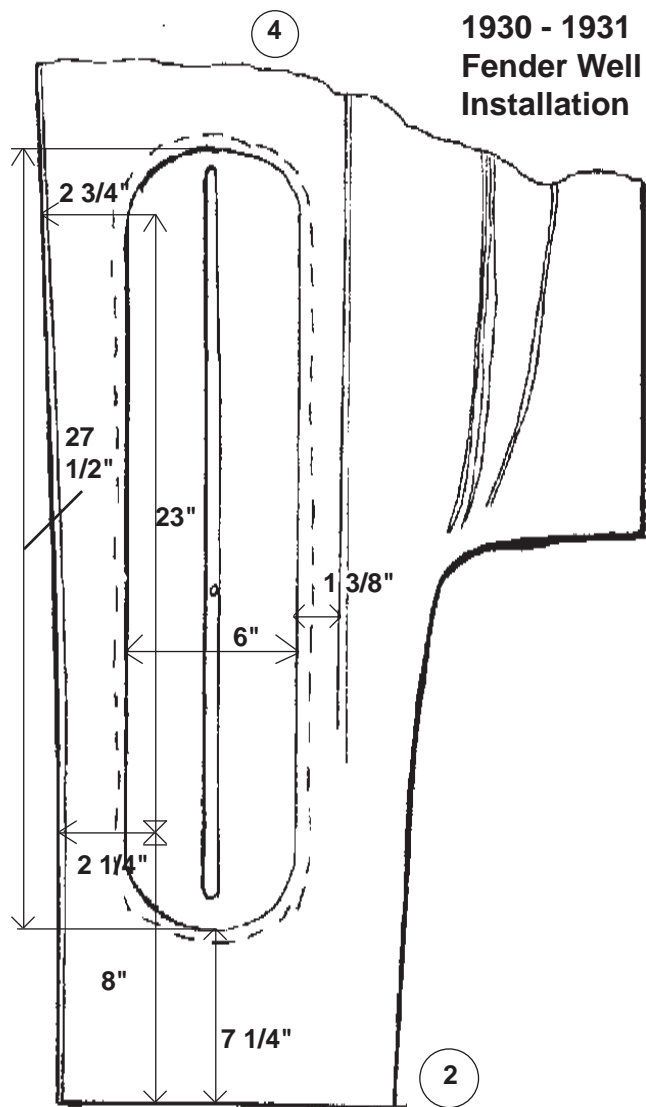

1930 - 1931 Fender Well Installation

Left Front Fender

- Point (1) inner edge of fender on frame.
- Point (2) where running board splash shield and fender joins.
- Point (3) center of fender well.
- Point (4) front part of fender.

Cut our fender 6" dead center of point (3) which leaves 1" all way round - turn down in well from top side.

For right Front Fender, Reverse diagram.

PLEASE NOTE: All measurements on 28-29 and 30-31 Fender Well Diagrams are to be used as guidelines only. Mike's cannot be responsible for damaged fenders.

Fender Welt

This is a 17 Ft. roll of fender welt with a 3/16" bead. One roll is enough for your whole car. Ford did not use welt across the ends of the running boards.



A3404FW Price Per Roll \$ 9.90

Fender Wells

Good heavy steel, these are wells that get welded into the fender for a spare tire.

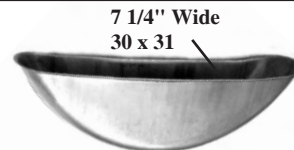

6 1/2" Wide
28 x 29



A16029 28-29 Price Ea. \$ 33.95

A16031 30-31 Price Ea. \$ 31.95

Fender Covers

This is a wonderful gift idea. Protect your fenders from dropped tools and belt buckles. These covers are made out of a heavy duty leather grain vinyl with a soft foam back that keeps the fender cover firmly in place. The covers work equally well on both '28-'29 and '30-'31 fenders. If you have a side mounted spare, just cut on the dotted lines.

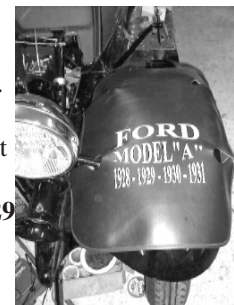

A16156 Price Ea. \$ 19.95

Rear Fender Step Plate Cover

Protect your paint!! Place this cover over your Rumble Step Plate **A41563S** (See any Car Specific Section that has a Rumble Section - like Coupe Page 24) or **A41563R**, when you have passengers climbing in or out. These will work on any car with a rumble seat. Comes pre-cut for the round step plate and is clearly marked to be cut for the square plate.

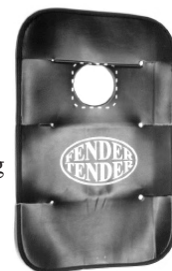

A16157 28-31 Price Ea. \$ 13.25

FENDER BRACKETS

Fender Hole Patch

These handy patches make it easy to repair dimpled holes in the front fenders.



6000 Price Set / 4 \$ 7.50

Headlight Bar Patch

This patch makes it simpler to repair any damage on your front fender where the headlight bar attaches.

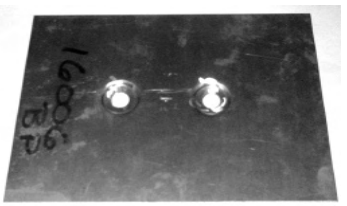

6006AP 28-29 Price Ea. \$ 9.75
 6006BP 30-31 Price Ea. \$ 9.75

Fender Bead Reinforcement Piece

These clips fit between the fender and fender bracket to prevent the fender from being damaged when the bolts are tightened. Used on all 4 fenders.



6100 28-31 Price Ea. \$ 4.25

Fender Edge Bolt Set

This set contains the hardware you'll need to connect the fender brackets to the outside edge of the fender. 1/4 x 20 Carriage bolts, Lockwashers & nuts.



6100MB 28-31 Price Set/12 \$ 1.95

Fender And Running Board Bolt Sets

63-A 1928 176 Piece - Cast Iron Running Board & Fender Brackets Price Set \$ 15.50
 63 28-29 176 Piece - Stamped Steel Running Board & Fender Brackets Price Set \$ 17.25
 64 30-31 204 Piece - Stamped Steel Running Board & Fender Brackets Price Set \$ 15.50

Front Fender Bracket Bolts

Set of bolts, lock washers, and nuts to mount both cast fender brackets to the frame.



2 x 1/2" - 20 x 1 9/16 + 4 x 3/8" - 24 x 15/16 l.w. & nuts.
 A16026MB 28-31 Cast Fender Brackets Price Set/18 \$ 3.70



6 - 3/8" - 24 X 3/4 Bolts, L/w and Nuts.
 A16027MB Mid 30-31 Stamped Steel Brackets Price Set/18 \$ 3.75

Front Fender Bracket Bolts

Late '31 Brackets.



2 x 3/8" - 24 X 1 15/16" + 4 x 3/8" - 24 x 15/16" 6 l/w and 6 nuts for both brackets.
 A16028MB 1931 Used on Stamped Steel Brackets with a raised center reinforcing rib. Price Set/8 \$ 3.50

Rear Fender Bracket Bolts

This set of bolts and castle nuts will attach both rear fender brackets to the body.



Not for Pickups. A16181MB 29-31 6 5/16" - 24 x 1" + l.w & nuts Price Set/18 \$ 2.50

Rear Fender Bracket Bolts

Closed Cab Pickup with narrow Box, fender Brace Bolts. 1928 - May 1931.

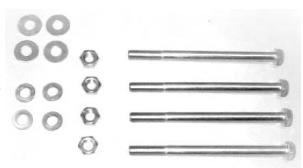

4 5/16-24 x 4 1/2" Bolts, flat Washers, l/w, and nuts. A16181C 28-31 Price Set \$ 3.25

Rear Fender Washers & Nuts

If your studs (A081MB - See Page 203) are OK, then this set of 8 Flat Washers, Lockwashers and 5/16-18 Nuts are used to mount rear fenders to body.



A16195 29-31 Price Set/24 \$ 1.50

Rear Fender Mount Studs

These are the special oversized head bolts that get welded or brazed to the body to mount the rear fenders on.



A081MB 28-31 4 studs needed per fender
 Price Ea. \$ 0.50

Front Fender Bracket

This is a quality reproduction of the bracket for the '28-'29's. Stamped Steel.



For Rear Fender Brackets see the "Rear Fenders & Brackets" Section in the Body Style Sections.

A16025AP 28-29 Price Ea. \$ 31.00

Front Fender Bracket

This is the stamped designed bracket for the '30-'31's.



For Rear Fender Brackets see the "Rear Fenders & Brackets" Section in the Body Style Sections.

A16025B 30-31 Price Ea. \$ 31.00

Fender Welt

Mike has this 17 foot roll of the 3/16" black beading used on the fenders.



A3404FW 28-31 Price Ea. \$ 9.90

SPLASH SHIELDS

Frame Welt

This treated webbing won't rot away when installed on your frame rails. (Enough for one car).



A3407X 28-31 Price Ea. \$ 16.50

Splash Shield Bolts

A set of 4 large-headed carriage bolts with nuts to attach the shields to the frame. Included in Set #43, #43A & #44
4 x 1/4-20 x 3/4" l.w. & nuts



A040MB 28-31 Price Set/8 \$ 2.20

Splash Shields for 1928-1929

In mid-'28, Ford introduced a shield with a hump to add more room for the new braking system. Early '28's had no hump. 68" Long.



AM150/151 1928 Without hump
Price Pair \$ 165.00

AM152/153 28-29 With Hump
Price Pair \$ 165.00

Splash Shield -

One Piece shields are the same length as the running boards including the nose cone, see AM150/152 '28 - '29 and AM158 1931. Two Piece Splash shields were used from January 1930 till September 1930 and had to have the nose cones welded to the fender.

1930 Splash Shield

If your boards are in good shape, you can replace your shield for the '30 A with this pair. Nose sections can be purchased separately (AM156, AM156HR, AM157, AM157HR).

See Page Gen. 206 With Running Boards attached.



AM154/155 1930 Used Jan 30 to Sept. 30
Price Pair \$ 111.50

Splash Shields

These fit all Fords from 9/'30 until the end of production. Show Quality.



AM158 Late 30-31 Price Pair \$ 169.00

Hole for Side Mount Spare Wheel - Make double sure of your hole position before you start cutting your shields.

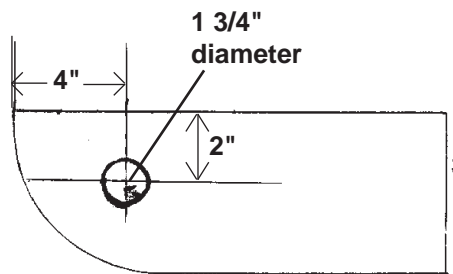

30 - 31 Only

Splash Shield Nose Sections

These are the steel nose sections which fit between the front fender and the short splash shields. Used only from Jan - Sept. 1930.



AM156 1930 Right Price Ea. \$ 55.00
AM156HR 1930 Right Hole

Price Ea. \$ 58.50
AM157 1930 Left Price Ea. \$ 55.00

AM157HL 1930 Left Hole
Price Ea. \$ 58.50

SPLASH SHIELDS

SPLASH APRONS

Radiator Splash Apron & Bumper Bracket Assembly

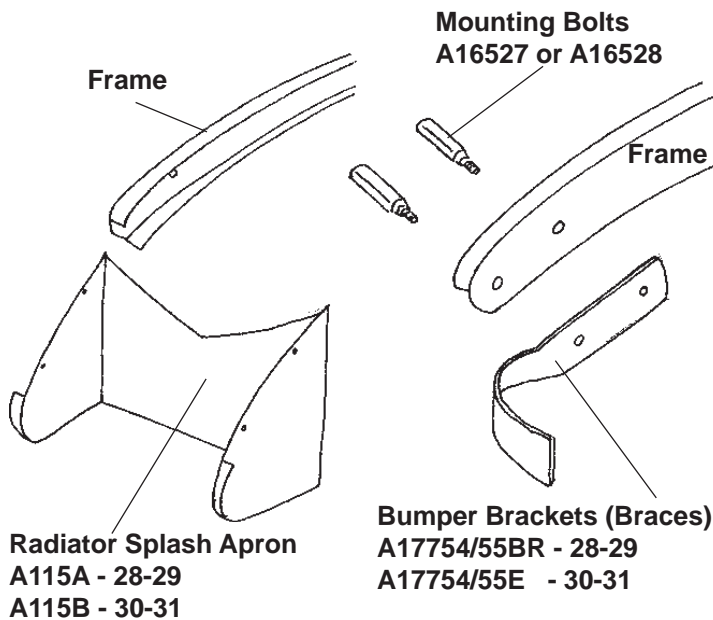

Radiator Splash Aprons

These are formed steel radiator aprons which fit under the radiator on the front. 4 x 1/4-20 D-Nuts are already installed on the '28-'29's.

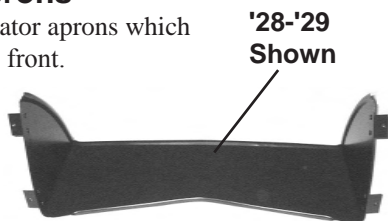

Order Bolts **A16528AS** for '28-'29
Order Bolts **A16528BS** & #24 for '30-'31.

A115A	28-29	Price Ea.	\$ 45.00
A115B	30-31	Price Ea.	\$ 55.00

Radiator Apron Mounting Bolts

This a replacement style with round stock instead of hex shape. They function just as well. Order the **A16528BS** Separately.



A16527	30-31	Price Set/16	\$ 6.00
---------------	--------------	---------------------	----------------

Radiator Shield Mounting Bolts

This set of hex-shaped bolts, washers, and nuts was used to mount both the radiator splash shield and the front bumper brackets.



A16528	30-31	Price Set/20	\$ 19.00
---------------	--------------	---------------------	-----------------

Radiator Splash Apron Screws

These screws pass through the hood shelf and frame to a "D" nut on the Splash Shield.

4 x 1/4-20 x 1 1/4 Oval Head Screws.



A16528AS	28-29	Price Set/4	\$ 1.25
-----------------	--------------	--------------------	----------------

Canadian Radiator Splash Apron Screws Only

Robinson Head. For Canadian Built Cars.



A16528ASCAN	28-29	Price Set/4	\$ 4.00
--------------------	--------------	--------------------	----------------

Radiator Splash Apron Screws - Stainless

In 1930-31 the screws passed thru the apron into the mount shield (A16527 or A16528).

4 x 1/4-28 x 1/2 Round head Screws & 4 L/W's.



A16528BS	30-31	Price Set/8	\$ 1.50
-----------------	--------------	--------------------	----------------

Canadian Radiator Splash Apron Screws

Robertson Screws for Canadian Built Cars. Set of 4 Screws Only.



A16528BSCAN	30-31	Price Set/4	\$ 2.85
--------------------	--------------	--------------------	----------------

Radiator Splash Apron Screws

In '30-'31 there is a raised area around the screw hole to accept:

4 1/4-20 x 7/8 Oval Head Screws, L/W's & Nuts.



#24	30-31	Price Set/12	\$ 1.70
------------	--------------	---------------------	----------------

SPLASH APRONS

Mike's "A" FORD-ABLE Parts

Canadian Radiator Splash Apron Screws

Screws for Canadian Built Cars.
Set of 4 Screws Only.



#24CAN 30-31 Price Set/4 \$ 3.75

Radiator Splash Apron Felt Pads

These felt pads can be riveted or glued between the splash apron and radiator shell to eliminate rattles.



The '28-'29's use two while '30-'31's use only one.



A16529AS	28-29	Price Pair	\$	1.25
A16529BS	30-31	Price Ea.	\$	0.75

RUNNING BOARDS AND PARTS

Running Board Bolts

24-piece set of high-crowned bolts, lock washers, and nuts to attach your running boards



A16452

March '28 - March '29

Forged Braces - used 4 5/16-18 x 1 3/16 and 4 5/16-18 x 3/4 Bolts.

Price Set/32 \$ 3.35



A16453

April '29 till end '31

Stamped Steel Braces - used 8 5/16-18 x 3/4 bolts

Price Set/24 \$ 2.75

'30 Running Boards & Splash Apron

For the '30 only, this is a very well made pair of running boards and shields. Shield is spot welded to the board and comes with matting and Stainless Steel trim already in place.



Zinc is also available for Show Cars.

AM204B 1930 Price Pair \$ 265.00

Running Boards

These running boards come with the rubber matting and Stainless trim. Paint the back side and bolt them in place.

1928-29 Ribbed style matting. 1930-31 Pyramid style matting.

Zinc is also available for Show Cars.



AM200B 28-29 Price Pair \$ 185.00

AM207B 1930 Price Pair \$ 185.00

AM201B 1931 Price Pair \$ 265.00

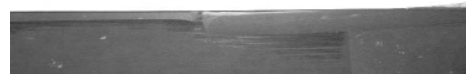

Mike's "A" FORD-ABLE Parts

Commercial Running Boards

Super Quality.
All steel for your **Pickup Truck**.
100 % Authentic.

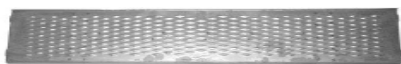

AM202	28-29	Ford Script	Price Pair	\$ 190.00
AM203	30-31		Price Pair	\$ 190.00

Running Board Trim Bolts

This is a set of 10 special oval headed bolts with nuts to attach the inside molding to the '30 running boards. 10 x 12/24" x 19/32" oval head bolts & nuts.



A16454BR	Jan. '30 - Sept. '30	Price Set/30	\$	7.35
----------	----------------------	--------------	----	------

Running Board Rubber Trim

This 1/4" wide, half round rubber goes on the ends and inside edge of the '31 running boards. Set does both boards. Passenger vehicles Only.



A16458BR	1931	Price Roll	\$	9.50
----------	------	------------	----	------

Running Board Trim - Passenger Vehicles

Both zinc and stainless replacement trim is available. Ford used the zinc but it will lose its shine but the polished stainless won't. Enough for both boards.



PLEASE NOTE: This is shipped in a PVC Tube - UPS charges an additional handling fee.

PLEASE NOTE: These cannot be used on original running Boards - made only for reproductions.

A16462A1	28-29	44 1/2" Zinc - 8 Pieces	Price Set	\$ 59.95
A16462ASS	28-29	44 1/2" Stainless - 8 Pieces	Price Set	\$ 59.95
A16462B1	1930	41" Zinc - 8 Pieces	Price Set	\$ 59.95
A16462B2	1930	41" Stainless - 8 Pieces	Price Set	\$ 59.95
A16462C1	1931	41" Zinc - 2 Pieces	Price Set	\$ 45.00
A16462	1931	41" Stainless - 2 Pieces	Price Set	\$ 45.00

1928-29 Running Board Matting

This is the ribbed matting for the '28-'29 boards for you to glue in place. 46" x 9 3/8".



A16450/51RM	28-29	Price Pair	\$	32.95
-------------	-------	------------	----	-------

1930-31 Running Board Matting

This is the pyramid design used on the '30-'31 boards for you to glue in place. 8 7/8" x 11 1/4" x 39 1/4".

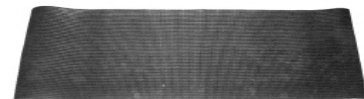

A16450/51PM	30-31	Price Pair	\$	32.95
-------------	-------	------------	----	-------

Running Board Cover Glue

Use this special black contact glue when installing your rubber matting A16450/51RM or A16450/51PM.



A16450CEM	28-31	Price Ea.	\$	16.50
-----------	-------	-----------	----	-------

RUNNING BOARDS

Mike's "A" FORD-ABLE Parts

Running Board Brackets

These pressed steel brackets were originally riveted to the frame but you can also bolt them.



A5125A	28-31	Front right/left	
		Price Ea.	\$ 22.00
A5130A	28-31	Rear left	
		Price Ea.	\$ 22.00
A5130B	28-31	Rear right	
		Price Ea.	\$ 22.00

Running Board Bracket Anti-Squeak Welt

Place this thin 1/16" anti-squeak material on top of each brace before setting on the running boards. **4' Long x 1/16" x 3/4"** woven treated fabric.



A5135	28-31	Price Roll	\$ 2.25
--------------	--------------	-------------------	----------------

Running Board Bracket Mount Kits

This is a complete set of the bolts, nuts, and lock washers to attach your Running Board Brackets. Rounded bolt heads are designed to resemble rivets. **12 x 5/16-18 x 1"** Screws, Lockwashers and nuts.



A5125MB	28-31	Price Set/36	\$ 3.50
----------------	--------------	---------------------	----------------

Running Board Bracket Rivets

If you want it to look like Ford made them, you'll want this complete set of 12 rivets to attach the brackets to the frame.



RA1003	28-31	Price Set/12	\$ 6.75
---------------	--------------	---------------------	----------------

Step Plates

These are really nice **7 3/4 x 8 1/4** polished aluminum step plates with the oval Ford script in the center. Order **#1090** Step Plate Screws & Nuts Separately.



A16400BS	28-31	Price Pair	\$ 39.95
-----------------	--------------	-------------------	-----------------

Step Plate Screws and Nuts

This set of screws and nuts are for mounting the step plate to the board. Will do both plates. **8 Screws & Nuts.**



#1090	28-31	Price Set/16	\$ 1.20
--------------	--------------	---------------------	----------------

Deluxe Step Plates

Beautiful die cast aluminum with black rubber insert. Has small hole in toe plate for mounting emblems (**A16400E**). Emblems sold separately.



NE16400DLX	28-31	Price Pair	\$ 77.00
-------------------	--------------	-------------------	-----------------

Deluxe Step Plate Emblem

Blue cloisonne (glass) with chrome "FORD" Script. Has threaded stud on back for easy attachment to the Deluxe Step Plates (**NE16400DLX**).



A16400E	28-31	Price Pair	\$ 19.25
----------------	--------------	-------------------	-----------------

RUNNING BOARDS

BUMPERS AND PARTS

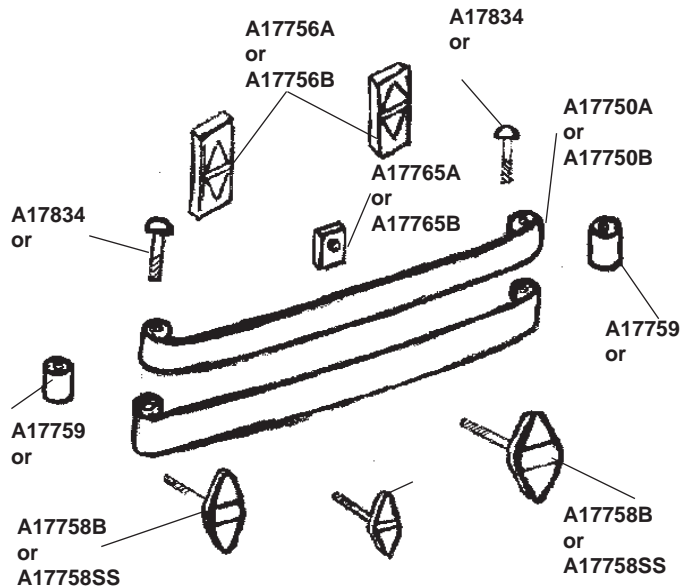

Front Bumper Brackets (Braces) 28-29 Shown

These brackets attach on the front of the frame to hold the front bumpers on. Powder Coated Black. See **Page Gen. 135** for Radiator Mounting Bolts.



A17754/55BRPC	28-29 Ext. length 15 3/4"	Price Pair	\$ 63.50
A17754/55EPC	30-31 Ext. length 14 1/2"	Price Pair	\$ 63.50

Front Bumper Bracket Mounting Bolt Kit

This set has all the nuts, bolts, and washers to attach the front bumper braces to the frame. 4 1/2" - 20 x 1 1/4" with l.w. and nuts. See **A16527** or **A16528** on **Page 205** for '30-'31.



A17754MB	28-29	Price Set/12	\$ 2.95
----------	-------	--------------	---------

1928-1929 Front Bumpers

2 Bars.



A17750A	28-29	Chrome	Price Set/2	\$ 220.00
A17750ASS	28-29	Stainless	Price Set/2	\$ 244.00

1928-1929 Rear Bumpers

4 Bars.



A17814A	28-29	Chrome	Price Set/4	\$ 230.00
A17814ASS	28-29	Stainless	Price Set/4	\$ 254.00

1930-31 Front Bumpers

In **Jan. '30** Ford changed the front bumpers to **62 7/8"** long, these were changed to the **60"** at the end of **August '30** and stayed there until the end of production. 2 Bars.



A17750BE	Jan '30 - Aug '30	Chrome - 62 7/8"	Price Set/2	\$ 215.00
A17750B	Sept. '30 - till end	Chrome - 60"	Price Set/2	\$ 220.00
A17750BSS	30-31	Stainless	Price Set/2	\$ 244.00

1930-31 Rear Bumpers

4 Bars.



A17814B	30-31	Chrome	Price Set/4	\$ 215.00
A17814BSS	30-31	Stainless	Price Set/4	\$ 244.00

Rear Slant Windshield Bumpers

The '31 **Slant-Windshield Fordors** used this bumper with more arch in it. These are chrome plated. 4 Bars.



A17814C	1931	Price Set/4	\$ 215.00
---------	------	-------------	-----------

Spare Wheel Guard Assembly

This stainless steel wheel guard assembly comes with original type mounting bracket and special bolt & nut.



A17806	30-31	Price Set/3	\$ 115.00
--------	-------	-------------	-----------

Mike's "A" FORD-ABLE Parts

Backing Plates

This heavy steel backing plate was used from the beginning until about 3/30.

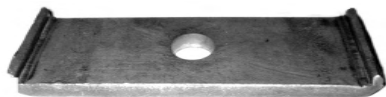

A17756A 28-30 Price Ea. \$ 8.00

Backing Plates

This stamped steel backing plate has a diamond shaped reinforcement stamped into it. For the 3/31 car forward but will work on all cars.

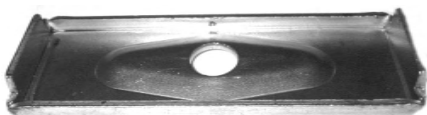

A17756B March 30-31 Price Ea. \$ 2.25

Flag Set

New Design. Spring Loaded Bumper Flag Set. The spring hooks over the bumper. The flag will fit into the holder on the side of the spring.



Great idea if you don't want to take your Backing plates off. One Flag and holder per set.

A18500B 28-29 Price Set \$ 34.50

FOR MORE FLAG SETS - SEE THE ACCESSORIES SECTION ON PAGE GEN. 16

Flag Set

This is a special bracket designed to replace the bumper clamp backing plate so you can show your colors. Set includes 2 flags & 2 Backing Plates.



A17756F 28-31 Price Set/4 \$ 29.95

Bumper Clamps

These are thin, high-quality forged steel clamps like the originals. Order separate decals.



A17758B 28-30 Nuts included Price Ea. \$ 19.50

Bumper Clamps

This style clamp with stainless plating was used from 3/30 forward. Best Made - Show Quality.



A17758SS 30-31 Nuts and decals included Price Ea. \$ 16.50

Canadian Bumper Clamp

Chrome smooth faced clamp. Holds the bumpers to the bumper brackets.



A17758CAN June 28 - August 30 Price Ea. \$ 29.50

Canadian Bumper Clamp

Chrome clamp that used a chrome carriage bolt to hold the bumpers to the bumper brackets.

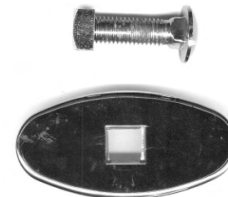

A17758BCAN Aug. 30 - 1931 Price Ea. \$ 16.75

Stainless Bumper Clamp Covers

These stainless clamp covers were used from 3/30 onwards but will work on any original style clamp.



A17758CS 30-31 Price Ea. \$ 5.10

Bumper Clamp Decals

One sheet of this self-adhesive sticker is enough to do 4 large clamps in the original Washington Blue. No messy paint!! Clean the bumper clamps with lacquer thinner before applying decal.

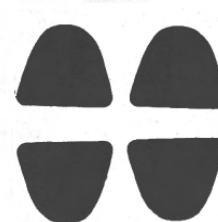

Enough for 4 Clamps.

A17758D 28-31 Price Sheet \$ 3.05

Bumper Clamp Nut Set

This kit has all the nuts and lock washers needed to attach the original four large clamps and small center clamp.

4 Large Nuts and Lock Washer,
1 Small Nut and Lock Washer.



A17758N 28-31 Price Set/10 \$ 1.95

Bumper Spacers (Powder Coated Black)

These rolled style spacers fit between the bumper bars at the ends.



A17759 28-31 Need 2 Pairs Price Pair \$ 1.90

Mike's "A" FORD-ABLE Parts

Stainless Bumper Spacers

Mike also has modern polished stainless bumper spacers. These look very good and will last and last.



A17759SS 28-31 Need 4

Price Ea. \$ 4.00

Rear Bumper Bracket

You will need two of these brackets that hold the inside edge of the '30-'31 rear bumper to the brackets. About 6" long.



A17798 30-31 Price Ea. \$ 18.95

Bumper End Bolts

These cadmium plated bolts, nuts, and lock washers aren't black like the original but they look good. '28-'29 uses 2 pairs, '30-'31 uses 3 pairs. 7/16-20 x 5 1/8" Bolt. Paint Head Black.



A17834 28-31 Price Pair \$ 2.95

Stainless Bumper End Bolts

These stainless steel bolts have a polished head; nuts and lock washers also included. '28-'29 uses 2 pairs, '30-'31 uses 3 pairs. 7/16-20 x 5 1/8" Bolt.



A17834SS 28-31 Price Ea. \$ 4.95

Center Bumper Clamp

This clamp with Ford script was used only until 4/28; complete with nut and lock washer.



A17762A 1928 Price Ea. \$ 7.25

Center Bumper Clamp

From 4/28 to 5/29, this style clamp was used; nut and lock washer included.



A17762B 28-29 Price Ea. \$ 7.25

Center Bumper Clamp

From 11/29 forward, this oval style clamp was used. Nut included. Paint Bumper Clamp blue or order A17762D Decals.



A17762S 29-31 Stainless Price Ea. \$ 6.95

Center Clamp Decal

Instead of painting, use these self-adhesive stickers on the oval center bumper clamp. Clean the bumper clamps with lacquer thinner before applying decal. Enough for 1 Clamp.



A17762D 29-31 Price Ea. \$ 1.10

Center Backing Plate

This is the small backing plate for the center bumper clamp. This style is wider and was used on the 1928-1929's that used the round style center clamp.



A17765A 28-29 Price Ea. \$ 1.40

Center Backing Plate

This small backing plate is for the center bumper clamp.



A17765B 29-31 Price Ea. \$ 1.40

Rear Cross Brace Bolts

These are the correct black oxide bolts with washers and nuts to hold the cross brace on.

4 x 7/16-20 x 1 7/16 Dome Bolts & Lw's.
2 x 7/16-20 x 1 1/32 Hex Bolts & Lw's for end of tubular brace - dome heads face in.



A17787MB 28-29 Price Set/16 \$ 6.50

4 x 7/16-20 x 1 7/16 Domed Bolts, Lw's, and nuts.
A17785MB Jan. 30 - July 30 Price Set/12 \$ 8.25

We no longer stock these - get domed head bolts from your local hardware store.



Regular hex was used from July 1930 till end.

Mike's "A" FORD-ABLE Parts

Rear Cross Brace

This tubular cross brace was used from '28 until early '30.



A17783A 28-30 Price Ea. \$ 44.95

Rear Cross Brace

This pressed steel type cross brace was used in '30-'31.



A17783B 30-31 Price Ea. \$ 28.95

Rear Bumper Extension Brackets

These brackets extend the bumper further away from the rear to allow more room for the luggage rack. Needs a pair of front bumpers. 3 Piece Set



A17777EX 28-31 Price Set/3 \$ 245.00

Rear Bumper Brackets

These brackets extend from the frame to mount the rear bumper. The stands come attached. This bracket is bolted UNDER the top of the frame, approx. 6" in front of the rear crossmember.



A17777A 28-29 Sedan & 28-31 Phaetons 3 1/4" stands Price Pair \$ 150.00

A17777B 30-31 Sedans & Fordor 4 3/4" stands - NOT for Slant Windshields or Victoria's Price Pair \$ 150.00

A17777C 28-31 Coupes & Roadsters 5 1/4" stands Price Pair \$ 150.00

Rear Bumper Bracket to Frame Bolts

This set of nuts, bolts and lock washers has everything you need to install the rear bumper brackets to the frame. The end of the bumper bracket is bolted under the top of the frame, about 6" in front of the rear crossmember.



4 x 3/8 - 24 x 1" - on frame
2 x 7/16 - 20 x 1" - on frame
4 x 5/16 - 18 x 3/4" bolts,l.w.& nuts - on Body Stands
A17779X 28-31 Price Set/30 \$ 5.95

Rear Bumper Bracket Assembly

A17783A - Bumper Cross Brace - 1928-1929

A17783B - Bumper Cross Brace - 1930-1931

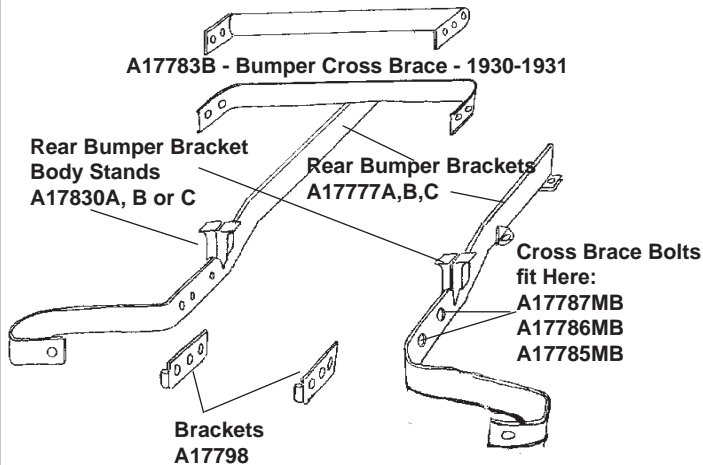

Rear Bumper Bracket-Body Stand

You will need two of these brackets which support the bumper brackets toward the rear of the car.



Note: A17830B is not for Slant Windshields.

A17830C 28-31 Coupes & Roadster - 5 1/4" Price Ea. \$ 14.00

A17830B 30-31 Sedans - Not Slant Windshield or Victoria's - 4 3/4" Price Ea. \$ 14.00



A17830A 28-29 Sedans & 28-31 Phaetons - 3 1/4" Price Ea. \$ 14.00

Rear Bumper Bracket to Stand Rivets

If you need to replace the stands here are the rivets that you will need.



RA1005 Price Ea. \$ 1.00

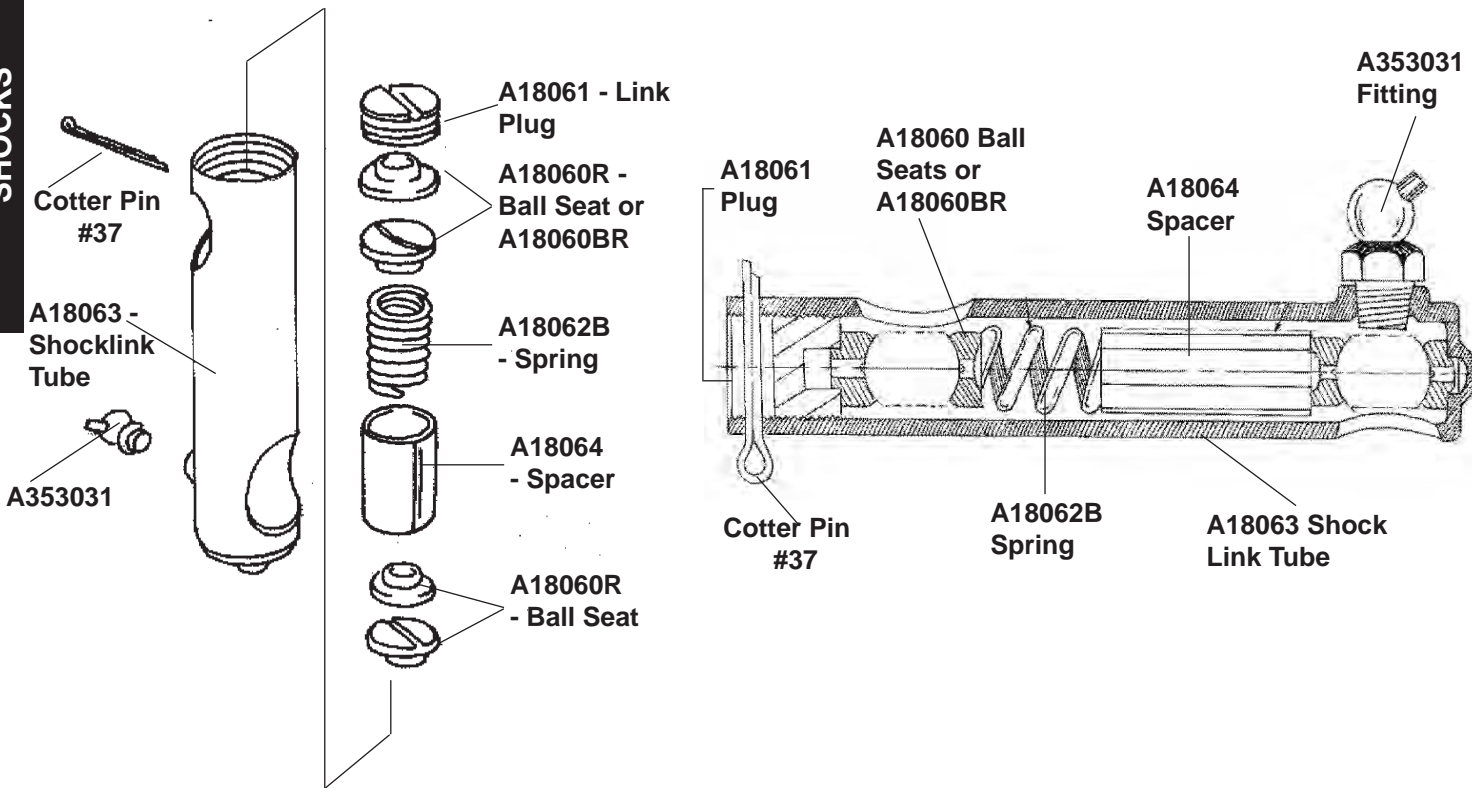

Mike's "A" FORD-ABLE Parts

SHOCKS



Shock Arms

These forged shock arms are good quality.

A18047B	28-31	Front		Price Ea.	\$ 23.00
A18052B	28-31	Rear		Price Ea.	\$ 23.00

Shock Arm Bolts

This set of drilled bolts with castle nuts and cotter pins is what you need to hold all 4 shock arms to the shocks.

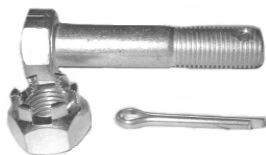

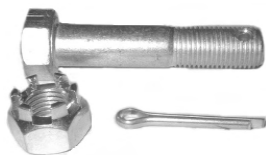
A18047/52MB	28-31	4 x 3/8" - 24 x 1 7/8"		Price Set/12	\$ 5.75
-------------	-------	------------------------	---	--------------	---------

Shock Link

This shock link was used on later Fords, not the A, but it does a good job at a lower price. Comes with rubber bushings installed.



A18055	28-34	Price Ea.	\$ 5.25
--------	-------	-----------	---------

Shock Grease Seal

If you've got the original tube-style links, you'll need this rubber seal to seal the link where the ball enters.



A18058	28-34	Price Set/8	\$ 4.50
--------	-------	-------------	---------

Shock Metal Caps

These protective metal caps cover the A18058 seals.



A18059	28-34	Price Set/8	\$ 6.40
--------	-------	-------------	---------

Shock Link Bushings

This is a set of 8 rubber bushings for the dogbone type shock link.



A18060	28-34	Price Set/8	\$ 4.50
--------	-------	-------------	---------

Shock Link Ball Seat

These brass ball seats ride against the balls on the original tube style links. You will need four per link.



A18060R	28-31	Price Ea.	\$ 0.95
---------	-------	-----------	---------

Shock Link Ball Seat - Teflon

If you're replacing your ball seats, you really should consider these. It is really difficult to grease the original brass seats but you never need to with TEFLON.



This set of 16 seats will refurbish four links.

A18060BR **28-31** **Price Set/16** **\$ 23.25**

Shock Link Plug

This is the plug for the original tubular link. You'll need one per link.



A18061 **28-34** **Price Ea.** **\$ 1.90**

Shock Link Spring

The original tubular shock link used this spring.



A18062B **28-34** **Price Ea.** **\$ 1.00**

Shock Link Spacer

You will need one spacer for each link of the tube type link.



A18064 **28-31** **Price Ea.** **\$ 0.55**

Tubular Shock Link

This is the original style tubular link, complete with all the parts for inside the link.



A18063 **28-31** **Price Set/10** **\$ 17.50**

Shock Seal Set

This kit has all the seals you will need to rebuild all 4 shocks. Includes Info Sheet.



A18096 **28-31** **Price Set/17** **\$ 26.75**



It's All About The Upholstery!

Precision Quality Upholstery for Your Model A.

Ford enthusiasts & restorers worldwide have always sought quick delivery & precision quality in their interior products. So with that in mind, we are proud to distribute the **CARTOUCHE™** brand of precision American made, hand crafted vintage automobile interior products for 1928-1931 Model A Fords, as well as 1909-1927 Model T's & 1932-1951 Early V8 Fords & Mercurys.

The name "Cartouche" refers to the proof-stamp used in days gone by to denote an inspector's acceptance of a quality product. Many military items such as precision rifle stocks & officers' leather saddle bags were stamped by inspectors to certify that the item had passed rigorous quality tests. Since our own inspectors put all of our premium quality interior products through an intensive quality control inspection, we found the name appropriate.

Upholstery Kits

CARTOUCHE™ produces hundreds of upholstery kits every year. All are available in the proper, authentic fabrics. We also offer a wide choice of non-authentic fabrics for the budget-minded hobbyist. All of our complete upholstery kits are produced right here in our modern facility, so you can be sure that all of your items are American made, featuring top-quality materials & workmanship.

Remember, complete Ford upholstery kits are our specialty.

We have been developing & producing these award-winning kits for over 10 years!



Top Kits

CARTOUCHE™ brand top kits are manufactured to original factory specifications, using the most authentic materials available. This includes top material, padding, muslin lining, tacks & trim. Instructions are included with every kit.

With thousands of our premium quality tops already installed on cars all over the world, you can be assured of the fit, appearance & durability you want for your restoration.

Side Curtains, Top Boots, Top Pads, Panel Sets, Carpets & More

If you're looking for top-quality side curtains, purchase **CARTOUCHE™** premium quality units. We make them right here from authentic materials, with long-lasting crystal-clear plastic windows & rust-proof fasteners. We also offer top boots, top pads, rumble panel sets, carpets & a full line of fasteners. We utilize computer operated cutting machines to assure precise cuts. We also use highly skilled sewers to bring you the superior quality, fit & finish you deserve.



Looking Great Inside Vintage Fords For More Than 10 Years!



Your Search for Quality, Fit & Authenticity Ends Here!

ORDERING IS ALWAYS EASY!

We know that you demand the exact pattern, material choices & features of the original upholstery, & we've helped thousands of our customers achieve just that. Replace your old, weathered seats, top or interior to give your car a new appearance! Choose from our large selection of materials to match your taste & budget. Each piece is made to order by our experienced sewers, so you can always expect quality. See the CARTOUCHE™ difference in superior materials, construction & fit.

CARTOUCHE™ Has You Covered From Start To Finish.

Just one call to Mike's & you're done. We offer CARTOUCHE™ brand products for:

- Interior Upholstery Kits
- Top Kits & Top Boots
- Rumble Upholstery Kits
- Carpets
- Side Curtains
- Yard Goods
- Seat Springs
- Rumble Panel Sets
- Supplies, Fasteners & Tools

Satisfaction is the goal with every CARTOUCHE™ product we produce.



Mike's Offers the Exact Features You Want for Your Ford.

Model A Ford Upholstery (1928-1931) Features...

- We are a major producer of all Model A Ford upholstery products from 1928 thru 1931.
- We offer a huge selection of patterns & product lines, with many rare patterns & new items constantly being added.
- We offer complete interior upholstery kits for nearly all Model A's.
- We have an incredible variety of original fabrics & materials to choose from, many that are exclusive to CARTOUCHE™.
- Our top kits are made to the original specifications, using the most authentic materials available.
- We produce precision-made door panels, cowl panels & rumble panels that are available in a wide selection of materials.
- Our seat springs are superior quality & exact copies of the originals.

GET A FREE SAMPLE CARD FOR YOUR VEHICLE WITH ACTUAL SAMPLE MATERIALS (SWATCHES)!

Ford Model A Coupe.....SAMPLE-A1

Ford Model A Tudor, Fordor,
Fordor Town Sedan & Victoria.....SAMPLE-A2

Ford Model A Roadster, Roadster Pickup,
Phaeton, Closed Cab Pickup,
Station Wagon & Cabriolet.....SAMPLE-A3

You can also request a sample card online, simply go to www.mikes-afordable.com





It's All About The Upholstery!

Customers Love To Show Off Their CARTOUCHE™ Interior!

Just take a look at some of our satisfied customers' pictures of their completed & installed interiors. These customers sent us pictures to show the difference a new quality interior from CARTOUCHE™ makes. Send us pictures of your completed car—we'd love to show the end results that CARTOUCHE™ products can make for your car.



Our Customers Say...

Just received my kit from you, thank you. The upholstery is BEAUTIFUL - the seams are straight, there was plenty of selvage & the materials are very high quality. The fit is superb, & the finished installation looks as good as any "professional" job. Once again, thank you for selling a truly quality product. —J. S. from Atlanta, GA

I bought the kit & had it professionally installed locally. Saved me lots of money & looks top notch.

—J. V. from Canyon Lake, CA

I'm very impressed by your selection of fabric material. Also, it is great that you offer technical advice. Obviously, this is more than just a business, it is a passion.

—T. G. from Houston, TX

We received our panel set last night. We are thrilled with the quality & appearance of the work you do!

—D. H. from Horsham, PA

Looking Great Inside Vintage Fords For More Than 10 Years!



Cartouche Has You Covered

We produce hundreds of upholstery kits every year. We offer you a choice of non-authentic fabrics for the budget-minded hobbyist or a full range of authentic interior fabrics for the serious restorer. Either way, we want to ensure your upholstery is as close to the original as possible. Our kits make it easier for you to get what you need.



Sample Upholstery & Hardware Kit



All of our upholstery kits are hand-crafted right, so you can be sure that all of your items are American made & top-quality.

Our full range of authentic interior fabrics are available by the yard for any project you need material for.

We make everything you need to re-upholster your vehicle & we have a complete line of upholstery fasteners. We also carry the tools you'll need to get the job done.

We utilize a computer operated cutting machine to assure precise cuts, & employ only experienced cutters & sewers to bring you a superior product.



Durable



Upholstery Fasteners

Lift-The-Dot



Cinch

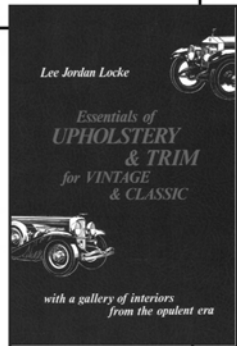

Hog Ring Pliers

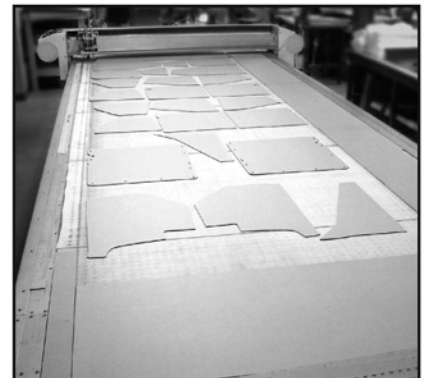



It's All About The Upholstery!

ORDERING IS ALWAYS EASY!

Upholstery Kits

We produce hundreds of **CARTOUCHE™** brand upholstery kits every year. All are available in the proper, authentic fabrics. Keep in mind that we also offer a wide choice of non-authentic fabrics for the budget-minded hobbyist. All of our complete upholstery kits are produced right here in our modern facility, so you can be sure that all of your items are American made, featuring top-quality materials & workmanship. Remember, complete Ford upholstery kits are our specialty. We have been developing & producing these award-winning kits for over 10 years!

MODEL A FORD 28-31 COUPE & CABRIOLET UPHOLSTERY KITS

Coupe & Cabriolet Upholstery Kits & Details

These top-quality kits are complete & include everything necessary to re-upholster the interior of your car. Our kits include: padded & fitted seat covers sewn as original, all interior panels covered & stitched as original, headliner, windlace, padding for springs, installation hardware & instructions. These are quality kits manufactured using authentic or replacement type materials. No leather is used in any of these kits. Because of the large variety of materials & colors, kits are made to order & are not stocked. Please allow 2-4 weeks for delivery.

ITEMS NOT INCLUDED: Floor carpets are not included. Carpets are available.
Always confirm your Model A Ford year & body style before ordering!



1931 Model A Ford Coupe

TO ORDER A CLOSED CAR UPHOLSTERY KIT:

Use the part number that corresponds to your car & put the order combination choice from your Sample Card in the place of the ##### at the end of the part number.

EXAMPLE: 1928 Standard Coupe in order combination UA3X1 Blue Gray Hairline= UCC20329-UA3X1

Model A 28-31 Coupe

Non-Authentic Fabric Combinations

28-29 Standard Coupe.....	UCC20329-#####	569.95 kit
28-29 Sport Coupe (1).....	UCC20729-#####	629.95 kit
28-29 Business Coupe (1).....	UCC20929-#####	569.95 kit
28-29 Special Coupe.....	UCC22429-#####	532.95 kit
30-31 Standard Coupe.....	UCC20431-#####	676.95 kit
30-31 Sport Coupe (1).....	UCC20831-#####	629.95 kit
30-31 Deluxe Coupe.....	UCC22131-#####	759.95 kit

(1) Interior top filler pads are not included, but are listed separately.

Authentic Fabric Combinations

28-29 Standard Coupe.....	UCC20329-#####	730.95 kit
28-29 Sport Coupe (1).....	UCC20729-#####	749.95 kit
28-29 Business Coupe (1).....	UCC20929-#####	730.95 kit
28-29 Special Coupe.....	UCC22429-#####	730.95 kit
30-31 Standard Coupe.....	UCC20431-#####	829.95 kit
30-31 Sport Coupe (1).....	UCC20831-#####	749.95 kit
30-31 Deluxe Coupe.....	UCC22131-#####	958.95 kit

(1) Interior top filler pads are not included, but are listed separately.

Model A 29-31 Cabriolet

Non-Authentic Fabric Combinations

1929 Cabriolet.....	UCC22729-#####	625.95 kit
1930 Cabriolet, stationary seat only.....	UCC227S30-#####	625.95 kit
30-31 Cabriolet.....	UCC22731-#####	625.95 kit

Authentic Fabric Combinations

1929 Cabriolet.....	UCC22729-#####	749.95 kit
1930 Cabriolet, stationary seat only.....	UCC227S30-#####	749.95 kit
30-31 Cabriolet.....	UCC22731-#####	749.95 kit



05 Due To The Size Of These Upholstery Kits, Additional Shipping Charges Will Be Incurred.

Looking Great Inside Vintage Fords For More Than 10 Years!



MODEL A FORD 1928-1931 TUDOR & 1931 VICTORIA UPHOLSTERY KITS

Tudor & Victoria Upholstery Kits & Details

These top-quality kits are complete & include everything necessary to re-upholster the interior of your car. Our kits include: padded fitted seat covers sewn as original, all interior panels covered & stitched as original, headliner, windlace, arm rest covers (when required), padding for springs, installation hardware & instructions. These are quality kits manufactured using authentic or replacement type materials. No leather is used in any of these kits. Because of the large variety of materials & colors, kits are made to order & are not stocked. Please allow 2-4 weeks for delivery.

ITEMS NOT INCLUDED: Floor carpets are not included. Carpets are available.

Always confirm your Model A Ford year & body style before ordering!



1928 Tudor Sedan

OS Due To The Size Of These Upholstery Kits & Panel Sets, Additional Shipping Charges Will Be Incurred.

TO ORDER A CLOSED CAR UPHOLSTERY KIT:

Use the part number that corresponds to your car & put the order combination choice from your Sample Card in the place of the ##### at the end of the part number.

EXAMPLE: 1928 Standard Tudor in order combination UA6X2 Brown Check=UCC20128-UA6X2



Model A Ford 28-31 Tudor

Non-Authentic Fabric Combinations

1928	Standard TudorUCC20128-#####	1111.95 kit
1929	Standard TudorUCC20129-#####	1111.95 kit
30-31	Standard TudorUCC20231-#####	1111.95 kit
30-31	Deluxe TudorUCC202D31-#####	1289.95 kit

Authentic Fabric Combinations

1928	Standard TudorUCC20128-#####	1393.95 kit
1929	Standard TudorUCC20129-#####	1393.95 kit
30-31	Standard TudorUCC20231-#####	1393.95 kit
30-31	Deluxe TudorUCC202D31-#####	1619.95 kit

Model A Ford 31 Victoria

Non-Authentic Fabric Combinations

1931	VictoriaUCC22631-#####	1289.95 kit
------	----------	---------------------	-------------

Authentic Fabric Combinations

1931	VictoriaUCC22631-#####	1619.95 kit
------	----------	---------------------	-------------

Pre-Cut Uncovered Panel Sets

Panel sets for the do-it-yourselfer. These are pre-cut panel sets ready to be covered by you in the material of your choice. Precision cut from our 1/8" water resistant panel board used in all of our kits. Only available for the models listed below.

28-29	NEW Interior panels, Standard & Special Coupe PANEL107	135.95 set
28-29	NEW Interior panels, Tudor Sedan PANEL102	159.95 set
30-31	NEW Interior panels, Standard & Deluxe Coupe (shown) PANEL129	135.95 set
30-31	NEW Interior panels, Tudor Sedan PANEL126	159.95 set
28-29	NEW Rumble panels, Roadster, Coupe, Sport Coupe, Special Coupe, Business Coupe & Cabriolet PANEL100RUM	55.95 set
30-31	NEW Rumble panels, Standard & Deluxe Roadster PANEL122RUM	55.95 set
30-31	NEW Rumble panels, Standard Coupe, Deluxe Coupe, Sport Coupe & Cabriolet PANEL122RUM	55.95 sets



1931 Victoria





It's All About The Upholstery!

MODEL A FORD 1928-1931 FORDOR & TOWN SEDAN WITH BRIGGS BODY ONLY UPHOLSTERY KITS

Fordor Upholstery Kits & Details

These top-quality kits are complete & include everything necessary to re-upholster the interior of your car. Our kits include: padded fitted seat covers sewn as original, all interior panels covered & stitched as original, headliner, windlace, seat riser carpets, side arm rest covers, padding for springs, installation hardware & instructions. These are quality kits manufactured using authentic or replacement type materials. No leather is used in any of these kits. Because of the large variety of materials & colors, kits are made to order & are not stocked. Please allow 2-4 weeks for delivery.

ITEMS NOT INCLUDED: Fordor rear center folding armrest is not included. This must be ordered separately. See bottom of the page. Floor carpets are not included. Carpets are available.

Always confirm your Model A Ford year & body style before ordering!



1929 Briggs Fordor

TO ORDER A CLOSED CAR UPHOLSTERY KIT:

Use the part number that corresponds to your car & put the order combination choice from your Sample Card in the place of the ##### at the end of the part number.

EXAMPLE: 1929 Deluxe Fordor with two windows in order combination UA7X2 Brown Bedford Cord = UCC222B229-UA7X2



Non-Authentic Fabric Combinations

28-29	Std. Fordor Leatherback, Briggs	UCC22829-#####	1135.95 kit
1929	Std. Fordor (2 window), Briggs	UCC205B229-#####	1215.95 kit
30-31	Std. Fordor (2 window), Briggs	UCC205B231-#####	1215.95 kit
1929	Std. Fordor (3 window), Briggs	UCC205B329-#####	1215.95 kit
30-31	Std. Fordor (3 window), Briggs	UCC205B331-#####	1215.95 kit
1931	Std. Slant windshield Fordor & Town Sedan, Briggs & Murray	UCC223S31-#####	1522.95 kit
1929	Dlx. Fordor (2 window), Briggs (2)	UCC222B229-#####	1479.95 kit
30-31	Dlx. Fordor (2 window), Briggs (2)	UCC222B231-#####	1479.95 kit
1929	Dlx. Fordor (3 window), Briggs (2)	UCC222B329-#####	1479.95 kit
30-31	Dlx. Fordor (3 window), Briggs (2)	UCC222B331-#####	1479.95 kit
1929	Dlx. Town Sedan (3 window), Briggs (2)	UCC223B329-#####	1479.95 kit
30-31	Dlx. Town Sedan (3 window), Briggs (2)	UCC223B331-#####	1479.95 kit
1931	Dlx. Slant windshield Fordor & Town Sedan, Briggs & Murray	UCC223A31-#####	1522.95 kit

Authentic Fabric Combinations

28-29	Std. Fordor Leatherback, Briggs	UCC22829-#####	1549.95 kit
1929	Std. Fordor (2 window), Briggs	UCC205B229-#####	1698.95 kit
30-31	Std. Fordor (2 window), Briggs	UCC205B231-#####	1698.95 kit
1929	Std. Fordor (3 window), Briggs	UCC205B329-#####	1698.95 kit
30-31	Std. Fordor (3 window), Briggs	UCC205B331-#####	1698.95 kit
1931	Std. Slant windshield Fordor & Town Sedan, Briggs & Murray	UCC223S31-#####	1999.95 kit
1929	Dlx. Fordor (2 window), Briggs (2)	UCC222B229-#####	1959.95 kit
30-31	Dlx. Fordor (2 window), Briggs (2)	UCC222B231-#####	1959.95 kit
1929	Dlx. Fordor (3 window), Briggs (2)	UCC222B329-#####	1959.95 kit
30-31	Dlx. Fordor (3 window), Briggs (2)	UCC222B331-#####	1959.95 kit
1929	Dlx. Town Sedan (3 window), Briggs (2)	UCC223B329-#####	1959.95 kit
30-31	Dlx. Town Sedan (3 window), Briggs (2)	UCC223B331-#####	1959.95 kit
1931	Dlx. Slant windshield Fordor & Town Sedan, Briggs & Murray	UCC223A31-#####	1999.95 kit

(2) If you have a rear center armrest these are not included. They are available separately at a cost of 70.00. Order part number RCAR.

OS Due To The Size Of These Upholstery Kits, Additional Shipping Charges Will Be Incurred.

Looking Great Inside Vintage Fords For More Than 10 Years!



MODEL A FORD 1928-1931 FORDOR & TOWN SEDAN WITH MURRAY BODY ONLY UPHOLSTERY KITS

Fordor Upholstery Kits & Details

These top-quality kits are complete & include everything necessary to re-upholster the interior of your car. Our kits include: padded fitted seat covers sewn as original, all interior panels covered & stitched as original, headliner, windlace, seat riser carpets, side arm rest covers, padding for springs, installation hardware & instructions. These are quality kits manufactured using authentic or replacement type materials. No leather is used in any of these kits. Because of the large variety of materials & colors, kits are made to order & are not stocked. Please allow 2-4 weeks for delivery.



1930 Murray Fordor

ITEMS NOT INCLUDED: Fordor rear center folding armrest is not included. This must be ordered separately. See bottom of the page.

Floor carpets are not included. Carpets are available.

Always confirm your Model A Ford year & body style before ordering!

TO ORDER A CLOSED CAR UPHOLSTERY KIT:

Use the part number that corresponds to your car & put the order combination choice from your Sample Card in the place of the ##### at the end of the part number.

EXAMPLE: 1929 Deluxe Fordor with two windows in order combination UA7X2 Brown Bedford Cord = UCC222M29-UA7X2



Non-Authentic Fabric Combinations

1929	Std. Fordor (2 window), Murray	UCC205M229-#####	1215.95 kit
30-31	Std. Fordor (2 window), Murray	UCC205M231-#####	1215.95 kit
1929	Std. Fordor (3 window), Murray	UCC205M329-#####	1215.95 kit
30-31	Std. Fordor (3 window), Murray	UCC205M331-#####	1215.95 kit
1929	Dlx. Fordor (2 window), Murray (2) ..	UCC222M229-#####	1416.95 kit
30-31	Dlx. Fordor (2 window), Murray (2) ..	UCC222M231-#####	1479.95 kit
1929	Dlx. Fordor (3 window), Murray (2) ..	UCC222M329-#####	1479.95 kit
30-31	Dlx. Fordor (3 window), Murray (2) ..	UCC222M331-#####	1479.95 kit
1929	Dlx. Town Sedan (3 window), Murray (2) ..	UCC223M329-#####	1479.95 kit
30-31	Dlx. Town Sedan (3 window), Murray (2) ..	UCC223M331-#####	1479.95 kit
1931	Slant windshield Fordor & Town Sedan, Briggs & Murray	UCC223A31-#####	1522.95 kit

Authentic Fabric Combinations

1929	Std. Fordor (2 window), Murray	UCC205M229-#####	1698.95 kit
30-31	Std. Fordor (2 window), Murray	UCC205M231-#####	1698.95 kit
1929	Std. Fordor (3 window), Murray	UCC205M329-#####	1698.95 kit
30-31	Std. Fordor (3 window), Murray	UCC205M331-#####	1698.95 kit
1929	Dlx. Fordor (2 window), Murray (2) ..	UCC222M229-#####	1959.95 kit
30-31	Dlx. Fordor (2 window), Murray (2) ..	UCC222M231-#####	1959.95 kit
1929	Dlx. Fordor (3 window), Murray (2) ..	UCC222M329-#####	1959.95 kit
30-31	Dlx. Fordor (3 window), Murray (2) ..	UCC222M331-#####	1959.95 kit
1929	Dlx. Town Sedan (3 window), Murray (2) ..	UCC223M329-#####	1959.95 kit
30-31	Dlx. Town Sedan (3 window), Murray (2) ..	UCC223M331-#####	1959.95 kit
1931	Slant windshield Fordor & Town Sedan, Briggs & Murray	UCC223A31-#####	1999.95 kit

(2) If you have a rear center armrest these are not included. They are available separately at a cost of 70.00. Order part number RCAR.

05 Due To The Size Of These Upholstery Kits, Additional Shipping Charges Will Be Incurred.

HOW TO TELL A BRIGGS FROM A MURRAY...

The difference between a Briggs & a Murray can be seen in the door windows. The tops of the windows are straight in a Briggs & arched in a Murray.



Briggs: straight top of door window opening



Murray: arched top of door window opening



It's All About The Upholstery!

MODEL A FORD 1928-1931 OPEN CAR, ROADSTER, PHAETON, CLOSED CAB PICKUP & SEDAN DELIVERY UPHOLSTERY KITS

These top-quality kits are complete & include everything necessary to re-upholster the seat springs of your car. Our kits include: fitted seat covers sewn as original, padding for springs, installation hardware & instructions. These are quality kits manufactured using authentic or replacement type materials. No leather is used in any of these kits. Because of the large variety of materials & colors, kits are made to order & are not stocked. Please allow 2-4 weeks for delivery.

ITEMS NOT INCLUDED: Rumble panels, rumble upholstery, cowl & door panel sets & floor carpets are not included. These items are available & are listed separately in this catalog.



1930 Standard Roadster



TO ORDER A OPEN CAR UPHOLSTERY KIT:
Use the part number that corresponds to your car & put the order combination choice from your sample card in the place of the ### at the end of the part number. **EXAMPLE: 1928 Roadster in T10 Black Vinyl = UOC10129-T10**

Non-Authentic Fabric Combinations

28-29 Roadster.....	UOC10129-###	203.95 kit
30-31 Standard Roadster.....	UOC10231-###	265.95 kit
30-31 Deluxe Roadster.....	UOC10331-###	275.95 kit
28-29 Phaeton.....	UOC110FR29-###	399.95 kit
30-31 Standard Phaeton.....	UOC111FR31-###	519.95 kit
1931 Deluxe 2 door Phaeton.....	UOC11331-###	585.95 kit
28-29 Roadster Pickup.....	UOC10429-###	152.95 kit
30-31 Roadster Pickup.....	UOC10531-###	152.95 kit
28-29 Closed Cab Pickup.....	UCC33029-###	159.95 kit
30-M31 Closed Cab Pickup.....	UCC33131-###	159.95 kit
L31 Closed Cab Pickup.....	UCC33131L-###	159.95 kit
29-31 Station Wagon, contains front, jump & rear seats.....	UOC11431-###	465.95 kit
28-31 Sedan Delivery.....	UCC20031-###	213.95 kit

Authentic Fabric Combinations

28-29 Roadster.....	UOC10129-###	239.95 kit
30-31 Standard Roadster.....	UOC10231-###	315.95 kit
30-31 Deluxe Roadster.....	UOC10331-###	325.95 kit
28-29 Phaeton.....	UOC110FR29-###	445.95 kit
30-31 Standard Phaeton.....	UOC111FR31-###	599.95 kit
1931 Deluxe 2 door Phaeton.....	UOC11331-###	669.95 kit
28-29 Roadster Pickup.....	UOC10429-###	192.95 kit
30-31 Roadster Pickup.....	UOC10531-###	192.95 kit
28-29 Closed Cab Pickup.....	UCC33029-###	192.95 kit
30-M31 Closed Cab Pickup.....	UCC33131-###	192.95 kit
L31 Closed Cab Pickup.....	UCC33131L-###	192.95 kit
29-31 Station Wagon, contains front, jump & rear seats.....	UOC11431-###	662.95 kit
28-31 Sedan Delivery.....	UCC20031-###	249.95 kit

Additional yardage of vinyl covered windlace that matches these kits is available.



TYPICAL 1928-1929 ROADSTER

DOOR EDGE PROTECTOR

30-31 **NEW** Tan canvas material, keeps tops of doors from getting scratched, fasteners are included but not installed, Standard & Deluxe Roadsters..... UOC60031 49.95 pair



TYPICAL 1930-1931 ROADSTER

MATERIAL & COLOR CHOICES

Non-Authentic Fabric Combinations

- Type #T10 - Black Vinyl - Fine Smooth Grain
- Type #T12 - Dark Brown Vinyl - Fine Smooth Grain
- Type #T13 - Medium Grey Vinyl - Fine Smooth Grain
- Type #T14 - Saddle Brown Vinyl - Fine Smooth Grain
- Type #T15 - Sandalwood Vinyl - Fine Smooth Grain

Illustrated on the next page!

Authentic Fabric Combinations

- Type #N10 - Brown Crush Grain (28-29 All & April 31-End Deluxe Coupe & 68 Cabriolet)
- Type #A1 - Black/Brown (30-31 Coupe & 68B Cabriolet)
- Type #N8 - Two-Tone Brown (30-31 Deluxe Roadster)

OS Due To The Size Of These Upholstery Kits, Additional Shipping Charges Will Be Incurred.

Looking Great Inside Vintage Fords For More Than 10 Years!



MODEL A FORD 1928-1931 COWL & DOOR PANEL SETS

All panel sets are made from water-resistant panel board that is covered with vinyl & stitched. They are not plain, uncovered cardboard. Installation hardware & illustrated instructions are included. US made & top-quality!

KIT CONTENTS:

Roadster: cowl panels, door panels, hip panels, windlace & fasteners

Phaeton: cowl panels, door panels, extension panels, hip panels, rear quarter panels, windlace & fasteners

Roadster Pickup: cowl panels, door panels, hip panels & fasteners

Deluxe 2 door Phaeton: cowl panels, door panels, quarter panels, windlace & fasteners

Closed Cab Pickup: cowl panels, door panels, door post panels, quarter panels (1928-29 only), door header panels, windshield header panels, windlace & fasteners

Station Wagon: cowl panels, windshield header panel & fasteners

Always confirm your Model A Ford year & body style before ordering!



OS Due To The Size Of The Items On This Page, Additional Shipping Charges Will Be Incurred.

TO ORDER AN OPEN CAR COWL & DOOR PANEL SET :

Use the part number that corresponds to your car & put the order combination choice from your Sample Card in the place of the ### at the end of the part number.

EXAMPLE: 1928 Roadster order combination T10 Black Vinyl = KP5029-T10

Non-Authentic Fabric Combinations

28-29	Roadster	KP5029-###	142.95 set
30-31	Standard Roadster	KP5131-###	145.95 set
30-31	Deluxe Roadster	KP5231-###	224.95 set
28-29	Phaeton	KP6029-###	284.95 set
30-31	Standard Phaeton	KP6131-###	312.95 set
1931	Deluxe 2 door Phaeton	KP7231-###	334.95 set
28-29	Roadster Pickup	KP5329-###	155.95 set
30-31	Roadster Pickup	KP5431-###	152.95 set
28-29	Closed cab pickup	KP7029-###	199.95 set
30-31	Closed cab pickup	KP7131-###	189.95 set
1929	Station Wagon	KP6329-###	40.95 set
30-31	Station Wagon	KP6331-###	40.95 set

Authentic Fabric Combinations

28-29	Roadster	KP5029-###	172.95 set
30-31	Standard Roadster	KP5131-###	189.95 set
30-31	Deluxe Roadster	KP5231-###	279.95 set
28-29	Phaeton	KP6029-###	314.95 set
30-31	Standard Phaeton	KP6131-###	356.95 set
1931	Deluxe 2 door Phaeton	KP7231-###	425.95 set
28-29	Roadster Pickup	KP5329-###	199.95 set
30-31	Roadster Pickup	KP5431-###	195.95 set
28-29	Closed cab pickup	KP7029-###	249.95 set
30-31	Closed cab pickup	KP7131-###	235.95 set
1929	Station Wagon	KP6329-###	49.95 set
30-31	Station Wagon	KP6331-###	49.95 set

Additional yardage of vinyl covered windlace that matches these kits is available.

NON-AUTHENTIC VINYL



T10 - Black



T12 - Dark Brown



T14 - Saddle

AUTHENTIC VINYL



N10- Brown
Crush Grain



A1 - Black/Brown



N8- Two
Tone Brown



T15 - Sandlewood



T13 - Gray

Looking for Non-Authentic or Authentic fabric combinations & combination codes? See the "Material & Color Choices" on the previous page then look at the swatches above!



It's All About The Upholstery!

MODEL A FORD 1928-1931 OPEN CAR TOP ROOF KITS

Roadster, Roadster Pickup & Phaeton Top Roof Kits & Details

All CARTOUCHE™ open car top roof kits include all the fabric parts needed to replace your old top. Everything is cut & stitched to fit the original type top iron & bow assembly. They include the main top deck, rear curtain, rear extensions or gypsy wings, bow covering, front windbreaker, straps, fasteners for the top, welting trim, tips, tacks & complete instructions.



REAR WINDOW INFORMATION: Roadster & Phaeton rear curtains do NOT have a window installed. You must use your old metal framed glass window or purchase a new one. The rear window is installed during installation by the customer. However, 1928-31 Roadster Pickups do have a clear plastic window sewn into the rear curtain.

ITEMS NOT INCLUDED: Top pads, which are necessary, are not included. They must be ordered separately & are listed below. Fasteners, which affix to the body, are not included. They are available as fastener sets or as individual pieces.

OPEN CAR TOP ROOF KIT COLOR CHOICES

Four types of material are available for open car top roof kits. They are illustrated below. Your top material & side curtain material should match.



Colonial Grain



Cobra Short Grain



Tan Canvas



Black Canvas

TAN CANVAS MATERIAL

28-29	Roadster.....	ATRK/1A29-1A	315.95 kit
28-29	Roadster, Shay reproduction model only	ATRK/1A29S-1A	315.95 kit
30-31	Standard Roadster	ATRK/2A31-1A	315.95 kit
30-31	Deluxe Roadster	ATRK/3A31-1A	339.95 kit
28-31	Standard Phaeton	ATRK/8A31-1A	529.95 kit
28-29	Roadster Pickup.....	ATRK/4A29-1A	315.95 kit
30-31	Roadster Pickup.....	ATRK/5A31-1A	315.95 kit
1931	Deluxe 2 door Slant Windshield Phaeton.....	ATRK/10A31-1A	539.95 kit

BLACK CANVAS MATERIAL

28-29	Roadster.....	ATRK/1A29-2A	425.95 kit
28-29	Roadster, Shay reproduction model only	ATRK/1A29S-2A	425.95 kit
30-31	Standard Roadster	ATRK/2A31-2A	425.95 kit
30-31	Deluxe Roadster	ATRK/3A31-2A	449.95 kit
28-31	Standard Phaeton	ATRK/8A31-2A	635.95 kit
28-29	Roadster Pickup.....	ATRK/4A29-2A	385.95 kit
30-31	Roadster Pickup.....	ATRK/5A31-2A	385.95 kit
1931	Deluxe 2 door Slant Windshield Phaeton.....	ATRK/10A31-2A	625.95 kit

COLONIAL GRAIN VINYL MATERIAL

28-29	Roadster.....	ATRK/1B29-3B	240.95 kit
28-29	Roadster, Shay reproduction model only	ATRK/1B29S-3B	240.95 kit
30-31	Standard Roadster	ATRK/2B31-3B	240.95 kit
30-31	Deluxe Roadster	ATRK/3B31-3B	245.95 kit
28-31	Standard Phaeton	ATRK/8B31-3B	370.95 kit
28-29	Roadster Pickup.....	ATRK/4B29-3B	240.95 kit
30-31	Roadster Pickup.....	ATRK/5B31-3B	240.95 kit
1931	Deluxe 2 door Slant Windshield Phaeton.....	ATRK/10B31-3B	439.95 kit

COBRA SHORT GRAIN VINYL MATERIAL

28-29	Roadster.....	ATRK/1B29-4B	240.95 kit
28-29	Roadster, Shay reproduction model only	ATRK/1B29S-4B	240.95 kit
30-31	Standard Roadster	ATRK/2B31-4B	240.95 kit
30-31	Deluxe Roadster	ATRK/3B31-4B	245.95 kit
28-31	Standard Phaeton	ATRK/8B31-4B	370.95 kit
28-29	Roadster Pickup.....	ATRK/4B29-4B	240.95 kit
30-31	Roadster Pickup.....	ATRK/5B31-4B	240.95 kit
1931	Deluxe 2 door Slant Windshield Phaeton.....	ATRK/10B31-4B	439.95 kit

1928-1931 OPEN CAR TOP PADS

(Not included in top roof kits above)

Top pad color should match the top roof kit color & are necessary to install the top roof kits listed above.

28-31	Roadster & Roadster Pickup, black.....	TTPR27	25.95 pair
28-31	Roadster & Roadster Pickup, tan	ATP/RN31	32.95 pair
28-31	Phaeton, black	TPT27	38.95 pair
28-31	Phaeton, tan.....	ATP/TN31	46.95 pair



Looking Great Inside Vintage Fords For More Than 10 Years!



MODEL A FORD 1928-1931 SIDE CURTAIN SETS

SET CONTENTS: All side curtains are neatly bound & all fasteners that affix to the side curtains are included, but not installed. Complete instructions are included. All sets are US made & top-quality!

ITEMS NOT INCLUDED: Fasteners that affix to the body, top iron assembly, windshield & side curtain support rods are not included. They are available as fastener sets or as individual pieces.

WINDOW INFORMATION: All side curtain windows are sewn-in clear vinyl. They are sized & positioned like the originals.



OPEN CAR SIDE CURTAIN SET COLOR CHOICES

Four types of material are available for open car side curtain sets. They are illustrated below. Your top material & side curtain material should match.



Colonial Grain



Cobra Short Grain



Tan Canvas



Black Canvas

TAN CANVAS MATERIAL

28-29 Roadster	A701SCR1A29-1A	415.95 set
28-29 NEW Roadster, Shay reproduction model only	A701SCR1A29S-1A	415.95 set
30-31 Standard Roadster	A701SCR3A31-1A	415.95 set
30-31 Deluxe Roadsters	A701SCR2A31-1A	415.95 set
28-29 Standard Phaeton	A701SCT4A29-1A	579.95 set
30-31 Standard Phaeton	A701SCT5A31-1A	579.95 set
1931 Deluxe 2 door Phaeton	A701SCW10A31-1A	579.95 set
28-29 Roadster Pickup	A701SCP7A29-1A	415.95 set
30-31 Roadster Pickup	A701SCP8A31-1A	415.95 set
1929 Station Wagon	A701SCW9A29-1A	799.95 set
30-31 Station Wagon	A701SCW9A31-1A	799.95 set

BLACK CANVAS MATERIAL

28-29 Roadster	A701SCR1A29-2A	457.95 set
28-29 NEW Roadster, Shay reproduction model only	A701SCR1A29S-2A	457.95 set
30-31 Standard Roadster	A701SCR3A31-2A	457.95 set
30-31 Deluxe Roadster	A701SCR2A31-2A	457.95 set
28-29 Standard Phaeton	A701SCT4A29-2A	659.95 set
30-31 Standard Phaeton	A701SCT5A31-2A	659.95 set
1931 Deluxe 2 door Phaeton	A701SCW10A31-2A	659.95 set
28-29 Roadster Pickup	A701SCP7A29-2A	457.95 set
30-31 Roadster Pickup	A701SCP8A31-2A	457.95 set
1929 Station Wagon	A701SCW9A29-2A	979.95 set
30-31 Station Wagon	A701SCW9A31-2A	979.95 set

COLONIAL GRAIN VINYL MATERIAL

28-29 Roadster	A701SCR1B29-3B	369.95 set
28-29 NEW Roadster, Shay reproduction model only	A701SCR1B29S-3B	369.95 set
30-31 Standard Roadster	A701SCR3B31-3B	369.95 set
30-31 Deluxe Roadster	A701SCR2B31-3B	369.95 set
28-29 Standard Phaeton	A701SCT4B29-3B	525.95 set
30-31 Standard Phaeton	A701SCT5B31-3B	525.95 set
1931 Deluxe 2 door Phaeton	A701SCW10B31-3B	525.95 set
28-29 Roadster Pickup	A701SCP7B29-3B	369.95 set
30-31 Roadster Pickup	A701SCP8B31-3B	369.95 set
1929 Station Wagon	A701SCW9B29-3B	630.95 set
30-31 Station Wagon	A701SCW9B31-3B	630.95 set

COBRA SHORT GRAIN VINYL MATERIAL

28-29 Roadster	A701SCR1B29-4B	369.95 set
28-29 NEW Roadster, Shay reproduction model only	A701SCR1B29S-4B	369.95 set
30-31 Standard Roadster	A701SCR3B31-4B	369.95 set
30-31 Deluxe Roadster	A701SCR2B31-4B	369.95 set
28-29 Standard Phaeton	A701SCT4B29-4B	525.95 set
30-31 Standard Phaeton	A701SCT5B31-4B	525.95 set
1931 Deluxe 2 door Phaeton	A701SCW10B31-4B	525.95 set
28-29 Roadster Pickup	A701SCP7B29-4B	369.95 set
30-31 Roadster Pickup	A701SCP8B31-4B	369.95 set
1929 Station Wagon	A701SCW9B29-4B	630.95 set
30-31 Station Wagon	A701SCW9B31-4B	630.95 set

SIDE CURTAIN STORAGE BAG

28-31	Sized to hold the side curtains without being folded, heavy duty brown vinyl, except 180A Deluxe 2 Door Phaeton	RFP114	35.95
-------	---	--------	-------

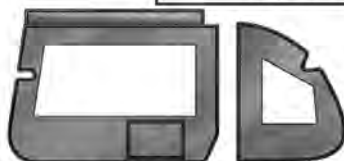

TYPICAL ROADSTER & ROADSTER PICKUP

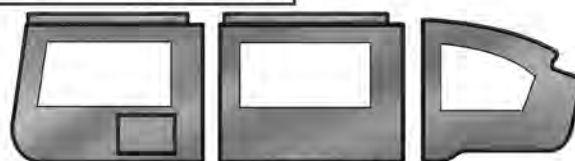

TYPICAL PHAETON



It's All About The Upholstery!

MODEL A FORD 1928-1931 OPEN CAR TOP BOOTS

Top boots will help in keeping dirt & dust from collecting in your top while driving with the roof down. The open car top boot slips over your top irons & top. It is a snug-fitting, dressy cover for the top, when it is folded down. Each boot contains the complete bound & stitched boot & most fasteners that attach to the boot are installed. Fasteners which affix to the body are also included. Straps, however, are not included but are available.



OPEN CAR TOP BOOT MATERIAL CHOICES

Four types of material are available for open car top boots. They are illustrated below. Your top material & side curtain material should match.



Colonial Grain



Cobra Short Grain



Tan Canvas



Black Canvas

TAN CANVAS MATERIAL

28-29 Roadster	ATBR/1A29-1A	179.95
30-31 Deluxe Roadster	ATBR/2A31-1A	179.95
30-31 NEW Standard Roadster	ATBR/3A31-1A	179.95
28-31 Standard Phaeton	ATBT/2A31-1A	240.95
30-31 Deluxe Phaeton	ATBT/3A31-1A	255.95

BLACK CANVAS MATERIAL

28-29 Roadster	ATBR/1A29-2A	232.95
30-31 Deluxe Roadster	ATBR/2A31-2A	232.95
30-31 NEW Standard Roadster	ATBR/3A31-2A	232.95
28-31 Standard Phaeton	ATBT/2A31-2A	298.95
30-31 Deluxe Phaeton	ATBT/3A31-2A	315.95

COLONIAL GRAIN VINYL MATERIAL

28-29 Roadster	ATBR/1B29-3B	150.95
30-31 Deluxe Roadster	ATBR/2B31-3B	150.95
30-31 NEW Standard Roadster	ATBR/3B31-3B	150.95
28-31 Standard Phaeton	ATBT/2B31-3B	199.95
30-31 Deluxe Phaeton	ATBT/3B31-3B	204.95

COBRA SHORT GRAIN VINYL MATERIAL

28-29 Roadster	ATBR/1B29-4B	150.95
30-31 Deluxe Roadster	ATBR/2B31-4B	150.95
30-31 NEW Standard Roadster	ATBR/3B31-4B	150.95
28-31 Standard Phaeton	ATBT/2B31-4B	199.95
30-31 Deluxe Phaeton	ATBT/3B31-4B	240.95

TYPICAL
1928-1929
ROADSTER



TYPICAL
1930-1931
ROADSTER



TYPICAL
1928-1931
PHAETON



STORAGE BAGS

28-31	Top boot storage bag, tan canvas material	FA259	44.00
28-31	Top boot storage bag, black vinyl material	FA257	34.00
28-31	Side curtain storage bag, sized to hold the side curtains without being folded, heavy duty brown vinyl, except 180A Deluxe 2 Door Phaeton	RFP114	35.95

Looking Great Inside Vintage Fords For More Than 10 Years!



MODEL A FORD 1928-1931 RUMBLE UPHOLSTERY KITS

Rumble Upholstery Kits & Details

These top-quality kits are complete & include everything necessary to re-upholster your rumble springs. All upholstery is fitted & stitched. The kit includes sewn fitted seat covers, trim cord, padding, installation hardware & instructions. Cartouche offers 5 non-authentic vinyl colors & 3 authentic vinyl colors. Pick which one is right for you.

Always confirm your Model A Ford year & body style before ordering!

Non-Authentic Vinyl

28-29	Roadster, Coupe, Sport Coupe, Special Coupe, Business Coupe & Cabriolet, non-pleated.....	UOC101RR29-###	119.95 kit
30-31	Standard Roadster, Coupe, Sport Coupe & Cabriolet, 4-1/2" pleats	UOC102RR31-###	153.95 kit
30-31	Deluxe Roadster, Deluxe Coupe & Cabriolet, 2-1/2" pleats	UOC103RR31-###	163.95 kit

Authentic Vinyl

28-29	Roadster, Coupe, Sport Coupe, Special Coupe, Business Coupe & Cabriolet, non-pleated.....	UOC101RR29-###	168.95 kit
30-31	Standard Roadster, Coupe, Sport Coupe & Cabriolet, 4-1/2" pleats	UOC102RR31-###	241.95 kit
30-31	Deluxe Roadster, Deluxe Coupe & Cabriolet, 2-1/2" pleats	UOC103RR31-###	249.95 kit

MODEL A FORD 1928-1931 RUMBLE PANEL SETS

These top-quality panel sets come with complete instructions & consist of 2 side panels, 1 front panel & all installation hardware. All panels are vinyl-covered water-resistant board. Cartouche offers 5 non-authentic vinyl colors & 3 authentic vinyl colors. Pick which one is right for you.

Always confirm your Model A Ford year & body style before ordering!

Non-Authentic Vinyl

28-29	Roadster, Coupe, Sport Coupe, Special Coupe, Business Coupe & Cabriolet.....	KP50RR29-###	104.95 set
30-31	Standard & Deluxe Roadster	KP52RR31-###	104.95 set
30-31	Standard Coupe, Deluxe Coupe, Sport Coupe & Cabriolet	KP52RC31-###	104.95 set

Authentic Vinyl

28-29	Roadster, Coupe, Sport Coupe, Special Coupe, Business Coupe & Cabriolet.....	KP50RR29-###	135.95 set
30-31	Standard & Deluxe Roadster	KP52RR31-###	139.95 set
30-31	Standard Coupe, Deluxe Coupe, Sport Coupe & Cabriolet	KP52RC31-###	139.95 set



TO ORDER A RUMBLE UPHOLSTERY OR PANEL SET:
 Use the part number that corresponds to your car, & put the order combination choice from your sample card in the place of the ### at the end of the part number.
 EXAMPLE: 1929 Coupe Rumble Upholstery Kit in T10 Black= UOC101RR29-T10

NON-AUTHENTIC VINYL



T10 - Black

T12 - Dark Brown

T14 - Saddle



T15 - Sandalwood

T13 - Gray



AUTHENTIC VINYL



N10- Brown Crush Grain

A1 - Black/Brown

N8- Two Tone Brown



It's All About The Upholstery!

MODEL A FORD 1928-1931 CLOSED CAR TOP ROOF KITS

CARTOUCHE™ brand top kits are manufactured to original factory specs, using the most authentic materials available. This includes top material, padding, muslin lining, tacks & sealant. Instructions are included with every kit. With thousands of our premium quality tops already installed on cars all over the world, you can be assured of the fit, appearance & durability you want for your restoration.

ITEMS NOT INCLUDED Fasteners, which affix to the body, are not included. They are available as sets or individual pieces.

KIT CONTENTS:

Closed Cab Pickup: top deck, foam padding, black lining, sealant, welting trim, tacks & complete instructions. Top wood bows were originally painted black & left exposed.

Sport & Business Coupe: top deck, rear curtain, rear apron, bow covering, straps, foam padding, welting, trim, tips, tacks & complete instructions. *The original type rear window & top filler pads are not included.* You must install the rear window into curtain. Use your old metal framed glass window or purchase a new one. The rear window is installed during installation by the customer. Top filler pads are listed below, to the right. The side oval window on business coupes is not included & fabric is not cut. Top wood bows are covered, but still exposed.

Standard & Deluxe Coupe, Fordor, Town Sedans & Tudor: top material, foam padding, sealant, welting trim, tacks & complete instructions. Cobra long grain is the only material choice.

Special Coupe: top deck, rear section, foam padding, sealant, welting trim, tacks & instructions.

Cabriolet: main top deck, rear curtain, rear apron, bow covering, top pads, trim, tacks & complete instructions.

Leatherback: top deck, rear section, foam padding, sealant, welting trim, tacks & instructions.

Station wagon: top deck, foam padding, black lining, sealant, welting trim, tacks & complete instructions. Top wood bows were originally painted black & left exposed.

28-31	Closed Cab Pickup, cobra long grain	ATRK/C15B31	79.95 kit
28-31	Sport Coupe, colonial (1)	ATRK/C3B31-3B	315.95 kit
28-31	Sport Coupe, cobra short grain (1)	ATRK/C3B31-4B	315.95 kit
28-31	Sport Coupe, tan canvas (1)	ATRK/C3A31-1A	345.95 kit
28-31	Sport Coupe, black canvas (1)	ATRK/C3A31-2A	498.95 kit
28-29	Business Coupe, colonial (1)	ATRK/C4B29-3B	295.95 kit
28-29	Business Coupe, cobra short grain (1)	ATRK/C4B29-4B	295.95 kit
28-29	Business Coupe, tan canvas (1)	ATRK/C4A29-1A	343.95 kit
28-29	Business Coupe, black canvas (1)	ATRK/C4A29-2A	498.95 kit
15-31	Coupe, cobra long grain (1)	RCK131	73.95 kit
15-31	Fordor & Town Sedan, cobra long grain	RCK231	94.95 kit
15-31	Tudor, cobra long grain	RCK231	94.95 kit
28-29	Special Coupe, cobra long grain (1)	ATRK/C729	152.95 kit
1929	Cabriolet, tan canvas	ATRK/1229	352.95 kit
29-31	Cabriolet, straight windshield, tan canvas (1)	ATRK/1231	352.95 kit
28-29	Leatherback, black pebble grain	RCK2LB29	179.95 kit
29-31	Station Wagon, cobra long grain	ATRK/1131	130.95 kit

(1) see body identification chart.

CLOSED CAR TOP ROOF KIT COLOR CHOICES

Six types of material are available for closed car top roof kits. They are illustrated below.



Colonial Grain



Cobra Short Grain



Tan Canvas



Black Canvas

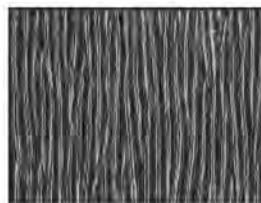

Cobra Long Grain



Black Pebble Grain



1928-1931 CLOSED CAR TOP FILLER PADS

Top filler pads are a necessary part of a Sport or Business Coupe top. The pad color should match the top roof color. These are not included in the roof kits.

28-29	Top filler pad set, black	ATP/CCK29	245.95 set
28-29	Top filler pad set, tan	ATP/CCN29	245.95 set
30-31	Top filler pad set, black	ATP/CCK31	245.95 set
30-31	Top filler pad set, tan	ATP/CCN31	245.95 set

Looking Great Inside Vintage Fords For More Than 10 Years!



MODEL A FORD 1928-1931 CLOSED & OPEN CAR CARPETS

CARTOUCHE™ is proud to offer carpets for Model A Ford closed & open cars from 1928-1931. These are top-quality carpets that you are sure to be pleased with.

All floor carpets are bound & stitched & ready to install. Pedal, transmission & emergency brake positions are cut out as required for each year & body style.

ITEMS NOT INCLUDED: Fastener UF26 attaches to the carpet & the body & is not included. Fasteners are available individually.

IMPORTANT CARPET NOTES: Early 1928 AR vehicles had the emergency brake on the left next to the driver's door. **THIS IS A SPECIAL ORDER:** If you have this type of vehicle you must specifically tell us when you place your order. Mid 1928-Mid 1929 had the emergency brake in front of the floor gearshift. Late 1929-1931 had the emergency brake to the right of the floor gearshift. SEE EMERGENCY BRAKE POSITION IDENTIFICATION ILLUSTRATION AT THE TOP RIGHT OF THIS PAGE.



Early 1928 (special order)



Late 1929-1931



Mid 1928-Mid 1929

TO ORDER A NON-AUTHENTIC FABRIC COMBINATION CARPET:

Use the part number that corresponds to your car, & put the order combination choice from your sample card in the place of the ### at the end of the part number. **EXAMPLE:** 1928 Coupe front carpet in 810 brown= FCC14A29-810

CLOSED CAR CARPET CHOICES

Mike's offers two different materials for your choice of carpets. A high quality Non-Authentic Nylon carpet in 6 different colors & an authentic brown square weave style carpet.

Non-Authentic Fabric Combinations

28-29 Fordor & Town Sedan, front	FCC10B29-###	72.95
28-29 Fordor & Town Sedan, rear	FCC11B29-###	72.95
30-31 Fordor & Town Sedan, front	FCC12B31-###	72.95
30-31 Fordor & Town Sedan, rear	FCC13B31-###	72.95
1931 Fordor/ Slant Window, front	FCC19F31-###	72.95
1931 Fordor/ Slant Window, rear	FCC19R31-###	72.95
28-29 Tudor, front	FCC15A29-###	72.95
28-29 Tudor, rear	FCC16A29-###	72.95
30-31 Tudor, front	FCC15B31-###	72.95
30-31 Tudor, rear	FCC16B31-###	72.95
28-29 Coupe, front	FCC14A29-###	72.95
30-31 Coupe, front	FCC14B31-###	72.95
1931 Victoria, front	FCC17F31-###	72.95
1931 Victoria, rear	FCC17R31-###	93.95
1929 Cabriolet, front	FCC18A29-###	72.95
30-31 Cabriolet, front	FCC1831-###	72.95
1931 Deluxe Roadster, front	FCO2031-###	72.95
1931 Deluxe Phaeton, 2 door, front	FCO21F31-###	72.95
1931 Deluxe Phaeton, 2 door, rear	FCO21R31-###	93.95

Authentic Fabric Combinations

28-29 Fordor & Town Sedan, front	FCC10B29-BRN	139.95
28-29 Fordor & Town Sedan, rear	FCC11B29-BRN	139.95
30-31 Fordor & Town Sedan, front	FCC12B31-BRN	139.95
30-31 Fordor & Town Sedan, rear	FCC13B31-BRN	139.95
1931 Fordor/ Slant Window, front	FCC19F31-BRN	139.95
1931 Fordor/ Slant Window, rear	FCC19R31-BRN	150.95
28-29 Tudor, front	FCC15A29-BRN	139.95
28-29 Tudor, rear	FCC16A29-BRN	139.95
30-31 Tudor, front	FCC15B31-BRN	139.95
30-31 Tudor, rear	FCC16B31-BRN	139.95
28-29 Coupe, front	FCC14A29-BRN	139.95
30-31 Coupe, front	FCC14B31-BRN	139.95
1931 Victoria, front	FCC17F31-BRN	139.95
1931 Victoria, rear	FCC17R31-BRN	207.95
1929 Cabriolet, front	FCC18A29-BRN	139.95
30-31 Cabriolet, front	FCC1831-BRN	139.95
30-31 Deluxe Roadster, front	FCO2031-BRN	139.95
1931 Deluxe Phaeton, 2 door, front	FCO21F31-BRN	139.95
1931 Deluxe Phaeton, 2 door, rear	FCO21R31-BRN	207.95



807 - Dark Gray Nylon



868 - Medium Gray Nylon



897 - Charcoal Nylon



810 - Brown Nylon



840 - Navy Blue Nylon



821 - Taupe Nylon



BRN - Brown (Authentic)



	Recommended Qty	Front	Rear
UF26			
CARPET FASTENER			
30-31 Deluxe Roadster	8	-	-
1931 Deluxe Phaeton	8	12	-
28-31 Coupe	8	-	-
29-31 Cabriolet	8	-	-
28-31 Tudor	8	6	-
28-31 Fordor	8	10	-
30-31 Victoria	8	10	-
ALL Nickel, 2 pieces (A/R)		UF26	1, 15



It's All About The Upholstery!



REAR WINDOW FRAME

This top quality US made rear window frame fits 28-31 Roadster, Phaeton, 30-31 Business Coupe & Cabriolet & includes glass & hardware.

28-31 Stainless steel, 7" x 16-11/16"..... A37639SS 155.00

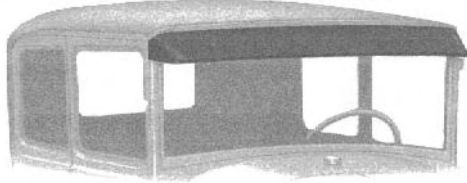

SUN VISOR COVERS

28-29	Sun visor cover, closed car, tan canvas.....	RSV4/1A	26.95
28-29	Sun visor cover, closed car, black canvas.....	RSV4/2A	75.95
28-29	Sun visor cover, closed car, colonial grain.....	RSV4/3B	26.95
28-29	Sun visor cover, closed car, cobra short grain.....	RSV4/4B	26.95
28-29	Sun visor cover, closed car, cobra long grain.....	RSV4/6	26.95
28-29	NEW Sun visor cover, Leatherback, pebble grain.....	RSVP4/P	29.95
28-29	Sun visor cover, reproduction frames, Closed Cab Pickup, cobra long grain.....	RSV3	26.95
28-29	Sun visor cover, original frame, Closed Cab Pickup, cobra long grain.....	RSV5	26.95
30-31	Sun visor to header welt, 4' roll, helps protect wood header from the weather	A3406VW	1.25



Typical Assist Strap

RFP105B RFP105VB RFP105MB

ASSIST STRAPS & HARDWARE

These straps are all new, attached to authentic reproduction brackets, with mounting screws included. They are coachlace braid with napped lining & ribbon-bound edges.

28-31	Assist straps, tan, Tudor & Fordor Sedans, not for Slant Windows	RFP105TAN	74.50 pair
28-31	Assist straps, taupe, Tudor & Fordor Sedans, not for Slant Windows	RFP105TPE	74.50 pair
28-31	Assist straps, grey, Tudor & Fordor Sedans, not for Slant Windows	RFP105GRY	74.50 pair
28-31	Assist straps, green, Tudor & Fordor Sedans, not for Slant Windows	RFP105GRE	74.50 pair
28-31	Assist straps, tan, Slant Window Fordor & Victoria.....	RFP105VTAN	76.00 pair
28-31	Assist straps, taupe, Slant Window Fordor & Victoria	RFP105VTPE	76.00 pair
28-31	Assist straps, grey, Slant Window Fordor & Victoria	RFP105VGRY	76.00 pair
28-31	Assist straps, green, Slant Window Fordor & Victoria	RFP105VGRE	76.00 pair
28-31	Assist strap brackets only, horizontal holes, Tudor & Fordor Sedans.....	RFP105B	8.00 pair
30-31	Assist strap brackets only, vertical holes, Victoria & Slant Window	RFP105VB	8.00 pair



ROBE CORDS

29-31	Robe cords with reproduction brackets, taupe, coachlace braid with a 1/2" nylon cord core, Fordor.....	RFP600HWTPE	101.00
29-31	Robe cords with reproduction brackets, grey, coachlace braid with a 1/2" nylon cord core, Fordor.....	RFP600HWGRY	101.00
29-31	Robe cords with reproduction brackets, green, coachlace braid with a 1/2" nylon cord core, Fordor.....	RFP600HWGRE	101.00
29-31	Robe cord brackets only, chrome plated brass, with mounting screws, not suitable for Slant Windshield Fordor vehicles.....	HW114	11.95 pair



TOP HOLD DOWN STRAPS

30-31	Leather straps for securing the top when it is folded, 21" long, footman loops, hooks & screws included, Standard Roadster, black.....	A42146A	32.60 pair
30-31	Leather straps for securing the top when it is folded, 21" long, footman loops, hooks & screws included, Deluxe Roadster, brown.....	A42146B	32.60 pair

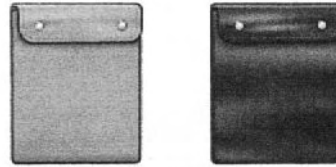

STORAGE BAGS

28-31	Top boot storage bag, tan canvas material.....	FA259	44.00
28-31	Top boot storage bag, black vinyl material.....	FA257	34.00

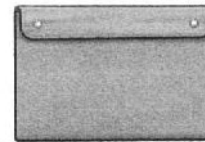

SIDE CURTAIN STORAGE BAG

28-31	Sized to hold the side curtains without being folded, heavy duty brown vinyl, except 180A Deluxe 2 Door Phaeton.....	RFP114	35.95
-------	--	--------	-------

DOOR EDGE PROTECTOR

30-31	NEW Tan canvas material, keeps tops of doors from getting scratched, fasteners are included but not installed, Standard & Deluxe Roadsters.....	A35000	49.95 pair
-------	--	--------	------------

TOP BOW TO TOP IRON FASTENER SET

This set includes all the fastener hardware required to attach the top wood bows to the top irons.

30-31	Deluxe Roadster fastener, 23 piece set.....	UTP3080	11.25 set
-------	---	---------	-----------

TACK RAIL FASTENER SETS

Tack rail fastener sets include all the fastener hardware to attach the open car rear window curtain, rear extensions & gypsy wings to the body.

28-32	Roadster, 11 piece set, cinch fastener style	UTR1000C	32.50 set
28-31	Sport Coupe & Cabriolet, 3 piece set, cinch fastener style.....	UTR2000C	7.40 set
30-31	Roadster Pickup, 36 piece set, cinch fastener style.....	UTR8000C	32.75 set

Looking Great Inside Vintage Fords For More Than 10 Years!

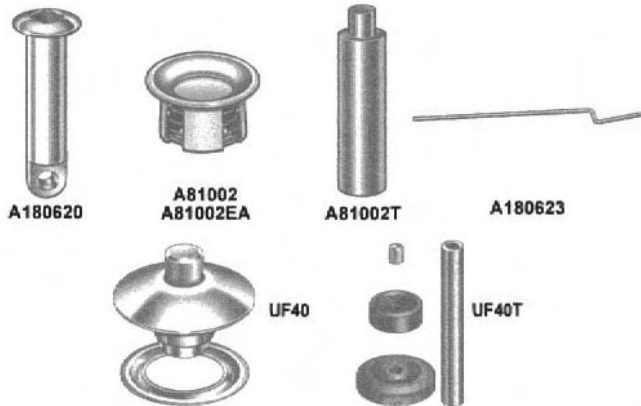

SIDE CURTAIN BODY SOCKETS, RODS & SOCKETS A/R= As Required

The sets listed below include all the body, top iron & windshield fastener hardware required to install open car side curtains. Fasteners that would be part of the side curtains themselves are not included.

30-38	Side curtain rod socke, Deluxe & Phaeton 2-door only, chrome, fits in top of doors (A/R)	A180620	8.45
28-38	Body socket set, 6 sockets	A81002	14.00 set
30-31	Side curtain socket, same as A81002 above, except sold individually	A81002EA	2.36
28-38	Body socket installation tool	T81002	2.00
28-31	Side curtain rods, economy, Standard Roadster, Phaeton & Roadster	A180623	26.95
30-31	Side curtain rods, economy, Deluxe Roadster	A180624	26.95
30-31	Side curtain rods, economy, Deluxe 2-door Phaeton	A180625	57.75 pair
30-31	Side curtain rod support clips, Deluxe Tudor Phaeton	A180621	15.00 pair
28-29	Side curtain rods, original style, Roadster	A41970A	38.00 pair
28-29	Side curtain rods, original style, Phaeton & Pickup	A41970B	38.00 pair
30-31	Side curtain rods, original style, Standard Roadster, Standard Phaeton & Pickup	A41970C	39.00 pair
30-31	NEW Side curtain rods, original style, Deluxe Roadster	A41970D	37.95 pair
ALL	Side curtain fastener with ring, nickel	UF40	7.00
ALL	Tool for installing UF40 side curtain fastener	UF40T	14.50

SIDE CURTAIN FASTENER SETS

These sets include all the body, top iron & windshield fastener hardware required to install open car side curtains.

28-29	Roadster, 28 piece set	USC1000C	40.00 set
28-29	Phaeton, 38 piece set	USC2000L	75.25 set
30-31	Phaeton, 38 piece set	USC7000L	55.00 set
30-31	Deluxe Tudor Phaeton, 51 piece set	USC8000C	70.00 set
30-31	Standard Roadster, 31 piece set	USC5000C	40.00 set
30-31	Deluxe Roadster, 26 piece set	USC6000C	40.00 set
28-29	Roadster Pickup, 34 piece set	USC3000L	45.00 set
30-31	Roadster Pickup, 32 piece set	USC9000L	40.00 set
29-31	Station Wagon, 98 piece set	USC10000C	262.00 set

WINDSHIELD FASTENERS

This contains the male studs that screw into the windshield post for the side curtain & the snaps for the top of the windshield where the top attaches.

28-31	Windshield fastener set, 16 pieces	A37103	20.75 set
28-31	Windshield side curtain snap socket (A/R)	A37170	2.10 each



DURABLE FASTENERS

A/R= As Required

ALL	Durable stud on 3/8" self-tapping screw, nickel (A/R)	UF21	0.75
ALL	Durable stud on #10-32 machine screw, nickel (A/R)	UF22	0.65
ALL	Durable stud on 5/8" self-tapping screw, nickel (A/R)	UF23	1.05
ALL	Durable stud on eyelet, "Gypsy Stud", nickel (A/R)	UF24	0.35
ALL	Carpet fastener, nickel, 2 pieces (A/R)	UF26	1.15

When ordering side curtains or side curtain fasteners sets it is necessary to know which type you have.

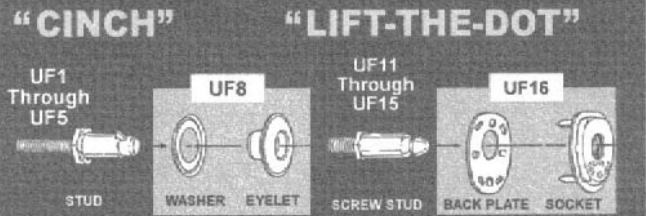

CINCH FASTENERS

A/R= As Required

ALL	Cinch single stud on #10 wood screw, nickel (A/R)	UF1	3.75
ALL	Cinch single stud on #10-32 machine, nickel (A/R)	UF3	2.45
ALL	Cinch double stud on #10-32 machine, nickel (A/R)	UF2	3.00
ALL	Cinch double stud with cinch required mounting, nickel	UF19	2.50
ALL	Cinch double stud on #10 wood screw, nickel (A/R)	UF4	2.45
ALL	Cinch triple stud on #10 wood screw, nickel (A/R)	UF5	2.45
ALL	Cinch eyelet & washer set, nickel (A/R)	UF8	0.55 set

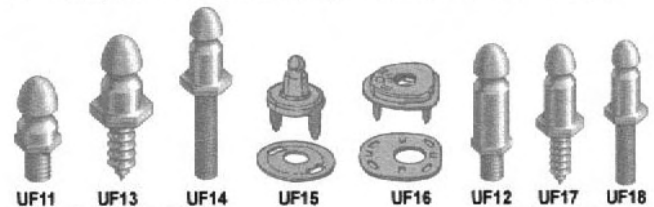

LIFT-THE-DOT FASTENERS

A/R= As Required

ALL	Single stud with #10-32 machine thread, nickel (A/R)	UF11	1.30
ALL	Single stud on 1/2" wood screw, nickel (A/R)	UF13	1.60
ALL	Single stud on 8/32" machine screw, nickel (A/R)	UF14	0.90
ALL	Single stud with cinch type mount, nickel (A/R)	UF15	0.75
ALL	Socket & backing plate for above studs, nickel (A/R)	UF16	1.15
ALL	Double stud on #10-32 machine thread, nickel (A/R)	UF12	1.10
ALL	Double stud on #8 wood screw, nickel (A/R)	UF17	1.10
ALL	Double stud on 8/32" machine thread, nickel (A/R)	UF18	0.75



It's All About The Upholstery!



COMMON SENSE FASTENERS		A/R= As Required
ALL	Turn button, double, 2-screw base, nickel	UF31 1.00
ALL	Turn button, single, 2-screw base, nickel	UF32 0.85
ALL	Single nickel on a #8 wood screw	UF33 1.25
ALL	Double nickel on a #8 wood screw	UF34 1.25
ALL	Turn button, single, bend-over prongs, nickel	UF35 0.80
ALL	Female grommet & washer for above fasteners	UF38 0.40

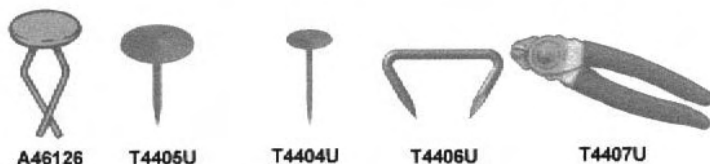

28-31	Door upholstery clip, holds upholstery to door, Coupe, Tudor & Pickup (A/R)	A46126 0.20
09-48	Upholstery tacks, 1/4 lb. box	T4404U 2.00 box
09-48	Large head trim tacks, black, 1/4 lb. box	T4405U 4.85 box
ALL	Hogring set, holds upholstery to springs, approximately 100 pieces	T4406U 2.00 set
ALL	Hogring pliers, installation tool, top quality, spring-loaded	T4407U 24.95

UPHOLSTERY & ROOFING SUPPLIES

Topping materials & Hidem welt are sold by the foot.
Cut goods are NOT returnable for any reason. Please order As Required (A/R)

09-48	Tack strip, hard rubber strip, 1/2" x 3/8", replaces old or missing tack strips, Sold By the Foot	TACKSTRIP 1.00 foot
09-48	NEW Same as above, except 1/8" x 5/8", Sold By the Foot	TACKSTRIP-F 1.00 foot



A36235CF (Closed)



A36235CF (Open)

Hidem welt upholstery trim is a 5/8" wide trim used to fasten top material to wooden frames.

09-48	Black, Sold By the Foot	A47305 0.65 foot
09-48	Brown, Sold By the Foot	A47305T 0.80 foot
09-48	Green, Sold By the Foot	A36235CF/GRN 0.80 foot
09-48	Maroon, Sold By the Foot	A36235CF/MAR 0.80 foot
28-31	NEW N8 black/brown, Sold By the Foot	A36235CF/A1 2.00 foot
28-31	NEW A1 brown crush grain, Sold By the Foot	A36235CF/N10 2.00 foot
28-31	NEW N10 two tone brown, Sold By the Foot	A36235CF/N8 2.00 foot



A36235WF

28-31	"Wire-On" welt, black, Sold By the Foot	A47304 0.90 foot
28-31	"Wire-On" welt, brown, Sold By the Foot	A36235WBRN 3.00 foot
28-31	"Wire-On" welt, N-8 brown, Sold By the Foot	A36235WF-N8 1.95 foot

28-59	Vinyl windlace, for use with our vinyl kits, T10 black, 10'	VWL-T10 15.00 roll
28-59	Vinyl windlace, for use with our vinyl kits, T12 dark brown, 10'	VWL-T12 15.00 roll
28-59	Vinyl windlace, for use with our vinyl kits, T13 gray, 10'	VWL-T13 15.00 roll
28-59	Vinyl windlace, for use with our vinyl kits, T14 saddle, 10'	VWL-T14 15.00 roll
28-59	Vinyl windlace, for use with our vinyl kits, T15 sandalwood, 10'	VWL-T15 15.00 roll
28-59	Vinyl windlace, for use with our vinyl kits, A1 brown crush grain, 10'	VWL-A1 15.00 roll
28-59	Vinyl windlace, for use with our vinyl kits, N8 black/brown, 10'	VWL-N8 15.00 roll
28-59	Vinyl windlace, for use with our vinyl kits, N10 two tone brown, 10'	VWL-N10 15.00 roll



UL



CL

BOOKS

ALL	Essentials Of Upholstery & Trim For Vintage & Classic Cars , for apprentice trimmers, 176 pages, 110 illustrations	UL 14.50
ALL	Antique Auto Body LEATHER WORK For The Restorer , authentic leather upholstery & trimming practice in great detail, 128 pages, 140 illustrations, a good book for anyone doing their own upholstery installation	CL 11.75

Looking Great Inside Vintage Fords For More Than 10 Years!



INTERIOR MATERIALS

Interior materials are sold by the yard. Cut goods are NOT returnable for any reason. Please order As Required (A/R)

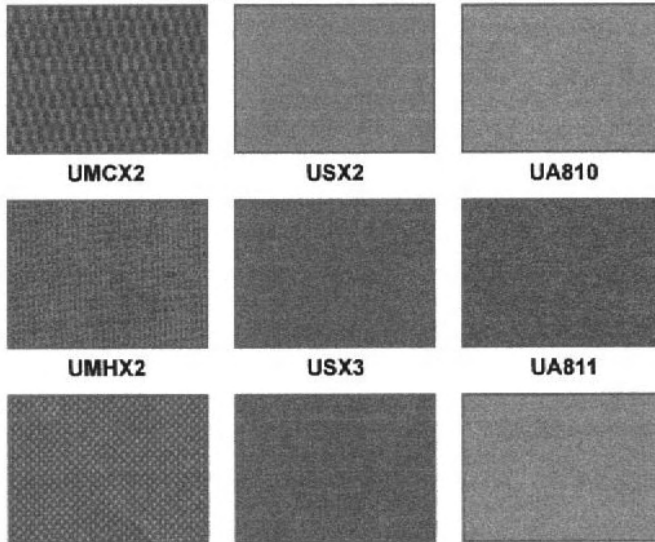

09-48	Brown check, wool, 60" wide, Sold By the Yard	UMCX2	49.95	yard
09-36	Brown plain, wool, 65" wide, Sold By the Yard	USX2	37.95	yard
09-36	Brown headliner, cotton, 54" wide, Sold By the Yard	UA810	15.95	yard
09-48	Blue-gray hairline, wool, 60" wide, Sold By the Yard	UMHX2	49.95	yard
09-48	Dark gray plain, wool, 65" wide, Sold By the Yard	USX3	37.95	yard
09-48	Dark gray headliner, cotton, 54" wide, Sold By the Yard	UA811	15.95	yard
09-48	Small brown check, wool, 60" wide, Sold By the Yard	U15X46	58.95	yard
09-48	Dark brown plain, wool, 60" wide, Sold By the Yard	USX1	37.95	yard
09-48	Brown headliner, cotton, 54" wide, Sold By the Yard	UA810	15.95	yard

TOPPING MATERIALS

Topping materials are sold by the foot or yard. Cut goods are NOT returnable for any reason. Please order As Required (A/R)

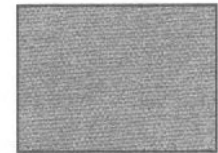
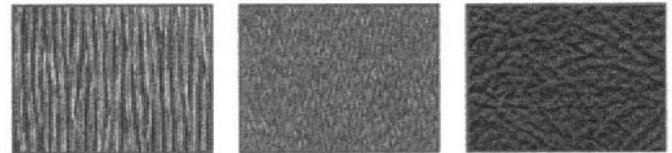

Tan Canvas

09-48	Cobra long grain roof material, 64" wide, closed cars, Sold By the Foot	D255	6.95	foot
09-36	Cobra short grain roof material, 54" wide, open cars, Sold By the Foot	T4409U	5.95	foot
09-36	Colonial roof material, 54" wide, open cars, Sold By the Foot	T4408U	5.95	foot
09-36	Tan canvas topping, cotton, water proof, with UV inhibitor, Sold By the Yard	U0000DKN	37.95	yard

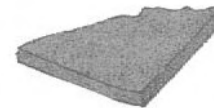

**T44036U
T44038U**

ALL	Black top dressing, gives a new look to your old top, quart can	ATD	17.50	
09-48	Top pad foam 60" x 72" x 1/4", closed cars	T4403U6	9.00	
09-48	Top pad foam 60" x 96" x 1/4", closed cars	T4403U8	12.95	

For Cotton Padding for Coupe Tops - See Page Coupe 33.

For Cotton Padding for Sedan Tops - See Page Sedan 30.



It's All About The Upholstery!

MODEL A BODY STYLE IDENTIFICATION ILLUSTRATIONS



1928-29 STANDARD COUPE (45-A)



1928-29 SPECIAL COUPE (49-A)



1930-31 STD & DLX COUPE (45-B)



1928 BUSINESS COUPE (54-A)



1928-29 SPORT COUPE (50-A)



1930-31 SPORT COUPE (50-B)



1929 CABRIOLET (68-A)



1930-31 CABRIOLET (68-B)



1930-31 VICTORIA (190-A)



1930-31 CONVERTIBLE SEDAN (400-A)



1928-29 TUDOR SEDAN (55-A)



1930-31 TUDOR SEDAN (55-B)



1929 STEELBACK FORDOR (60-C)



1930-31 2-WINDOW FORDOR (60-A,B)



1929-31 3-WINDOW FORDOR (BRIGGS) (155-1B,D/165B,D)



1929-31 3-WINDOW FORDOR (MURRAY) (155-1A,C/165A,C)



1930-31 SLANT WINDSHIELD FORDOR (160-A,B,C)



1928-29 LEATHERBACK FORDOR (60-A,B)



1928-29 STANDARD PHAETON (35-A)



1930-31 STANDARD PHAETON (35-B)



1930-31 DELUXE ROADSTER (40-B)



1928-29 STANDARD ROADSTER (40-A)



1930-31 STANDARD ROADSTER (40-B)



1930-31 DELUXE PHAETON (180-A)



1928-29 OPEN CAB PICKUP (76-A)



1930-31 OPEN CAB PICKUP (76-B)



1928-29 CLOSED CAB PICKUP (82-A)



1930-31 CLOSED CAB PICKUP (82-B)



1928-29 STATION WAGON (150-A)



1930-31 STATION WAGON (150-B)

MODEL A FORDOR BODY STYLE IDENTIFICATION ILLUSTRATIONS



1928-29 (60 A-B) LEATHERBACK 4 DOOR SEDAN



1929-31 (155 - 165 A,B,C,D) 3 WINDOW 4 DOOR SEDAN



1929-31 (170 A-B) 2 WINDOW 4 DOOR SEDAN



1931 (160) SLANT WINDOW 4 DOOR MURRAY SEDAN



1929 (60 C) STEELBACK 4 DOOR SEDAN

Looking Great Inside Vintage Fords For More Than 10 Years!



BODY TYPE IDENTIFICATION CHART

PASSENGER VEHICLES

BODY NAME	1928	1929	1930*	1931
Standard Phaeton	35A	35A	35B	35B
Deluxe Phaeton	--	--	180A	180A
Standard Roadster	40A	40A	40B (Std.)	40B (Std.)
Deluxe Roadster	--	--	40B (Dlx.)	40B (Dlx.)
Standard Coupe	45A	45A	45B (Std.)	45B (Std.)
Deluxe Coupe	--	--	45B (Dlx.)	45B (Dlx.)
Special Coupe	49A	49A	--	--
Sport Coupe	50A	50A	50B	50B
Business Coupe	54A	54A	--	--
Tudor Sedan	55A	55A	55B (Std.)	55B (Std.)
Deluxe Tudor Sedan	--	--	--	--
Leather Back Fordor (Brown)	60A	60A	--	--
Leather Back Fordor (Black)	--	60B	--	--
Steel Back Fordor	--	60C**	--	--
Cabriolet	--	68A	68B	68B
Cabriolet (Slant Window)	--	--	--	68C
Station Wagon	--	150A	150B*	150B
Town Sedan (Murray)	--	155A	155C	155C
Town Sedan (Briggs)	--	155B	155D	155D
Standard Fordor (Slant Window)	--	--	--	160A
Town Sedan (Slant Window)	--	--	--	160B
Deluxe Fordor	--	--	--	160C
Standard Fordor (Murray)	--	165A	165C	165C
Standard Fordor (Briggs)	--	165B	165D	165D
Standard Fordor (2 Windows)	--	170A**	170B (Std.)	--
Deluxe Fordor (2 Windows)	--	--	170B (Dlx.)	170B (Dlx.)
Victoria	--	--	190A	190A
Convertible Sedan	--	--	--	400A

COMMERCIAL VEHICLES

BODY NAME	1928	1929	1930*	1931
Roadster Pickup	76A	76A	76B*	76B
Closed Cab Pickup	82A	82A	82B*	82B
"A" Panel Delivery	79A	79A	79B*	79B
"AA" Panel Delivery (131-1/2")	85A	85A	85B*	85B
Deluxe Delivery (Standard)	130A	130A	130B*	130B
Deluxe Delivery (Drop Floor)	--	--	130B	130B
"AA" Panel Delivery (157")	--	--	--	210A
"A" Panel Delivery (Drop Floor)	--	--	--	225A
Special Delivery	--	--	--	255A
Town Car Delivery	--	--	--	295A
Deluxe Delivery ("AA")	--	--	--	300A

* Change-over from 1929 to 1930 models was in January, 1930 for passenger cars & in June, 1930 for commercial vehicles.

** If you cannot decide if your car body is a 60C or a 170A you can quickly tell by examining the front door post. If it is all steel, it is a 170A. If it has wood parts, it is a 60C.

HOW TO TELL A BRIGGS FROM A MURRAY...

The difference between a Briggs & a Murray can be seen in the door windows. The tops of the windows are straight in a Briggs & arched in a Murray.



Briggs: straight top of door window opening



Murray: arched top of door window opening

MIKE'S "A" FORD-ABLE PARTS

Annual Grandfather's Day Car Show and Barbecue



First Saturday in June



Mike's "A" Ford-able Parts Store, Maysville, GA

Mike's "A" Ford-able Parts is hosting the Grandfather's Day Car Show again for that Grandfather of all cars - the Model A Ford - along with a Barbecue at Mike's Place in Maysville, GA. Starting at 9:30 a.m. We have had over 100 Model A's and over 500 people! We're hoping to make it even **bigger** every year!

There will be a charge for the BBQ lunch consisting of Barbecue, Cole Slaw, Brunswick stew, and iced tea or soda pop - Please call for pricing. A Reservation Form is below. Deadline for reservations for food is 1 week before the event. You must prepay for the meal so we will know how many to prepare for. (*Late Reservations - after the deadline - there is an extra \$1.00 charge per meal*). *Those prepaying for meals will be served first.* Those without prepaid reservations may or may not be served at the above prices, depending upon the amount of food left over. All profits will be donated to our local Model "A" Clubs.

We are looking forward to every Model A owner and his or her family driving or trailering his or her restored or unrestored Model A's (no swap meet or flea market stuff, please) to Mike's. If you want to bring more than one Model A, please do so. There will be no judging, just showing.

We recommend you bring folding chairs to sit in. Also, if you have a light folding picnic table we suggest you bring that too and picnic under the trees. If you are needing to pick up an order - please call it in, in advance - so we can have it ready for you to hopefully eliminate the long wait for parts.

So, please mark your calendar for nothing else on the First Saturday in June Annually, and make plans to celebrate Grandfather's Day at Mike's.

Cut along this line

RESERVATION FORM

Annual Grandfather's Day Car Show & BBQ

First Saturday in June

Deadline for reservations: 1 week before the event.

Mail to: Mike's A Ford-able Parts
124 Model A Drive
Maysville, GA 30558

Choice of Beef BBQ _____ or Pork BBQ _____

Name _____ Phone # _____

I will be driving a Model A: Year _____ Body Style _____ (For more than one Model A please write on the back of this form.)

Please make reservations for: _____ adults 12 years & older - call for current price. \$ _____

And for _____ children under 12 @ - call for current price. \$ _____

My check, payable to "Mike's "A" Ford-able Parts" is enclosed: Total: \$ _____

Please call the office if you would prefer to pay by credit card - 1-706-652-3866

Gen.238 Give us a call - 1-888-TRY-MIKE (879-6453) Have an "A" Day!

The Fine Print - Part 2

Special Orders:

While we carry a large selection of parts, occasionally you will need something that we do not have in stock or normally carry. Please give us a few days and we will try to locate it for you.

PLEASE NOTE: Upholstery, Glass, and Wood Kits are made to order from the manufacturers - these are **NOT REFUNDABLE**.

Missing Items:

We try very hard to make sure that each order is packed properly and that all of your items are sent. First, check your invoice to see if the item has been backordered. If you do find that an item is missing, please check the packing materials in the box. It is easy for a small item to be hidden in the packing. If you are sure that the item was left out by us, please let us know as soon as possible so that we can correct the problem.

Missing items must be reported within 10 days.

Returns & Damaged Items:

We always guarantee your satisfaction. On the rare occasion that you get a defective part, return it **immediately** (unused and in saleable condition) for a full refund. Returned merchandise must be packed carefully as the shipper will be responsible for any damage due to inadequate packing. Credits on returned damaged items will be subject to freight claims settlements. Merchandise that has been tampered with, is rusted or has been drilled, cut, ground or altered in any manner, will **not** be accepted for exchange. Returns on unwanted items or incorrect items will be refunded or exchanged. A 10% restocking fee will be applied to unwanted returned items. Please make sure that your name, reason for the return and a copy of the original invoice is included with the merchandise.

Mike's will not be responsible for any errors on orders when parts numbers are NOT given.

No claims will be accepted after 90 days.

If merchandise was damaged in shipping, please keep the original container and notify Mike's. Mike's will initiate a claim with the couriers, who will then make an appointment with you to inspect the damaged items. Please do not return any damaged items to Mike's until they have been inspected.

Limitation of Liability:

Seller, Manufacturer or Tooling Owner are not liable for any loss, injury, or damage directly arising out of the purchase, installation, or use of any products distributed by Mike's "A" Ford-able Parts. User assumes all risk and liabilities of these products.

Minimum Order: We have **NO** minimum order. We are only too pleased to do business with you.



Next time you are at Mike's why not visit Bentley's!



BENTLEY'S

Bentley's Antique Auto Service, Inc.

(678) 407-1947

www.mymodela.com



Professional Service



Precision Brake Work



Beautiful Restorations

Top Notch Service • Award Winning Restorations • Specializing in Model A Fords

